

T

353

B4

UC-NRLF



5C 16 733

MECHANICAL DRAWING PROBLEMS



BERG & KRONQUIST

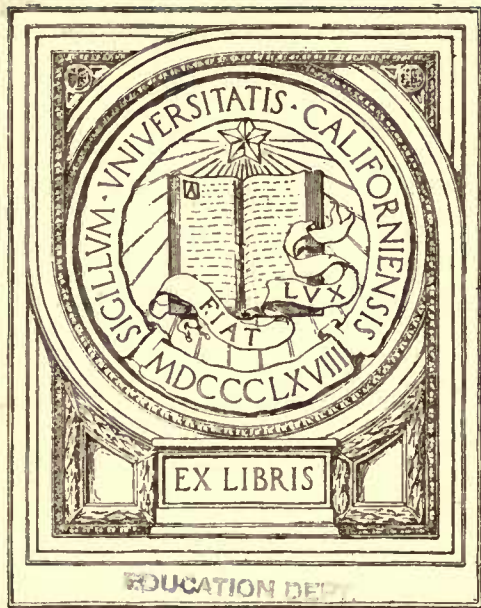

EX LIBRIS

EDUCATION DEPT.





MECHANICAL DRAWING PROBLEMS

FOR

HIGH SCHOOLS, NORMAL SCHOOLS AND VOCATIONAL SCHOOLS

BY EDWARD BERG AND EMIL F. KRONQUIST

Instructions in Mechanical Drawing
Washington High School
Milwaukee, Wis.

UNIV. OF
CALIFORNIA



THE MANUAL ARTS PRESS

PEORIA, ILLINOIS

T 353
B4
Educ.
Dept.

UNIV OF
CALIFORNIA

COPYRIGHT, 1918
EDWARD BERG AND EMIL F. KRONQUIST
EDUCATION DEPT.

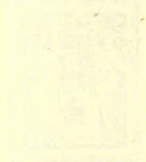

THE MANDARIN PRESS
Peking China

PREFACE

The aim of the authors is to present to the student and the teacher a collection of progressive problems embodying the fundamental principles and examples of practical mechanical drawing, arranged to cover two years of school work. The problems are grouped into first semester, second semester, and third and fourth semester work, and arranged with the view in mind of teaching the proper amount of principles and application during a given period of time. With this plan it is felt that the student who leaves school at any time during the first two years or at the end of two years, will have received the proportional amount of mechanical drawing which will serve his needs best in the practical walks of life.

Each problem is given in the form of a specification sheet and a lay-out sheet from which the student is to make the completed drawing. The specification sheet gives a statement of the problem and is frequently supplemented with text matter which bears upon and emphasizes the thing to be taught in the problem, or gives some relative information. The lay-out sheet suggests the method of procedure, and also furnishes an object lesson in the form of carefully executed work which is always before the pupil. With this method, class instruction is reduced to a minimum, giving the teacher more time for individual instruction, and the pupil the opportunity of working things out by himself. The proper use of the specification, lay-out, and reference sheets will do much, it is believed, towards creating self-reliance and personal effort and exertion on the part of the student.

The required problems are fully supplemented, making the course flexible, and suitable for many needs. The reference sheets are made use of thruout the book, and will be found a valuable feature. The extra plates may be used to extend the work over a period of more than two years.

OUTLINE OF COURSE BY SEMESTERS.

FIRST SEMESTER

REQUIRED PROBLEMS			SUPPLEMENTARY PROBLEMS		
No.	TITLE	PAGE	No.	TITLE	PAGE
1	Instrumental Exercise	14			
2	Lettering	18			
3	Geometric Problems	22			
4	Lap Joint	26			
5	T-Slot Base	30			
6	V-Block	32			
7	Bracket	34	7A	Brace	36
8	Ink-Well Stand	38	8A	Try-Square	40
9	Nail Box	42	9A	Bench-Hook	44
10	Mortise-and-Tenon Joint	46	10A	Dovetail Joint	48
11	Ring	50	11A	Strap	52
12	Face-Plate	54	12A	Valve Stem	56
13	Clutch Thimble	58	13A	Shaft Bracket	60
14	Pen Tray	62	14A	Pin Bearing	64
15	Book-Rack	66	15A	Footstool	68

Plates 1, 2, 3, 8, 12, and 15 are required inked or traced. As many other plates as the time will permit should be inked or traced. If possible, a blueprint should be made from tracing of plate 15.

The supplementary problems are intended for the student that works ahead of the class. They may be substituted for the corresponding required problems or be given as additional problems. They may also be used as test plates.

SECOND SEMESTER

REQUIRED PROBLEMS			SUPPLEMENTARY PROBLEMS		
No.	TITLE	PAGE	No.	TITLE	PAGE
16	Lettering	70			
17	Triangular Prism	74			
18	Hexagonal Prism	76			
19	Octagonal Prism	78			
20	Triangular Pyramid	80			
21	Square Prism (inclined).....	82			
22	Triangular Prism (inclined).....	84			
23	Hexagonal Pyramid (inclined).....	86			
24	H-Block (revolved)	88			
25	Notched Block (inclined and revolved)	90			
26	Truncated Pyramid	92	26A	Truncated Prism	94
27	Tool-Post Slide	96	27A	Hexagonal Wrench	98
28	Frame	100	28A	Nut Bowl	102
29	Gland	104	29A	Gear Blank	106
30	Pipe Elbow	108	30A	Chain	110
31	Babbitt Bearing.....	112	31A	Flanged Bushing	114
32	Rocker Arm	116	32A	Bell Crank Lever.....	118

Plates 16, 27, 28, 29, 30, 31, and 32 are required inked or traced. As many other plates as the time will permit should be inked or traced. If possible, a blueprint should be made from tracing of plate 32.

The supplementary problems are intended for the student that works ahead of the class. They may be substituted for the corresponding required problems or be given as additional problems. They may also be used as test plates.

THIRD AND FOURTH SEMESTERS

REQUIRED PROBLEMS			SUPPLEMENTARY PROBLEMS		
No.	TITLE	PAGE	No.	TITLE	PAGE
33	Truncated Square Prism.....	120	33A	Truncated Square Prism.....	122
34	Truncated Octagonal Prism.....	124	34A	Truncated Pentagonal Prism.....	126
35	Truncated Triangular Prism.....	128	35A	Truncated Triangular Prism.....	130
36	Truncated Triangular Pyramid.....	132	37A	Truncated Oblique Pyramid.....	136
37	Truncated Square Pyramid.....	134	38A	Sheet-Metal Hood.....	140
38	Truncated Cylinder.....	138	39A	Oblique Cone.....	144
39	Truncated Cone.....	142	40A	Intersecting Cylinder (60°).....	148
40	Intersecting Cylinders (90°).....	146	41A	Cylinder Intersecting Cone (60°)...	152
41	Cylinder Intersecting Cone (90°)....	150	42A	Reducing Tee.....	156
42	Ventilator.....	154	43A	15° Fork Wrench.....	160
43	Pipe Elbow and Funnel.....	158	44A	Slotted Segment.....	164
44	Steering Column Support.....	162	45A	Hand Wheel.....	168
45	Cast Iron Pulley.....	166	46A	Bed.....	172
46	Library Table.....	170	47A	Isometric Drawings.....	176
47	Isometric Drawings.....	174	48A	Machine Bolts.....	180
48	U. S. Standard Thread.....	178	49A	Architectural Details.....	186
49	Automobile Garage.....	182			

Plates 42 to 49 inclusive, should be inked or traced. If possible, blueprints should be made from tracings of plates 45 and 49.

The supplementary problems are intended for the student that works ahead of the class. They may be substituted for the corresponding required problems or be given as additional problems. They may also be used as test plates.

REFERENCE SHEETS

TITLE	PAGE	TITLE	PAGE
Geometric Problems	188	U. S. Standard Bolts and Nuts.....	198
How to Sharpen a Pencil.....	192	U. S. Standard Thread	199
Inking Irregular Curves	193	Square Thread and Acme Thread.....	200
Dimensioning	194	Various Kinds of Screws.....	201
Methods of Indicating Finish.....	195	Cabinet Drawing Illustrated.....	202
Representation of Materials.....	196	Architectural Details	203
Conventional Sections	197		

EXTRA PLATES

TITLE	PAGE	TITLE	PAGE
Structural Steel Forms.....	204	Library Table	212
Paper Punch	205	Library Table	213
Metalworking Vise	206	Turned Pedestal	214
Vise Details	207	Candlesticks	215
Hammered Copper Lamp.....	208	Square Pedestal	216
Fern Stand	209	Automobile Garage	217
Costumer	210	Window Details	218
Piano Bench	211	Summer Cottage	219-223

PROBLEMS AND SPECIFICATIONS

LIST OF INSTRUMENTS AND MATERIALS.

1. Set of drawing instruments, including at least one ruling pen and a compass with interchangeable lead point and pen point.
2. Drawing board.
3. T-square.
4. 45° and 30° — 60° triangles.
5. Irregular curve.
6. 12-inch architect's triangular scale.
7. One 6H and one 3H pencil.
8. Bottle of drawing ink.
9. 1 doz. flat head thumb-tacks.
10. Penholder, assorted writing pens.
11. Pencil eraser and cleaning rubber.
12. Piece of soft cloth to keep ruling pen clean, and a few small sheets of sandpaper to keep pencil points sharp.

The drawings are made on 11" x 15" sheets of paper which are cut from the "Imperial" size sheet which is a standard size and measures 22" x 30". They are trimmed to 10" x 14½" when the drawing is completed. A good grade of cream colored or white paper is recommended.

LAY-OUT SHEET

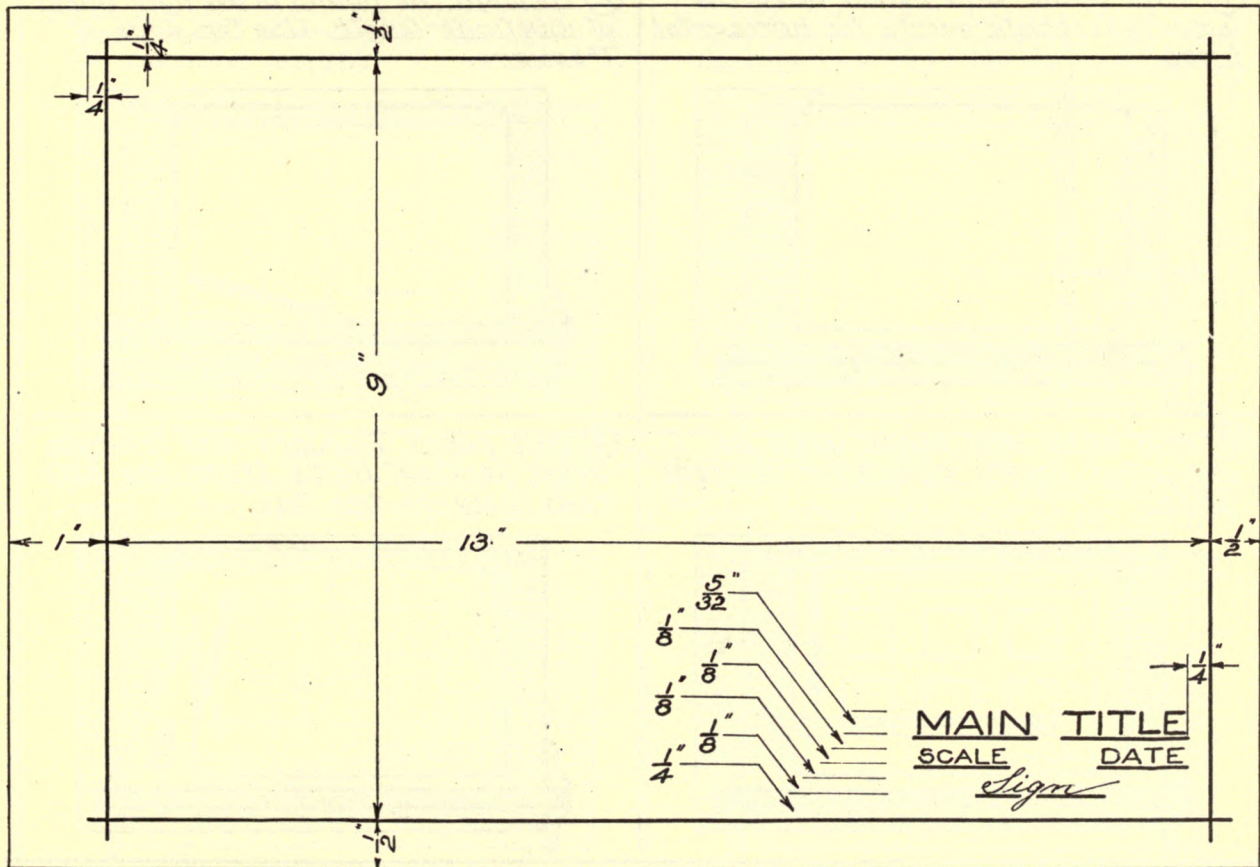

METHOD OF LAYING OUT BORDER LINE AND CUTTING LINE

① *With scale and pencil used as indicated, locate points for horizontal lines.*

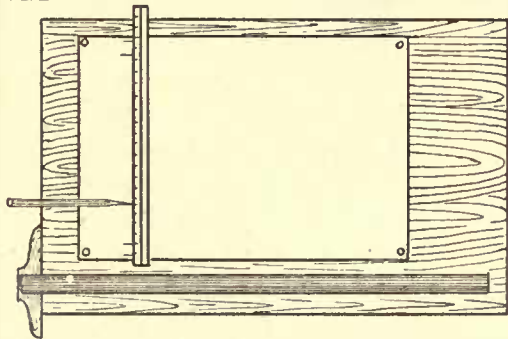

② *Through the points draw light lines of indefinite length. Use top edge of T-square.*

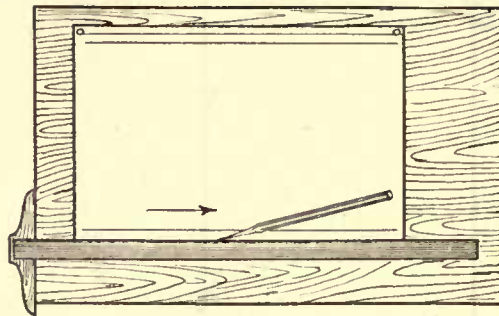

③ *With scale and pencil used as indicated, locate points for vertical lines.*

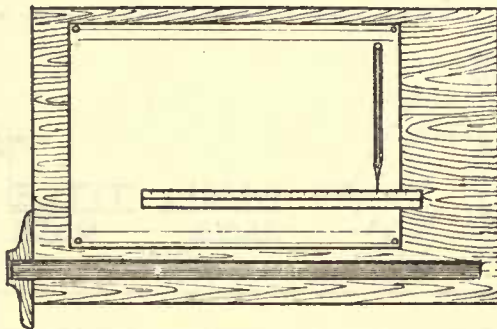

④ *With pencil, T-square and triangle draw vertical lines from the bottom towards the top.*

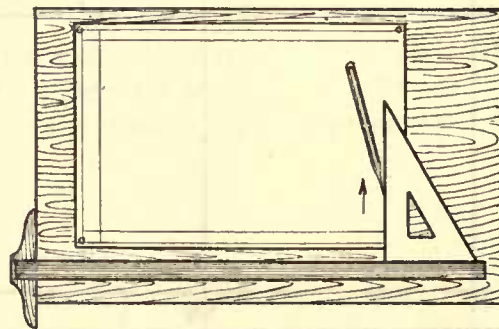

⑤ *Draw very light circular arcs as indicated, cutting off border line to desired length.*

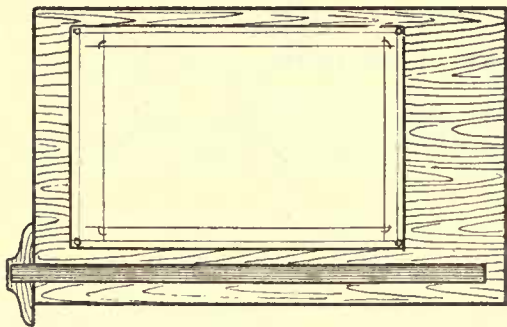

⑥ *The finished border line as it will look when "penciled in". The cutting line need not be penciled in.*

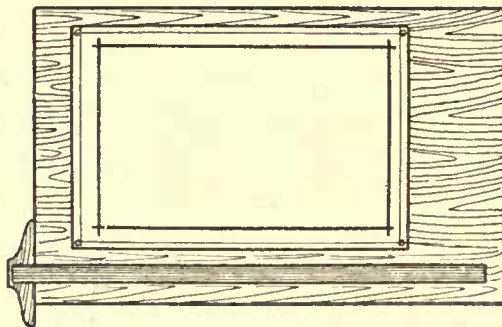

METHOD OF LAYING OUT A SIMPLE PLATE.

① *Pencil lay-out of a simple plate ready to be "penciled in," or inked.*

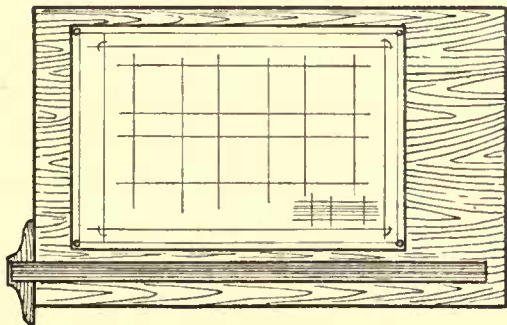

② *The finished plate as it will appear when penciled in or inked.*

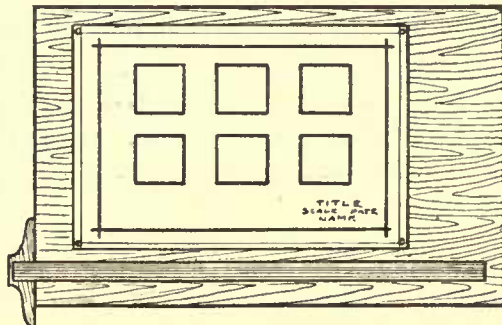

Specification—Plate 1.

Draw horizontal and vertical lines with T-square and triangle to form eight squares as shown in the lay-out sheet on the opposite page.

Draw diagonals in squares 1, 2, 3, 4, 5, 6, and space off half inches on the diagonals.

Sq. 1. Draw horizontal and vertical lines through half inch marks.

Sq. 2. " 45° lines (to a horizontal) through half inch marks in both directions.

Sq. 3. " 30° " " " " " " " " " " " "

Sq. 4. " 60° " " " " " " " " " " " "

Sq. 5. " 15° " " " " " " " " " " " "

Sq. 6. " 75° " " " " " " " " " " " "

Sq. 7. " five concentric circles.

Sq. 8. " three eccentric circles 2½", 1¾" and 1" in diameter.

Draw four lines used in mechanical drawing; visible, invisible, projection and center lines.

Draw three arcs having 9, 8, and 7 inch radii.

Omit all dimensions and figures.

1. What is an angle?
2. How many degrees are there in a circle?
3. How many degrees are there in a right angle?
4. What is meant by concentric and eccentric circles?

PLATE 1

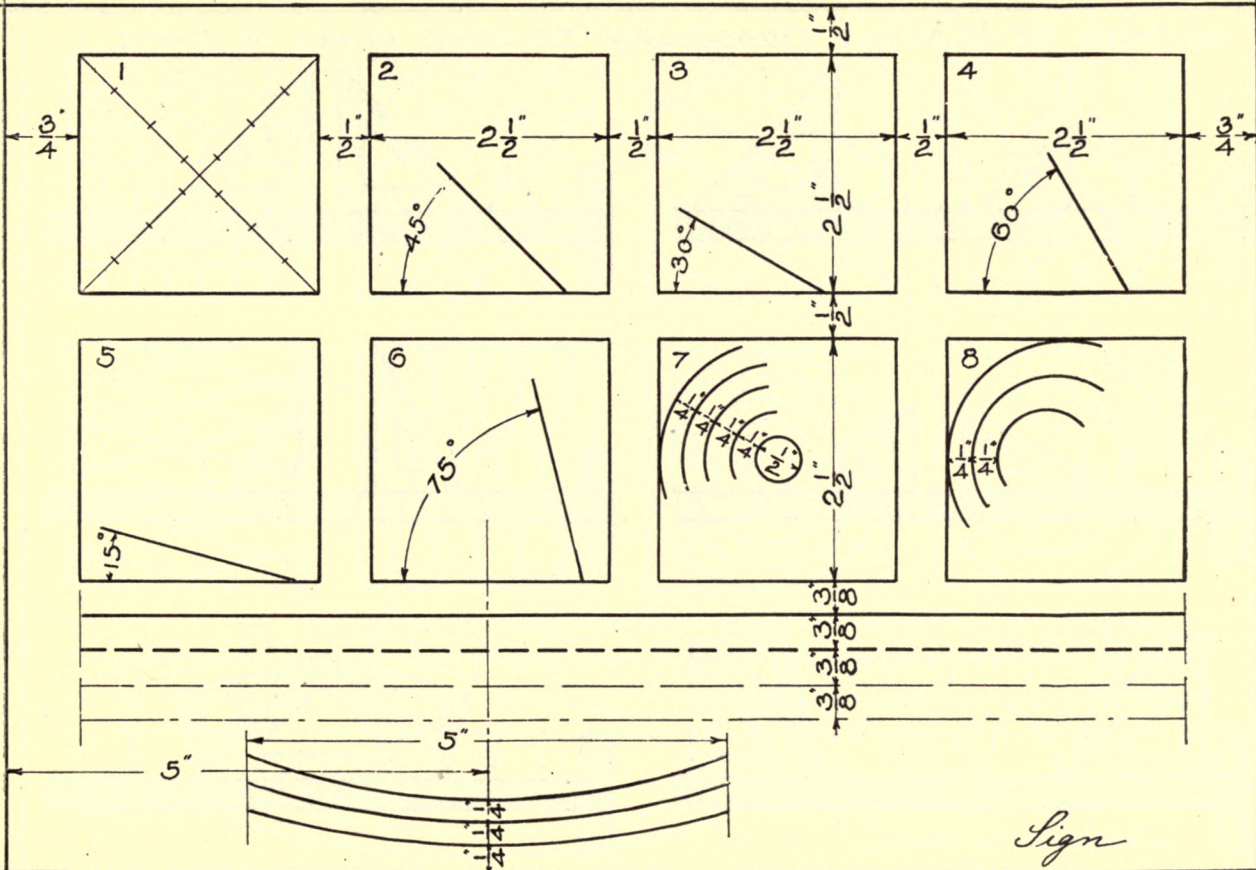

Sign

METHOD OF PLACING TRIANGLES TO DRAW LINES IN PLATE 1

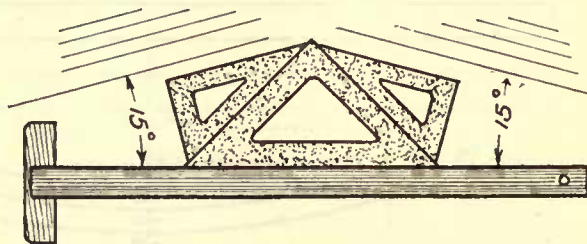
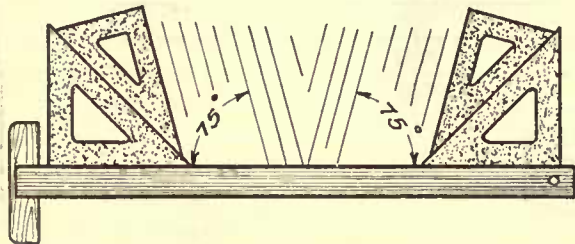
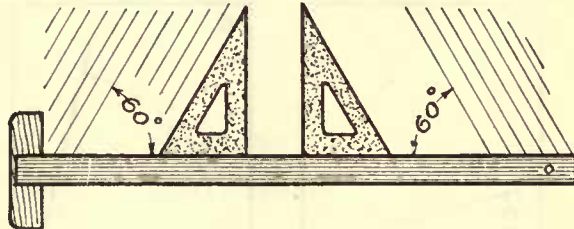
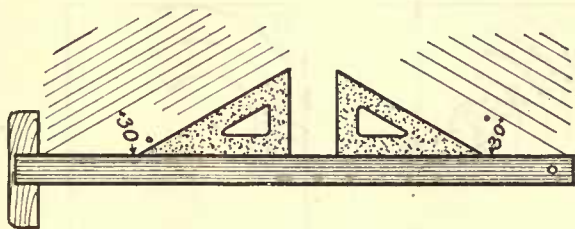
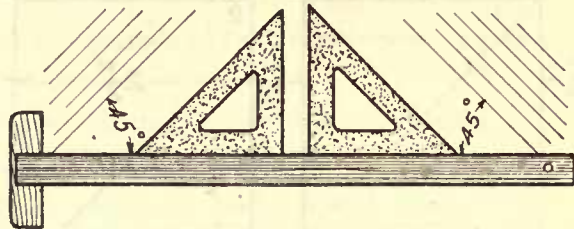
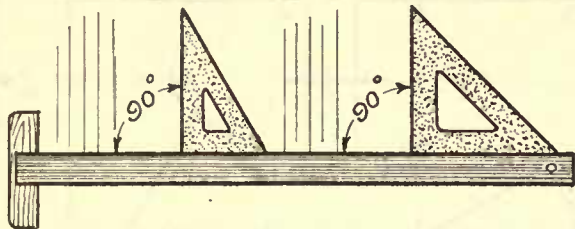
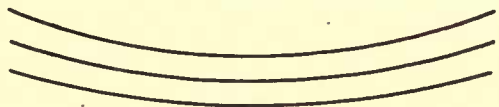
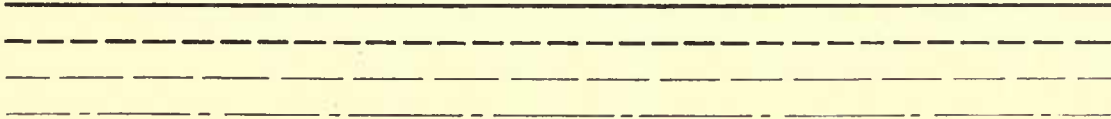
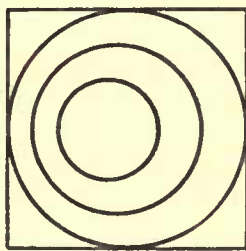
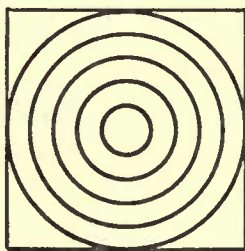
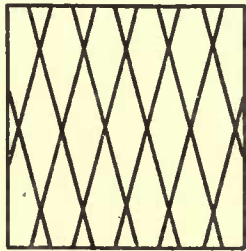
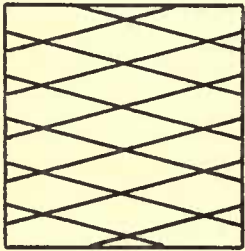
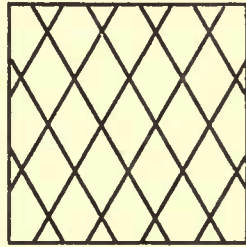
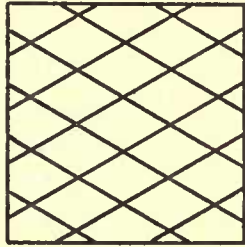
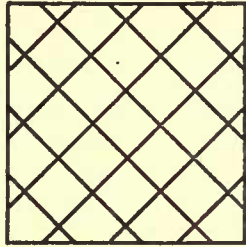
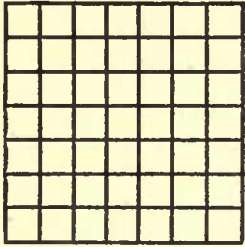

PLATE 1 (Completed)



Robert Watson

Specification—Plate 2.

This plate is to acquaint the student with the form and method of executing upright gothic capital letters and to lay the foundation for the lettering on the plates that are to follow.

The letters are arranged in three groups: the first group comprising those of vertical and horizontal strokes; the second group including slant or inclined strokes; the third group including curved strokes. A number of words are given with each group. Enough words should be lettered to fill out the space. Shorter words such as IF, IT, TILL, WE, AXE, and IN, may be used or original words may be substituted by the student.

In laying out the sheet draw first the horizontal guide lines. The bow dividers may be set to the height of the letters and used to good advantage. Then draw the vertical guide lines for the letters in the groups, spacing them evenly as indicated in the lay-out sheet. *The letters in the words should be close to each other and the words well separated.* Draw a few vertical guide lines, spacing them at random, to help form the letters in the words and also the figures. The direction of each stroke should be followed carefully and should always be used in making the letters.

The title should always be symmetrical with reference to a vertical center line and should be located as indicated on the lay-out sheet. Start with the longest line and letter backwards. This will insure its being placed correctly and will help in making it symmetrical.

LAY-OUT OF PLATE 2

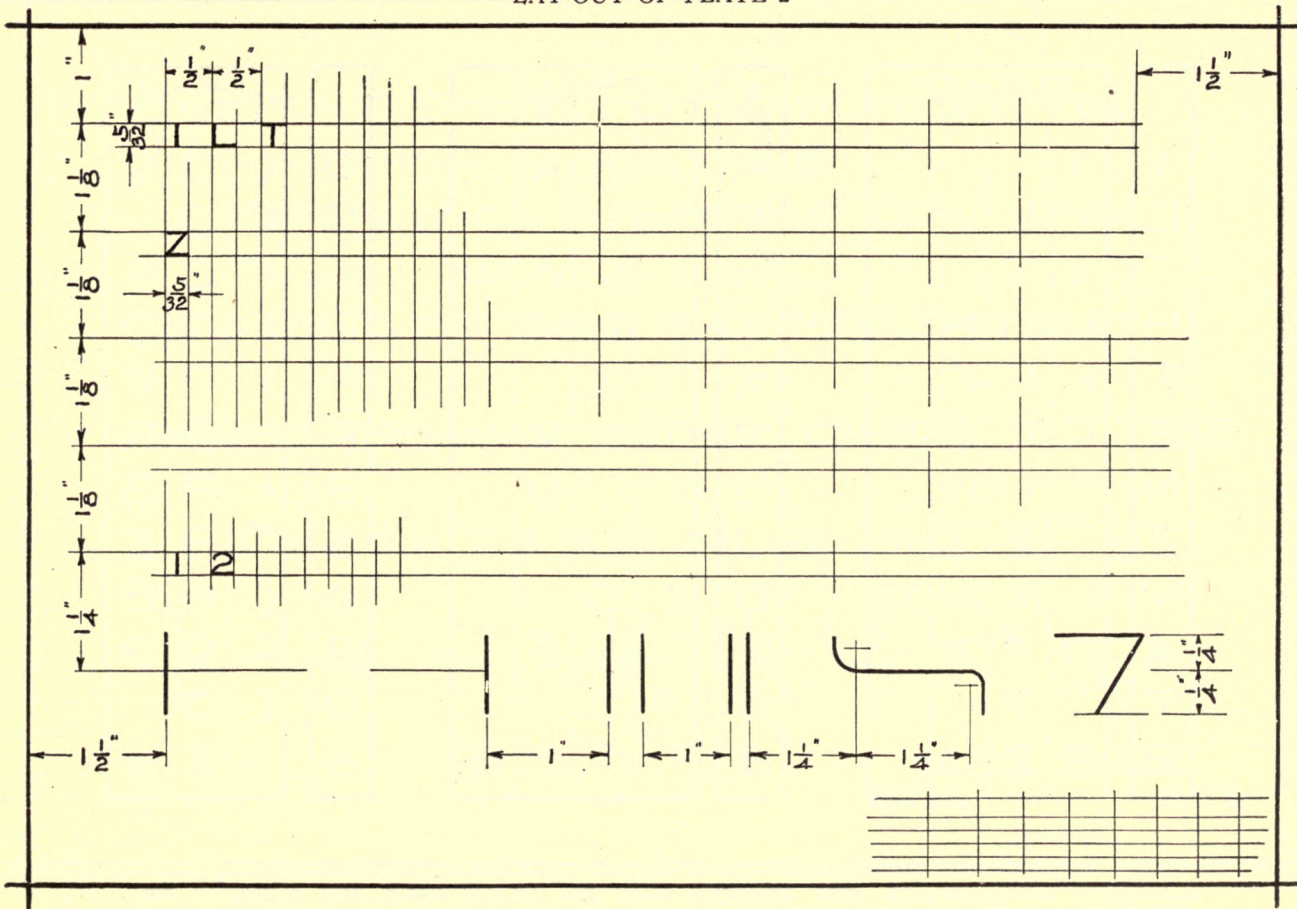

TABLE OF STROKES

	STROKES			
	1	2	3	4
I	I			
L	L	L		
T	T	T		
H	H	H	H	
F	F	F	F	
E	E	E	E	E
Z	Z	Z	Z	
N	N	N	N	
M	M	M	M	M
4	4	4	4	
7	7	7	7	
2	2	2	2	

	STROKES			
	1	2	3	4
5" $\frac{5}{32}$	A	A	A	
V	V	V	V	
W	W	W	W	W
K	K	K	K	
X	X	X	X	
Y	Y	Y	Y	
U	U	U	U	
O	O	O	O	
5	5	5	5	
3	3	3	3	
8	8	8	8	

	STROKES		
	1	2	3
Q	Q	Q	Q
G	G	G	G
D	D	D	D
P	P	P	P
R	R	R	R
B	B	B	B
S	S	S	S
6	6	6	6
9	9	9	9
0	0	0	0
&	&	&	&

Location dimensions are always laid out to full size, but should be omitted in the finished drawing.

I L T H F E LIFE LITHE FILE LIFT TILE

Z X M A V W K N Y EXAMINE ZEAL WEAK

U J O Q C G D P B S R & PROBLEMS QUIT

UPRIGHT FREEHAND GOTHIC CAPITAL LETTERS

1 2 3 4 5 6 7 8 9 0 35 25 7.90" 9½" 25/32"

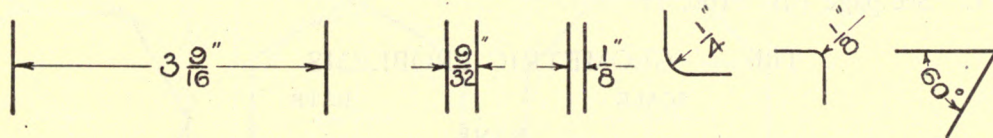

MAIN TITLE

SCALE

DATE

NAME

Specification—Plate 3.

With light lines draw 11 squares as shown in the plate on the opposite page. Each square contains a figure involving a geometric problem, the solution of which must be understood before the figure can be drawn. Study carefully the geometric problem referred to in each case.

- Sq. 1. Make the line 2" long. See page 188, Prob. 1.
 Sq. 2. See page 188, Prob. 2.
 Sq. 3. The vertex of the angle is located as shown. The angle is 60°. See page 188,
 Prob. 3.
 Sq. 4. The line is 2" long and is to be divided into 5 parts. See page 189, Prob. 4.
 Sq. 5. See page 189, Prob. 5.
 Sq. 6. Large arcs, 1" radius; small arcs, ½" radius. See page 189, Prob. 6.
 Sq. 7. The arcs have a radius of ½". See page 190, Prob. 7.
 Sq. 8. Large arc, ¾" radius; small arcs ⅜" radius. See page 190, Prob. 8.
 Sq. 9. Diameter of circle, 2½". See page 190, Prob. 9.
 Sq. 10. Diameter of circle, 2⅛". See page 191, Prob. 10.
 Sq. 11. See page 191, Prob. 11.

Title:— GEOMETRIC PROBLEMS

SCALE

DATE

NAME

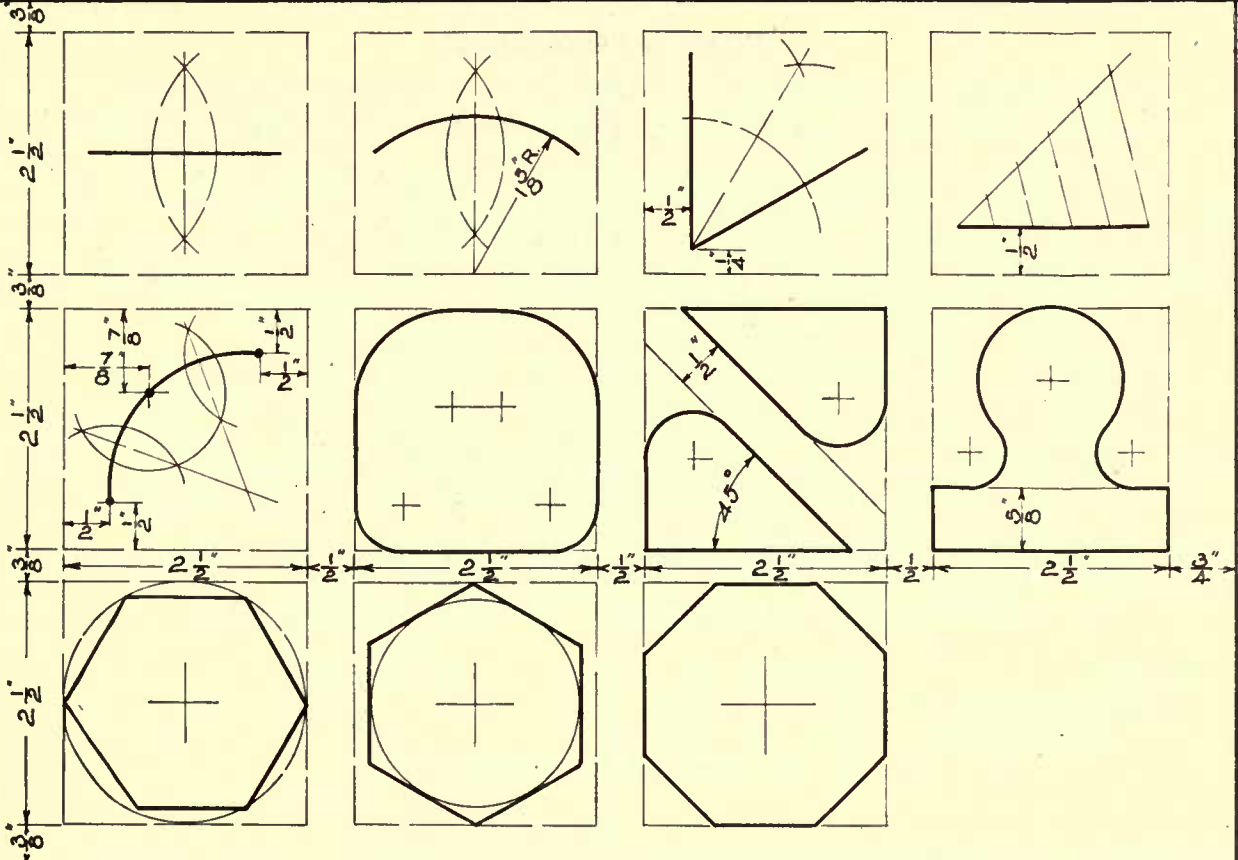

WORKING DRAWINGS.

A working drawing of an object is a group of completely dimensioned views of that object, so arranged and drawn that it will give all the information necessary to make the object.

A picture drawing of an object is a single view of the object represented as it appears to the eye when viewed or looked at from a stationary point. It shows only those parts, surfaces and edges, that can be seen from one point and does not show them in their true shape, proportion or relative size.

In a working drawing the object is viewed from many points—as many as are necessary to show all the edges, surfaces, etc., in their true shape and size. In a picture drawing we have one view of the object, in a working drawing we have two or more views, sometimes five.

It will be noticed in the working drawings on the opposite page that the invisible or hidden edges of an object are shown as well as the visible edges. They are represented by means of broken lines which indicate that they are hidden from view by some other part of the object.

1. How does a working drawing differ from a picture drawing of an object?
2. How many views should be shown in a working drawing of an object?
3. How are invisible or hidden edges of an object indicated in a working drawing?

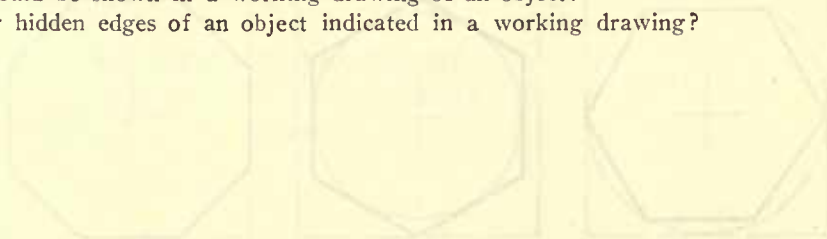

WORKING DRAWINGS

1

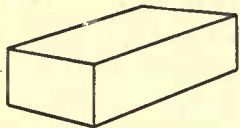

PICTURE DRAWING

1A

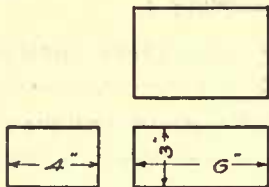

WORKING DRAWING

4

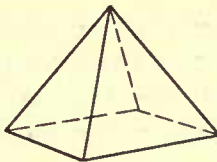

PICTURE DRAWING

4A

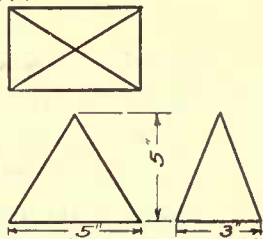

WORKING DRAWING

2

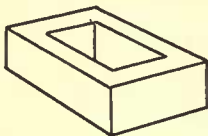

PICTURE DRAWING

2A

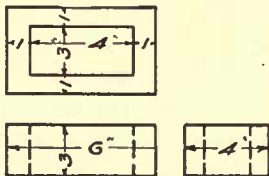

WORKING DRAWING

5



PICTURE DRAWING

5A

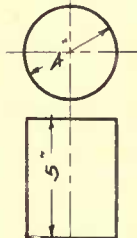

WORKING DRAWING

3

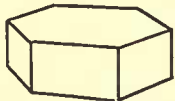

PICTURE DRAWING

3A

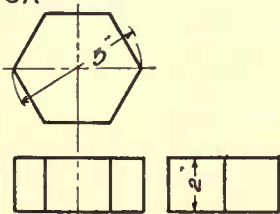

WORKING DRAWING

6



PICTURE DRAWING

6A

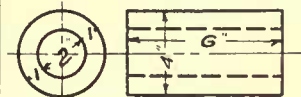

WORKING DRAWING

Specification—Plate 4.

Make a complete working drawing of the Lap-joint Piece, showing the front, top and right side views. The lay-out sheet on the opposite page gives the location of views and shows the front view complete. The top and side views are partially drawn and are to be completed with the aid of the front view and the picture drawing shown in the upper right-hand corner. Scale $12''=1'$.

Indicate all dimensions which are necessary and helpful to make the piece.

Title:— LAP-JOINT PIECE

SCALE

DATE

NAME

In a working drawing of an object one of its sides or surfaces is selected for the front view. It is drawn as it appears when held squarely in front of and on a level with the eye. The top view is drawn as it appears when the object is viewed squarely from above, and is placed directly above and in line with the front view. The side view is drawn as it appears when the object is viewed squarely from the side, and is placed directly opposite and in line with the front view. When the object is viewed from the right side, the side view is placed to the right of the front view; when it is viewed from the left side, the side view is placed to the left of the front view.

1. Is the top view placed directly above the front view?
2. Is the side view placed directly opposite the front view?
3. Where should the left side view be placed with reference to the front view?

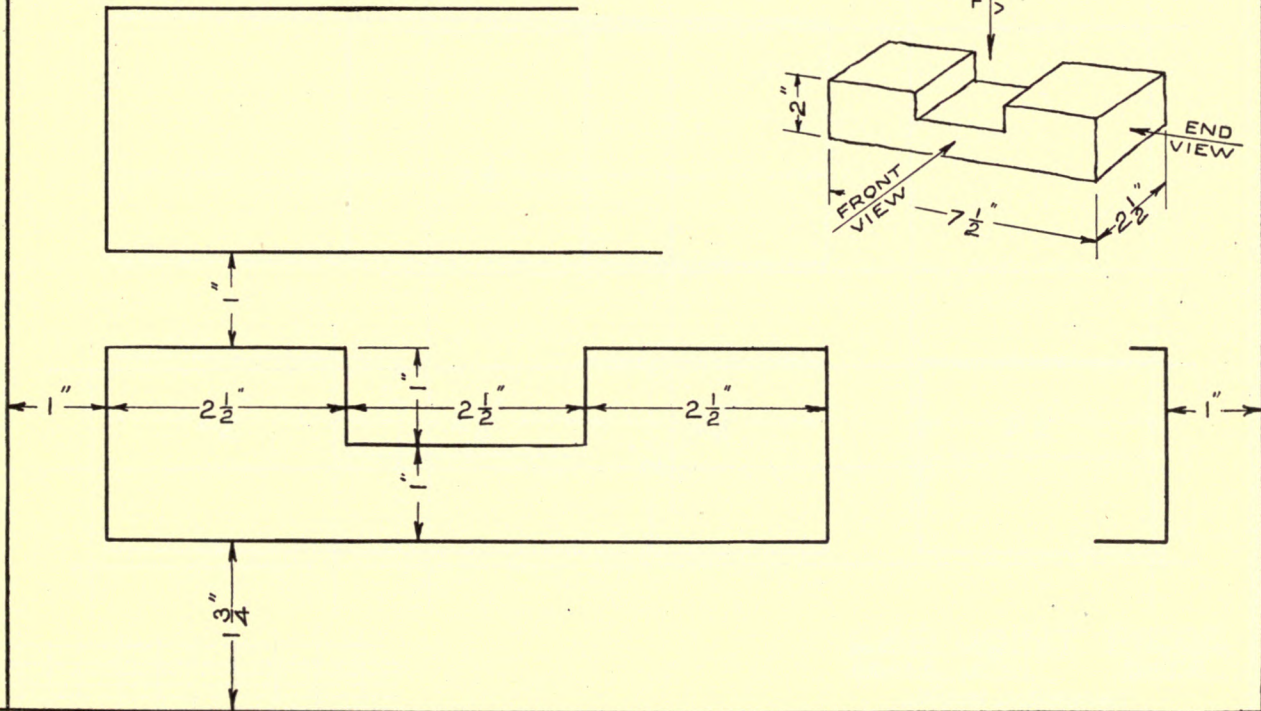

PENCIL LAY-OUT OF PLATE 4

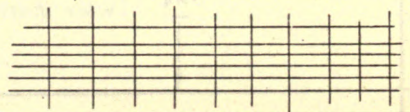
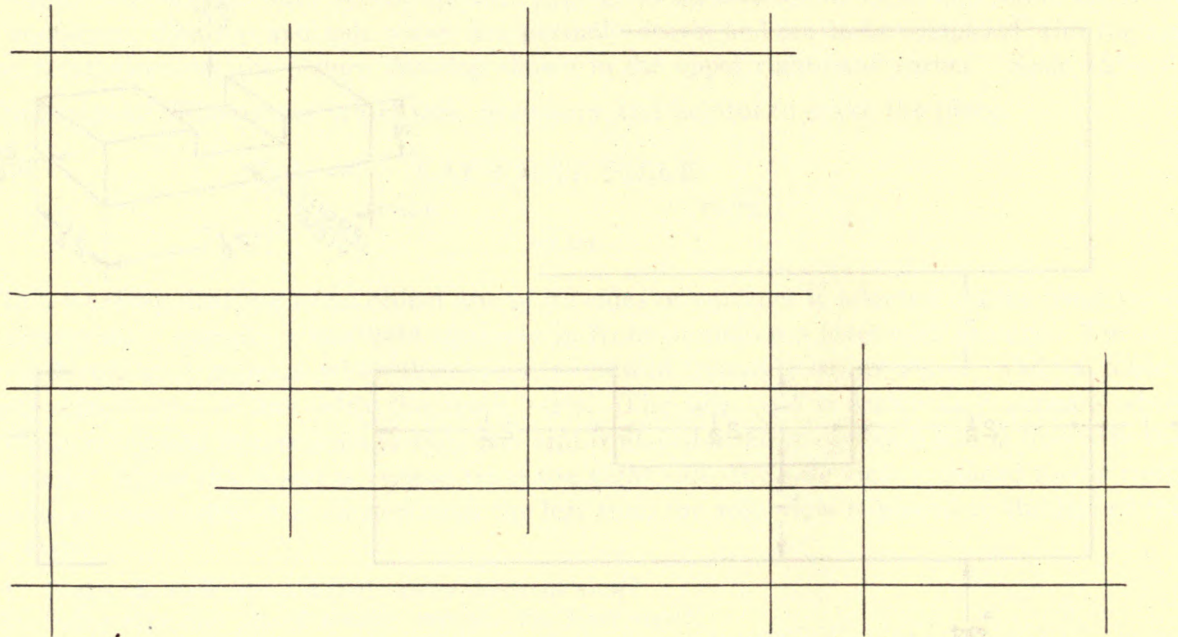

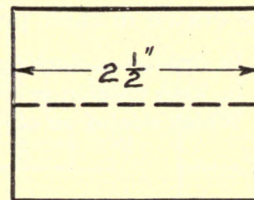
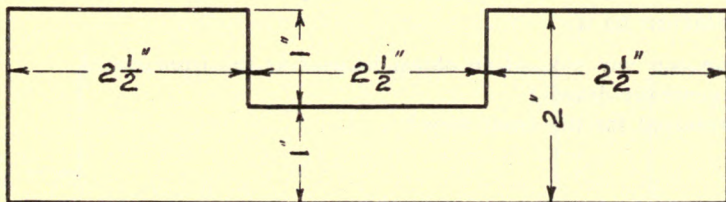
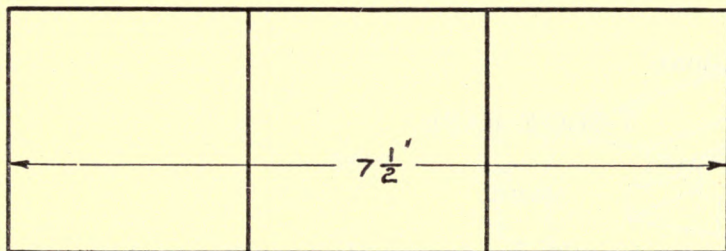

LAP JOINT PIECE
SCALE 12"=1' DATE
Sign Name

Note. It will be noticed that all dimensions are placed so as to read from the bottom edge or the right-

Specification—Plate 5.

Make a complete working drawing of the T-slot base, showing the front view, top view, and right-side view. The lay-out sheet gives the location of views and shows the side view completed. The front and top views are to be drawn with the aid of the side view and the picture drawing.

Indicate all necessary dimensions.

Title :— T-SLOT BASE

SCALE

DATE

NAME

Any side of an object can be used as the front view. It is customary, however, to place the object in its natural position and to use that side which shows clearly the most detail for the front view. When the front view has been determined upon, the top and side views must be drawn in their proper relation to it.

1. In making a working drawing can any side of an object be used as the front view?
2. In what position is an object generally drawn?
3. Which side of an object is preferred for the front view?

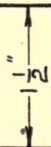
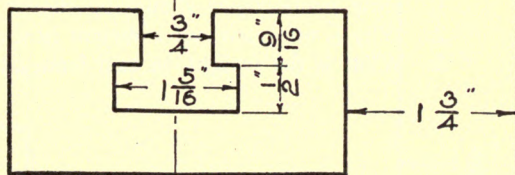
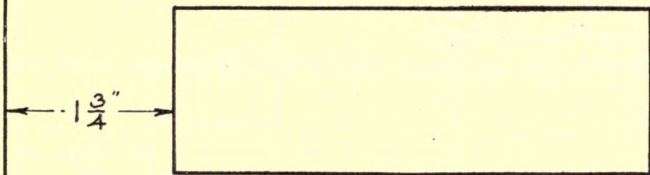
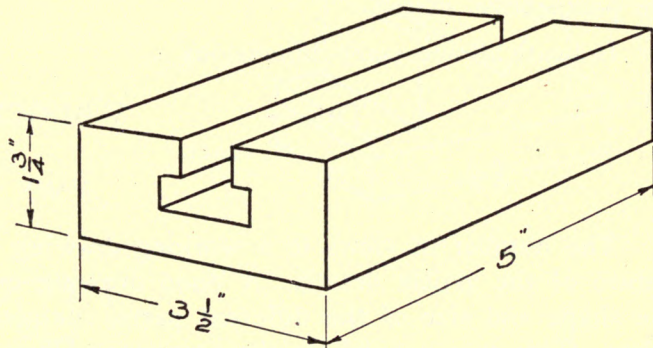
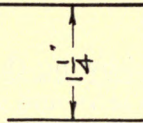

Specification—Plate 6.

Make a complete working drawing of the V-block, showing the front view, top view and right-side view. The lay-out sheet gives the location of views and shows the front view completely drawn. The top and side views are to be drawn with the aid of the front view and the perspective sketch.

Indicate all necessary dimensions.

Title:— V-BLOCK
SCALE DATE
NAME

The number of views in a working drawing depends upon the shape, construction and nature of the article drawn. A good drawing must show enough views to indicate clearly the shape and size of the different parts, surfaces and edges, and their relation each to the other. This may necessitate three or more views and should have at least two.

1. How many views should be shown in a working drawing of an object?
2. Why is one view not sufficient in a complete working drawing?
3. What is the weight, in cast iron, of the V-Block? The weight of cast iron is .26 lbs. per cubic inch.

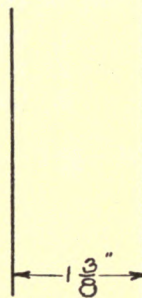
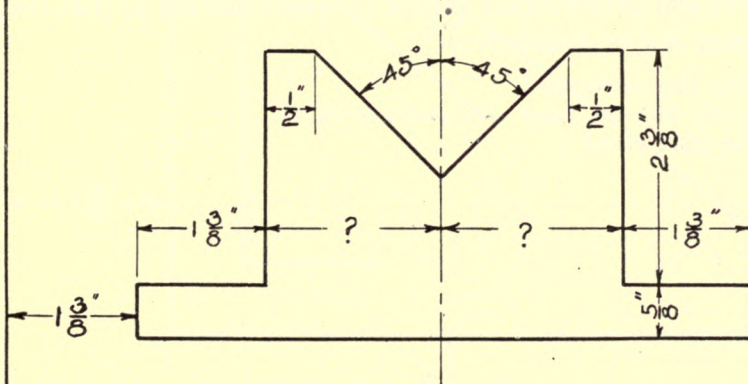
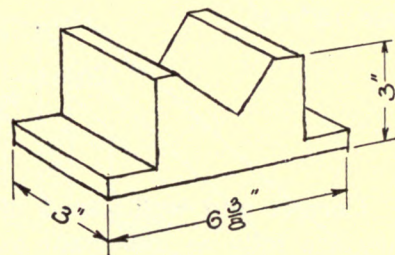
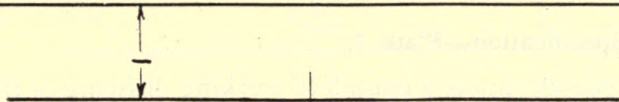

Specification—Plate 7.

With the aid of the perspective sketch, make a complete working drawing of the Bracket, showing the front view, top view and right-side view. Include all necessary dimensions. Scale 12"=1'.

Title:— BRACKET

SCALE

DATE

NAME

Correct and well-placed dimensions are a very important part of a working drawing. They are fully as important as the lines which indicate the shape of the object drawn and should be placed carefully. The figures and arrow-heads should be well executed so that they may be read easily and their meaning may not be mistaken.

1. Why are the dimensions on a drawing very important?
2. Is the drawing of the Bracket complete with the front view and side view?
3. Could all dimensions be shown in the front view?

$\frac{1}{2}$ "

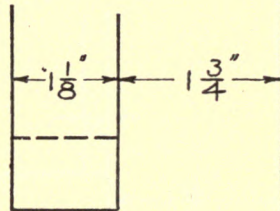
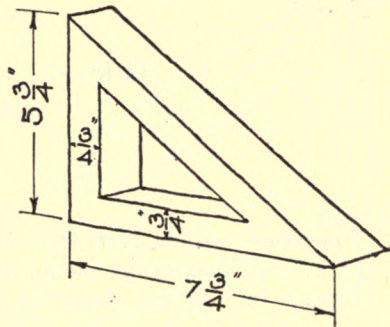
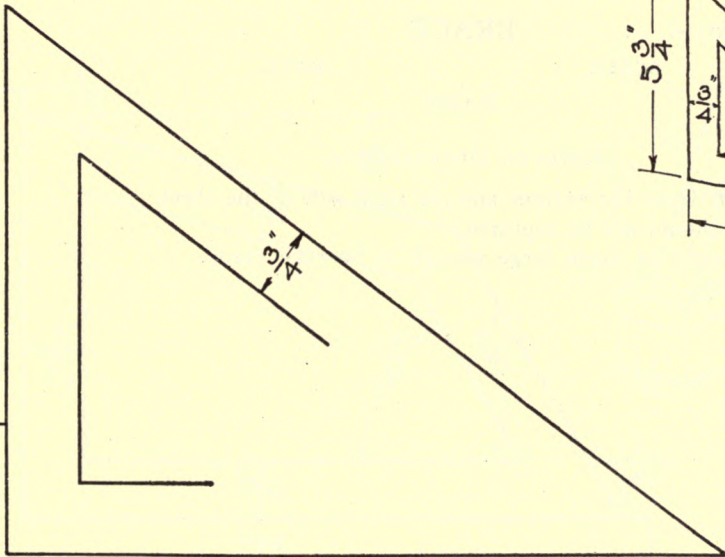

Specification—Plate 7A.

With the help of the perspective sketch, make a complete working drawing of the Brace, showing the front view, top view and right-side view. Indicate all necessary dimensions. Scale 12"=1'.

Title:—

BRACE

SCALE

DATE

NAME

NOTES ON DIMENSIONING.

1. Dimensions should read from the bottom and the right side of the sheet.
2. In general, dimensions should not be repeated.
3. Figures in fractions should be made large enough to be read easily.

$\frac{3}{4}$ "

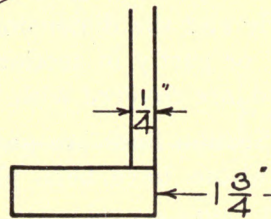
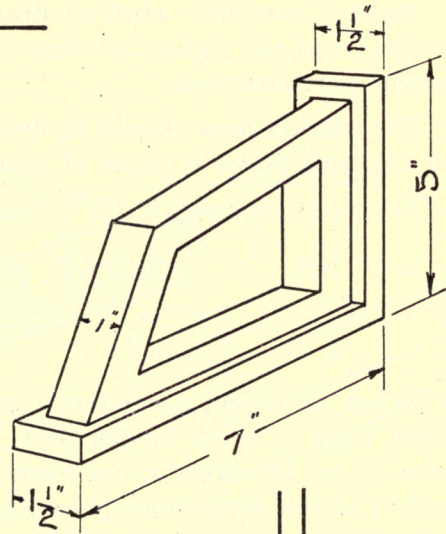
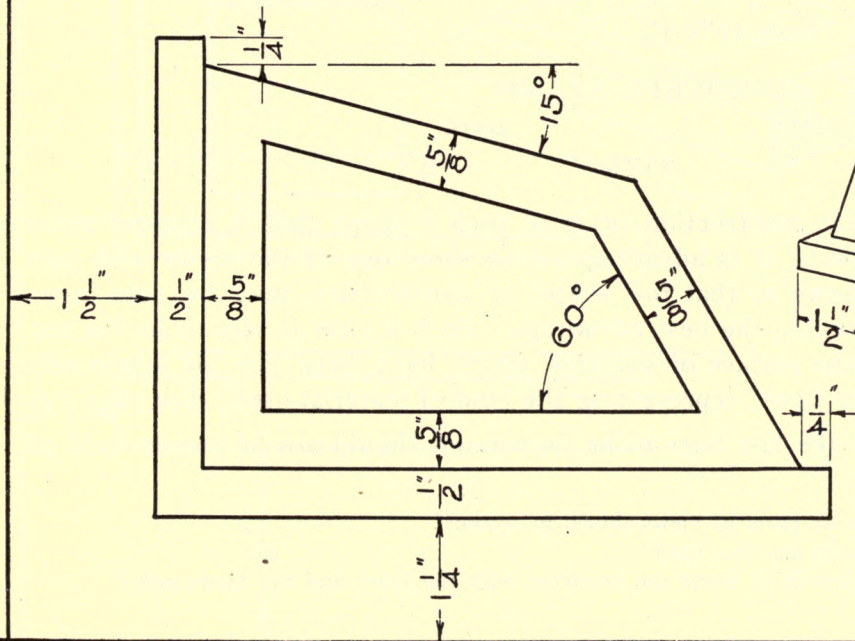

Specification—Plate 8.

Make a complete working drawing of the Ink-well Stand, showing the front view and top view, and the right-side view “in section” or as it would be seen if part A in the picture drawing were removed.

The section lines should be drawn light, and should indicate the kind of material used. The Ink-well Stand is made of cast-iron, wood or glass. See page 196.

The chamfers are $\frac{1}{4}'' \times \frac{1}{4}''$. Scale 12''=1'.

Title:— INK-WELL STAND

SCALE

DATE

NAME

When an object has interior construction or is of such a shape that it involves many broken lines to show hidden parts, it is advantageous to show one of the views with part of the object removed or cut away so that the shape or construction may be seen more clearly and the dimensions placed to the best advantage. Such a view is said to be “in section” or partly in section and the surface or surfaces which have been cut, or supposedly sawed, are covered with “section lines” representing the kind of material used. See page 196.

Section lines are generally the last lines to be drawn and should not be put on until all dimensions have been placed.

1. Why are views of an object or parts of views shown in section?
2. What are section lines and why are they used?
3. Why is the drawing of the Ink-Well Stand not complete with the front and top views only?

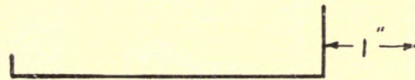
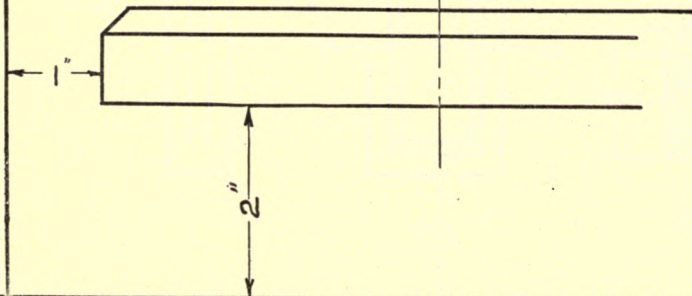
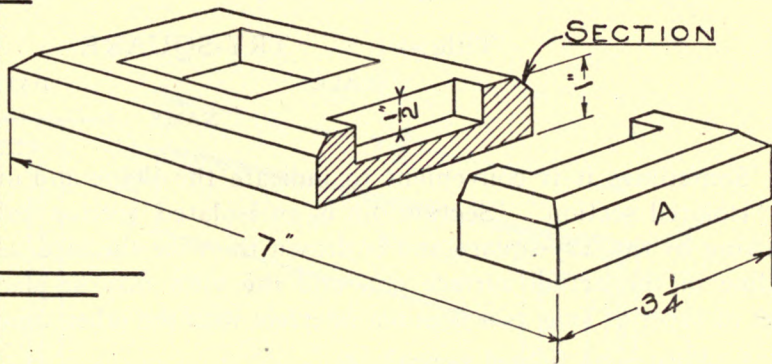
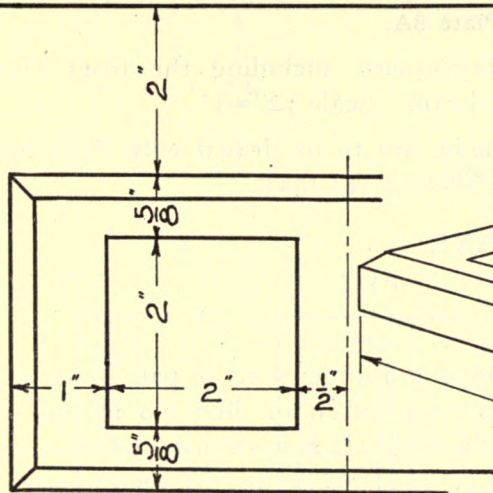

Specification—Plate 8A.

Make a complete working drawing of the Try-square, including the front view, top view, left-side view and an isolated section of the beam. Scale $12''=1'$.

The graduations, or division marks on the blade, are to be drawn with light lines and are $\frac{1}{8}''$, $\frac{1}{4}''$, $\frac{3}{8}''$ and $\frac{1}{2}''$ long respectively. The blade is $\frac{1}{16}''$ thick.

Title:— TRY-SQUARE

SCALE

DATE

NAME

Sometimes it is convenient to indicate the shape and dimensions of part of an object by an "isolated section." Section o-o is an isolated section taken on line o-o in the working drawing of the Try-square and is drawn to twice the size. It is customary to show only the outline of the actual surface cut, and the view may be placed at any convenient place on the sheet of paper as long as it does not interfere with the other views.

1. What is an isolated section?
2. Why is it used?

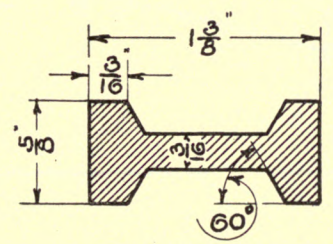
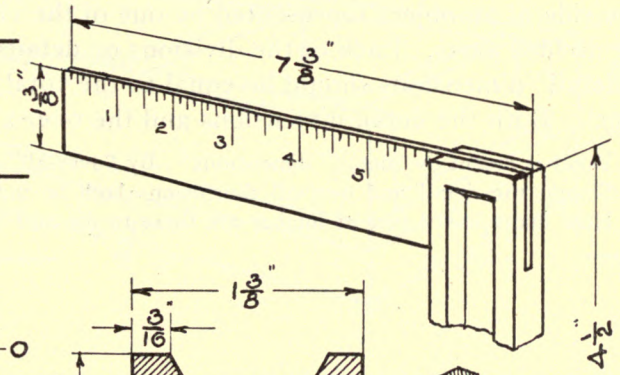
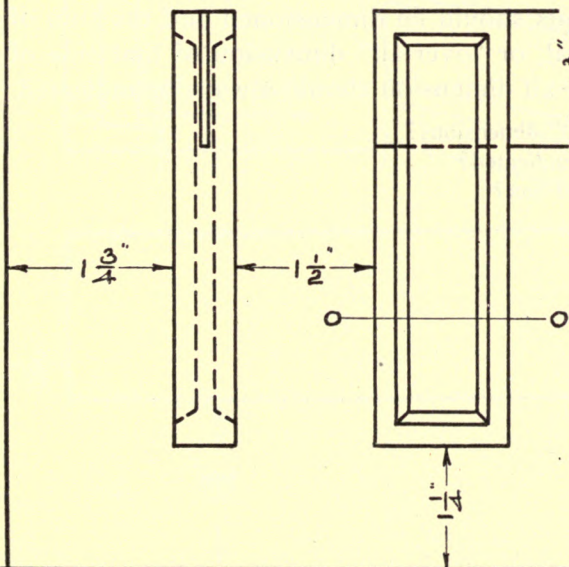
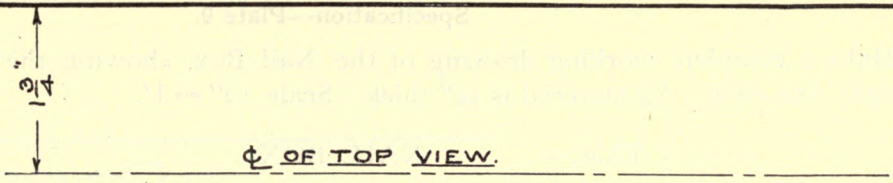

SECTION O-O

Specification—Plate 9.

Make a complete working drawing of the Nail Box, showing the front view, top view and right-side view. All material is $\frac{3}{8}$ " thick. Scale 12" = 1'.

Title:— NAIL BOX

SCALE

DATE

NAME

The side of an object represented by one of the views often consists of many separate surfaces or divided parts. Each of the divisions or details should be dimensioned and the sum of these "detail" dimensions should be equal to the total, or "over-all" dimension of that side of the object. Both the detail dimensions and the over-all dimension should always be indicated.

1. What is meant by "detail" dimensions? By "over-all" dimensions?
2. Should the detail and over-all dimensions both be indicated?
3. How many board feet of lumber are there in the nail box?

PLATE 9

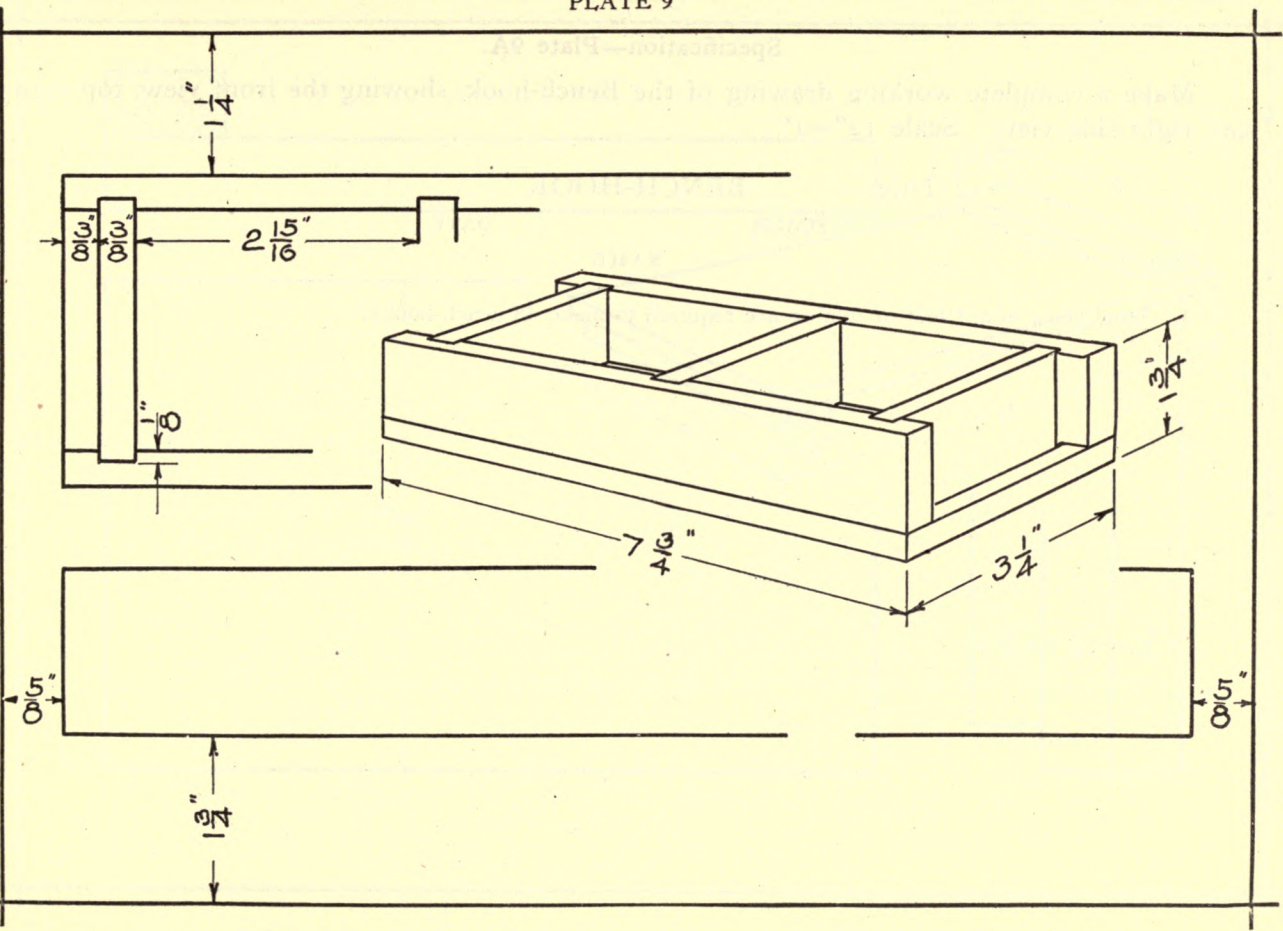

Specification—Plate 9A.

Make a complete working drawing of the Bench-hook, showing the front view, top view and right-side view. Scale 12"=1'.

Title:— BENCH-HOOK

SCALE

DATE

NAME

1. How many board feet of lumber are required to make 48 bench-hooks?

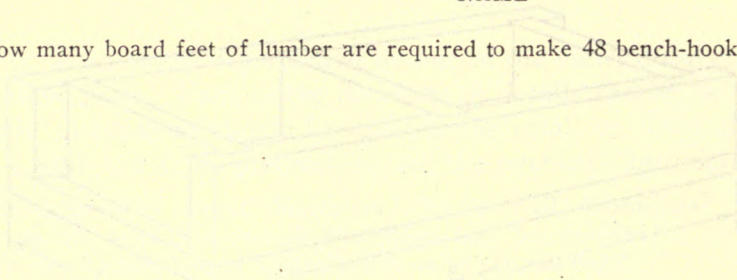
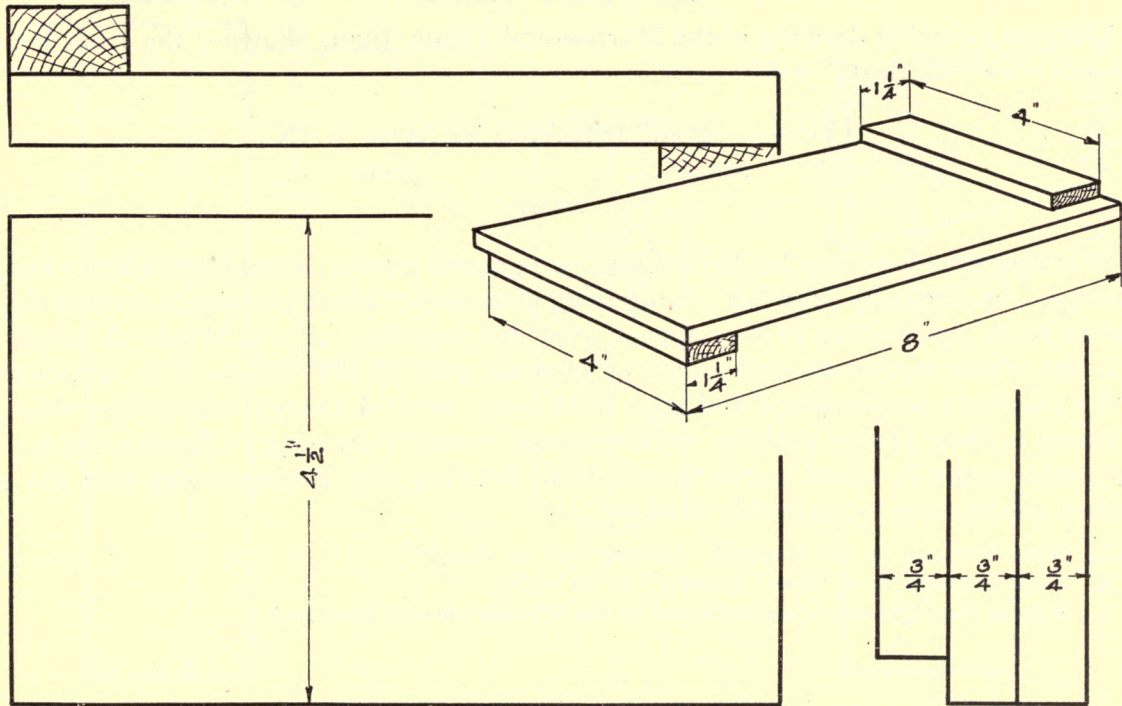

PLATE 9A



Specification—Plate 10.

Make an assembly drawing of the Mortise-and-Tenon Joint, showing the front view and right-side view. Scale 12"=1'.

Title:— MORTISE-AND-TENON JOINT

SCALE

DATE

NAME

Working drawings may be divided into two general classes: assembly drawings and detail drawings. An assembly drawing is a drawing of an object which consists of several distinctly separate parts, represented as they appear when put together, or assembled. A detail drawing is one which represents each single or separate part of the object. The workmen who cut the stones to proper shape and size, work from detail drawings; the builder who places the stones in their proper position works from an assembly drawing. Likewise, the machinist who machines the fly-wheel works from a detail drawing; the mechanic who puts the engine together works from an assembly drawing.

1. What is meant by an "assembly drawing" of an object?
2. What is meant by a "detail drawing" of an object?
3. Why is the right-side view preferred to the left-side view in this case?

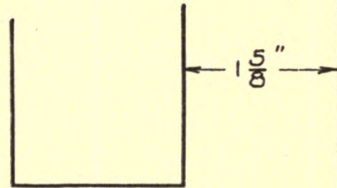
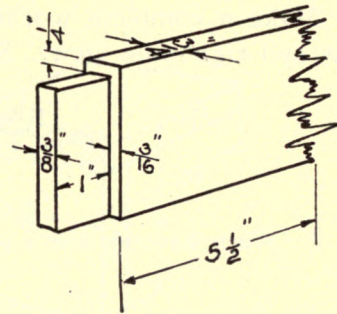
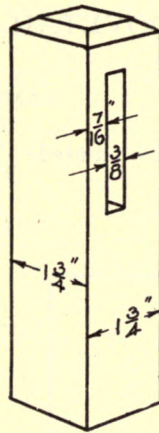
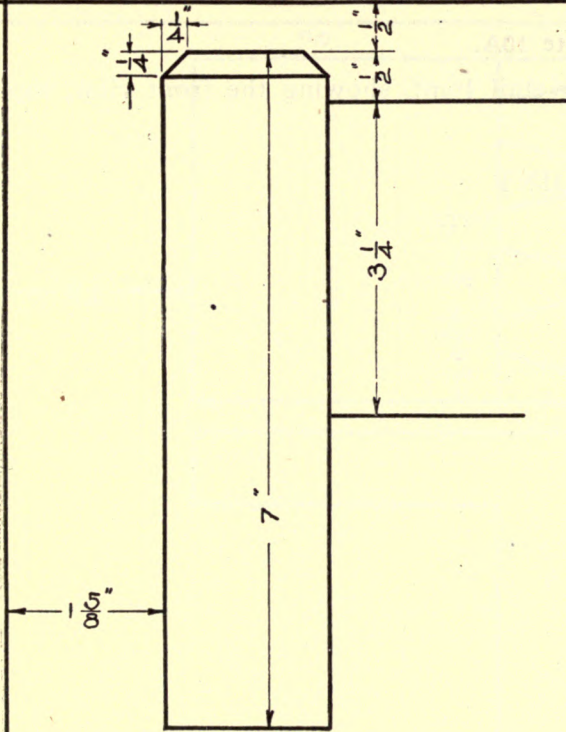

Specification—Plate 10A.

Make a complete working drawing of the Dovetail Joint, showing the front view, top view and right-side view. Scale 12"=1'.

Title:— DOVETAIL JOINT

SCALE

DATE

NAME

1. Where have you seen a joint of this kind used?

PLATE 10A

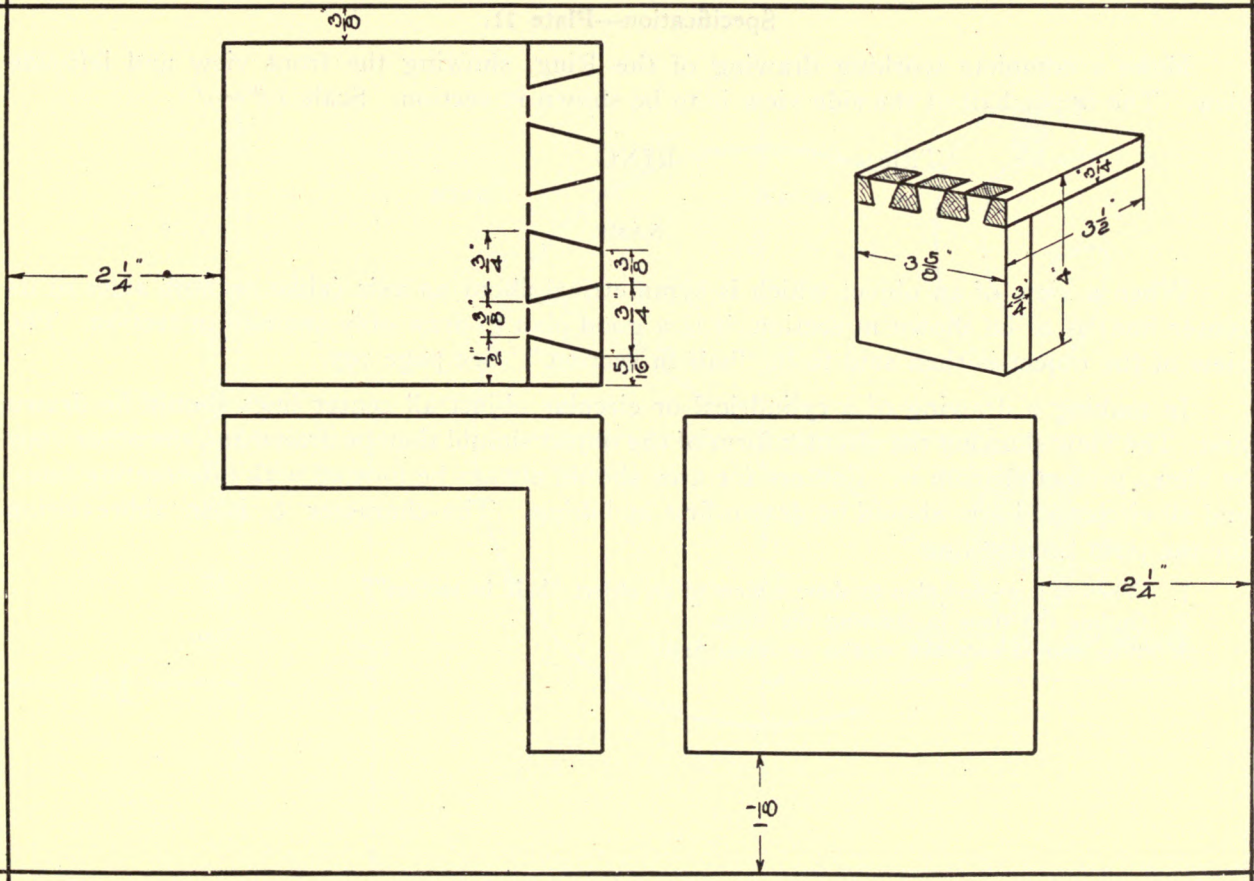

Specification—Plate 11.

Make a complete working drawing of the Ring, showing the front view and left-side view. The upper half of the side view is to be shown in section. Scale 12"=1'.

Title:—

RING

SCALE

DATE

NAME

When a view of an object which is symmetrical about an axis (alike on both sides of its center line) is to be shown in section, it is a good plan to draw only one-half in section. The view of the object is then said to be "half in section." See page 197.

In making a drawing of a cylindrical or circular object all center lines should be drawn first. The view showing the circular form of the object should then be drawn and the other view or views projected from it. Centers for arcs should always be located with intersecting lines, and all circles and arcs should be drawn first in inking. The character ϕ is an abbreviation for the term "center line."

1. When is it a good plan to show a view of an object "half in section"?
2. Outline the steps in drawing the Ring.
3. Why should arcs and circles be inked first?

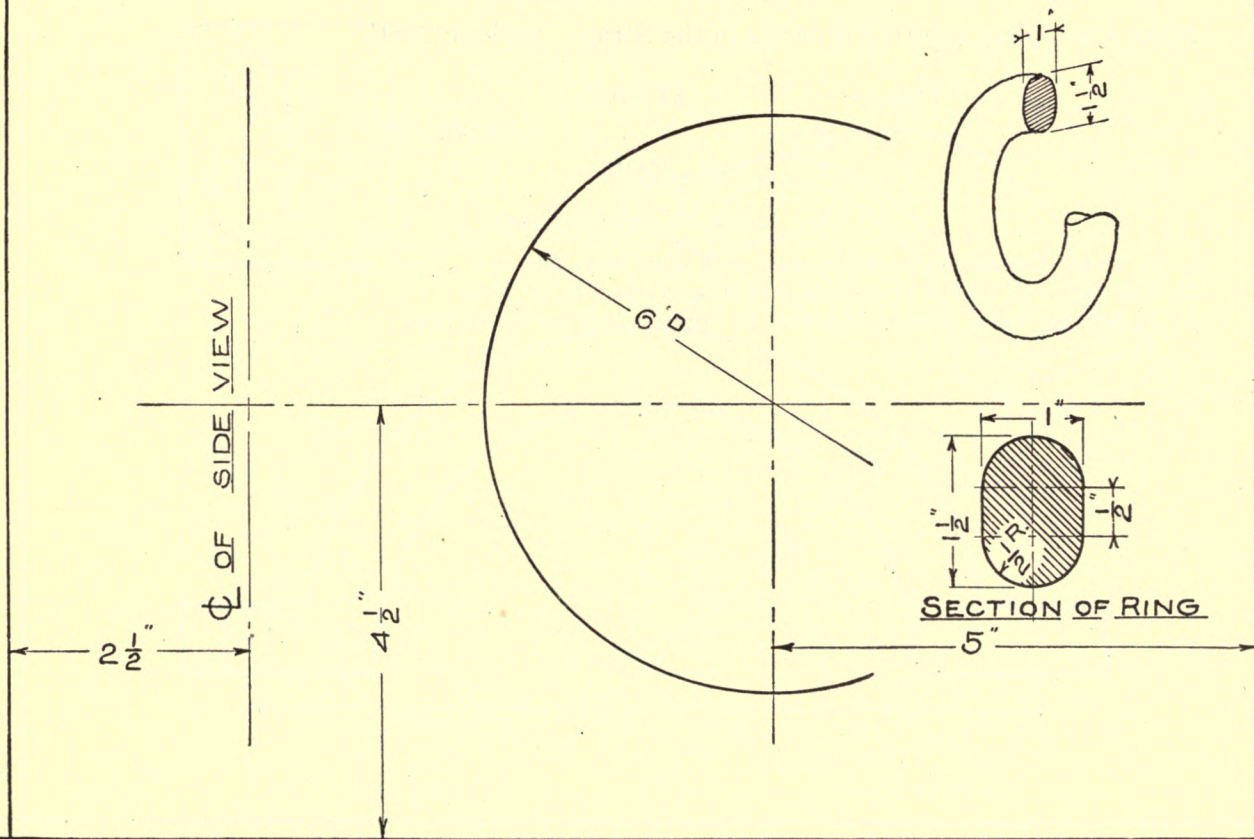

Specification—Plate 11A.

Make a complete working drawing of the Strap. Scale 12"=1'.

Title :— STRAP

SCALE

DATE

NAME

NOTES ON DIMENSIONING.

1. A center line should never be used as a dimension line.
2. The radius of an arc of a circle should be marked R, or RAD.
3. In locating holes, always indicate the distance between center lines.

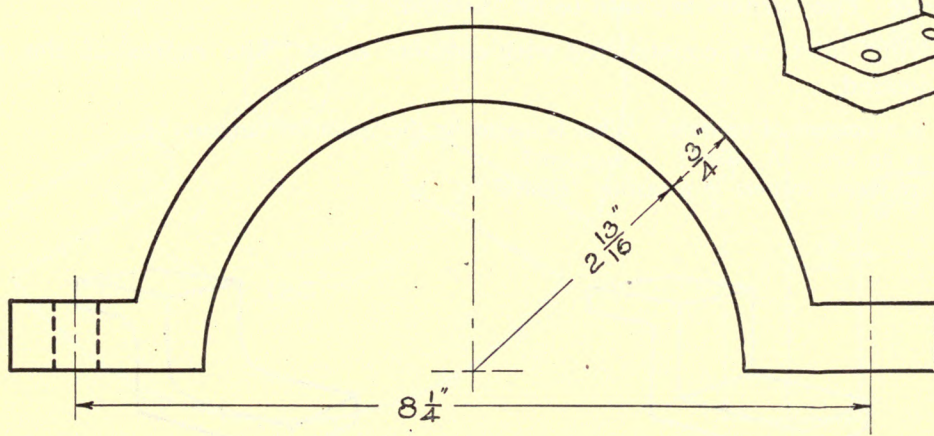
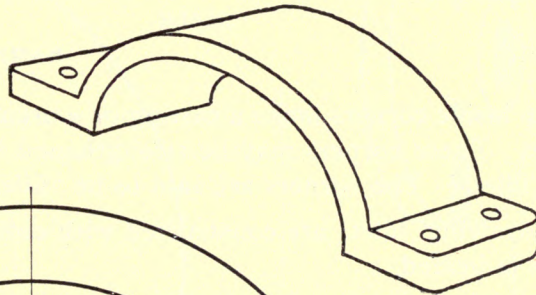
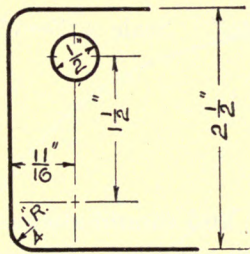

Specification—Plate 12.

Make a complete working drawing of the Face-plate. Bore $\frac{7}{8}$ ". Scale 12"=1'.

Title:— FACE-PLATE

SCALE

DATE

NAME

Sharp inside corners make a casting or a machine part weak, and should always be avoided if possible. These corners may be strengthened by making them rounded. This rounding is called a "fillet." The corners are said to be "filleted."

In a drawing, fillets are constructed with circular arcs. The radius of the arcs should always be indicated.

1. What is a tangent of a circle? What is meant by the "point of tangency"?
2. What is an arc? A chord? A segment?
3. Why are inside corners in a casting "filleted"?

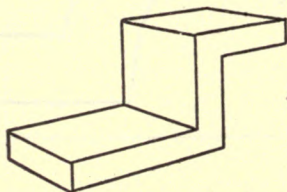

Without Fillets.

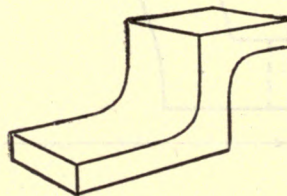

Filleted

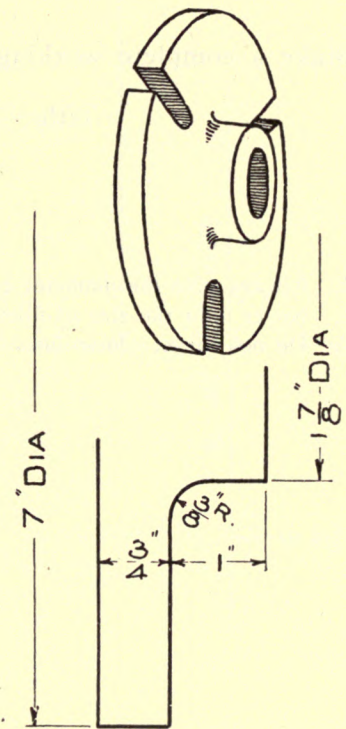
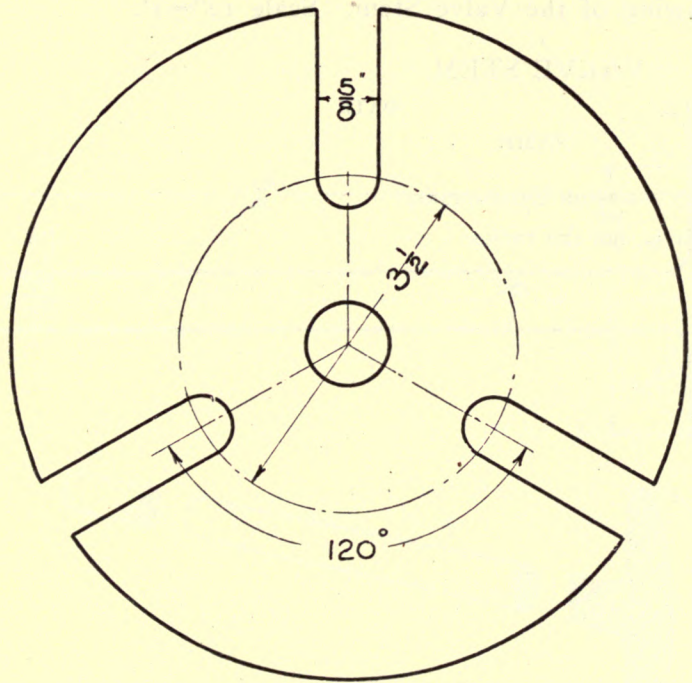

Specification—Plate 12A.

Make a complete working drawing of the Valve Stem. Scale 12"=1'.

Title:— VALVE STEM

SCALE

DATE

NAME

NOTES ON DIMENSIONS.

1. Always give the diameter of a circle, not the radius.
2. Never omit the size of fillets.
3. Do not forget center lines.

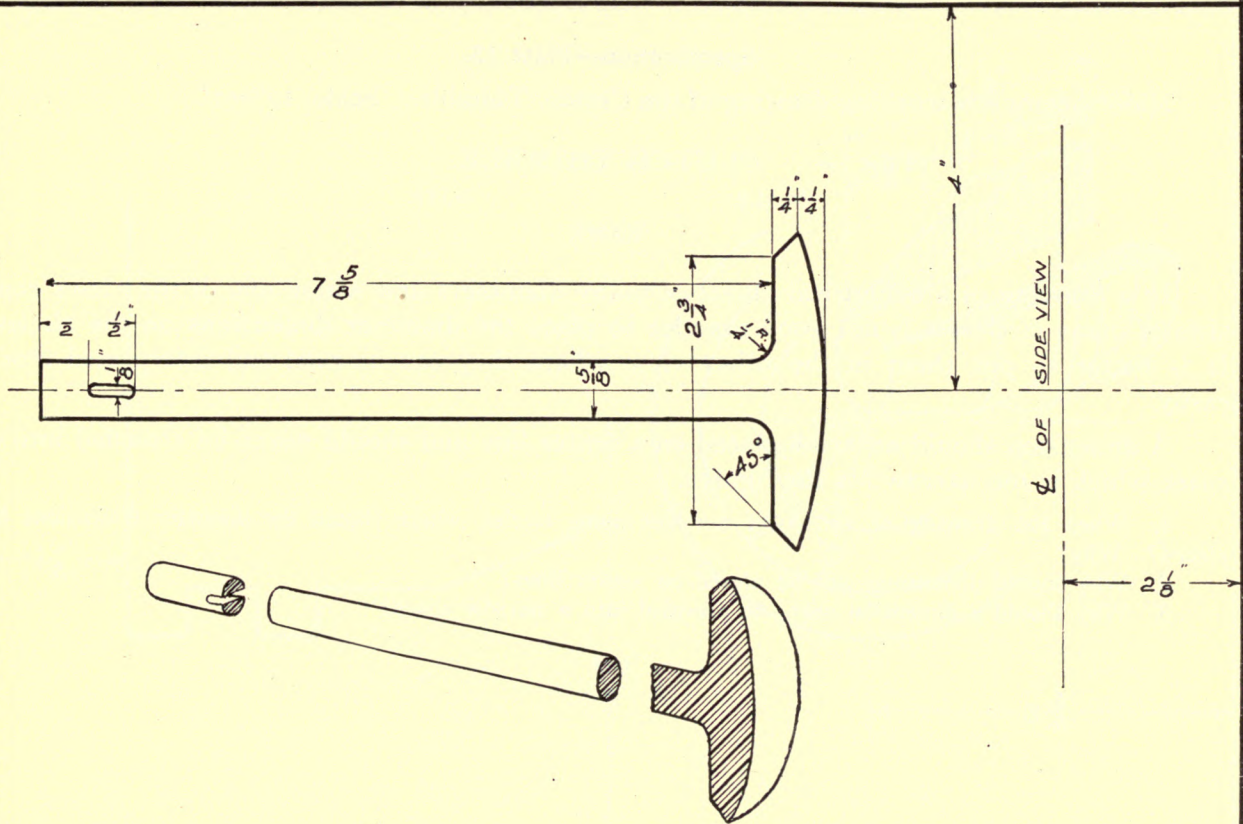

Specification—Plate 13.

Make a complete working drawing of the Clutch Thimble. Scale 12"=1'.

Title:— CLUTCH THIMBLE

SCALE

DATE

NAME

In a drawing of a cylindrical object of many diameters and where one of the views consists of many circles, it is not good practice to place the diameter dimensions on the circles. It is better to put them in the other view where they can be read and interpreted more easily.

A dimension should never be placed on a center line and should never be crowded into a space which is too narrow for the figures.

1. When the drawing of an object involves many circles, where should the diameter dimensions be placed? Why?
2. Why should dimensions not be placed on center lines?
3. Why should a dimension never be crowded into a narrow space?

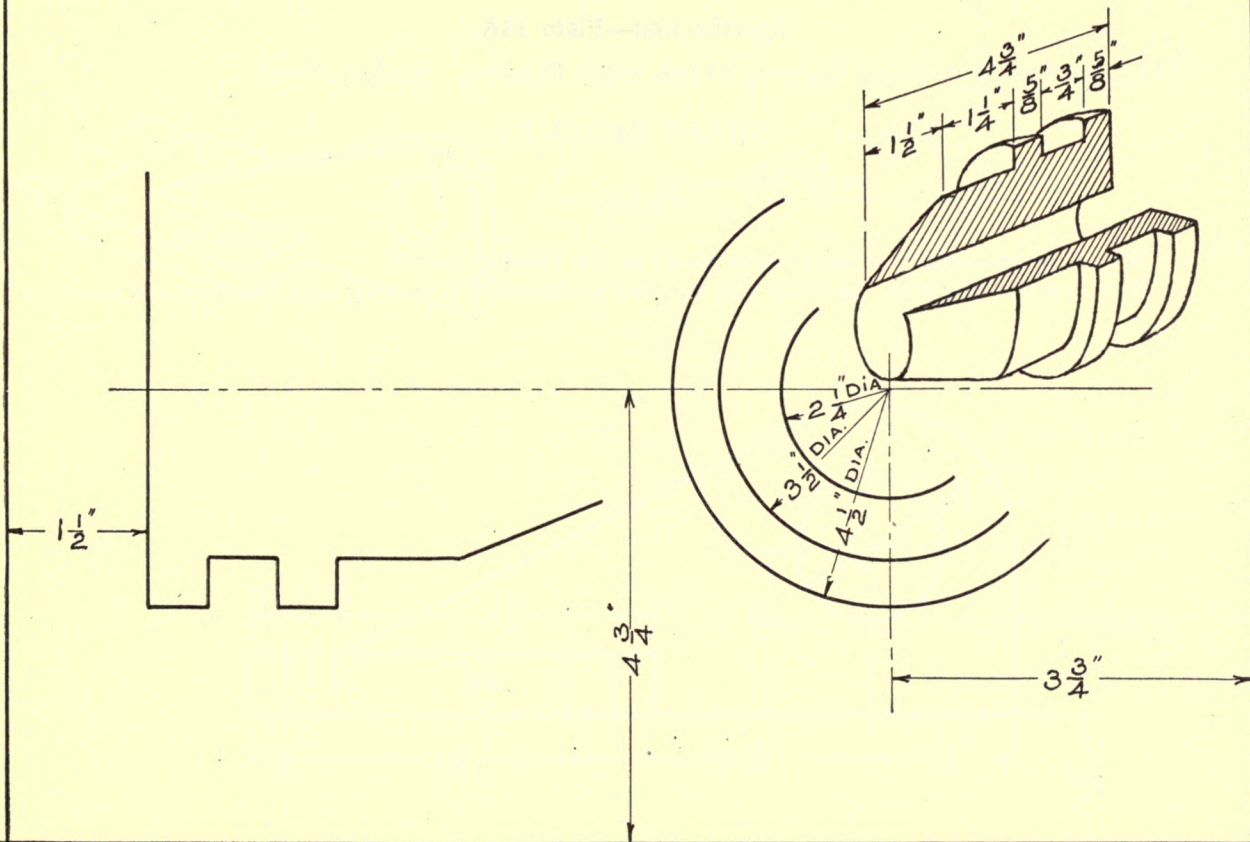

Specification—Plate 13A.

Make a complete working drawing of the Shaft Bracket. Scale 12"=1'.

Title:— SHAFT BRACKET

SCALE

DATE

NAME

1. Why is it unnecessary to draw three views of the Shaft Bracket?
2. Why is a drawing with the front and top view preferred to a drawing with the front and side view?

PLATE 13A

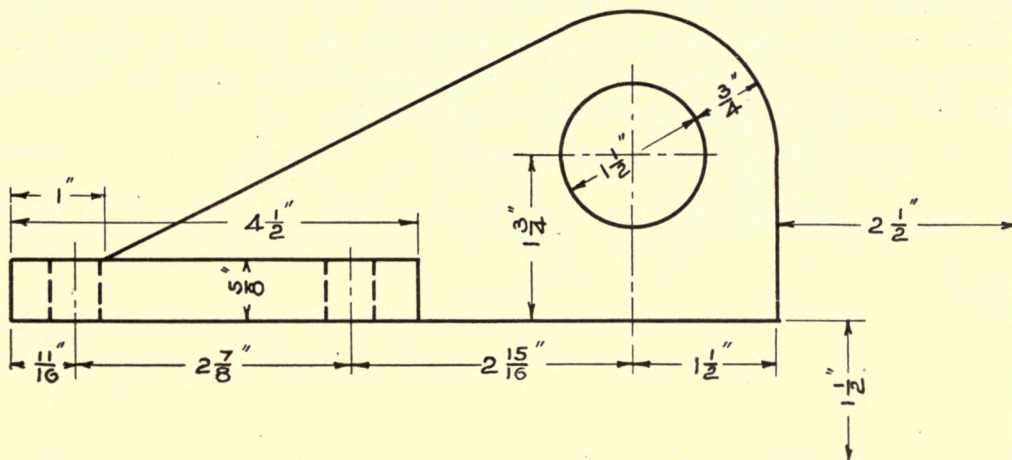
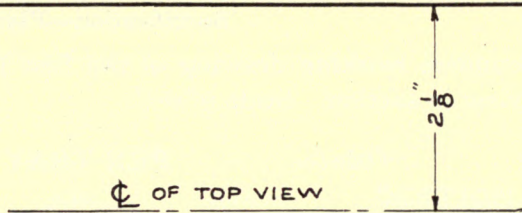
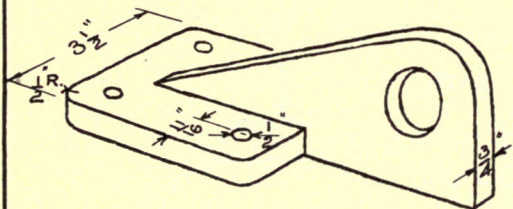

Specification--Plate 14.

Make a complete working drawing of the Pen Tray, showing the front and top view and the right-side view in section. Scale $9''=1'$.

Title:— PEN TRAY

SCALE

DATE

NAME

KEEP THE RULING PEN CLEAN.

Drawing ink consists of a black pigment held in solution with an acid. The acid evaporates quickly so that lines drawn with the ink will dry rapidly. The ruling pen must therefore be cleaned constantly as the ink becomes thick and sluggish between the points of the nibs. When this occurs the ink does not flow freely and the result is a ragged line or no line at all. While inking, a soft cloth should be used occasionally to wipe out the thick ink and to keep the nibs clean and bright both inside and outside.

1. Why should a ruling pen be kept clean?

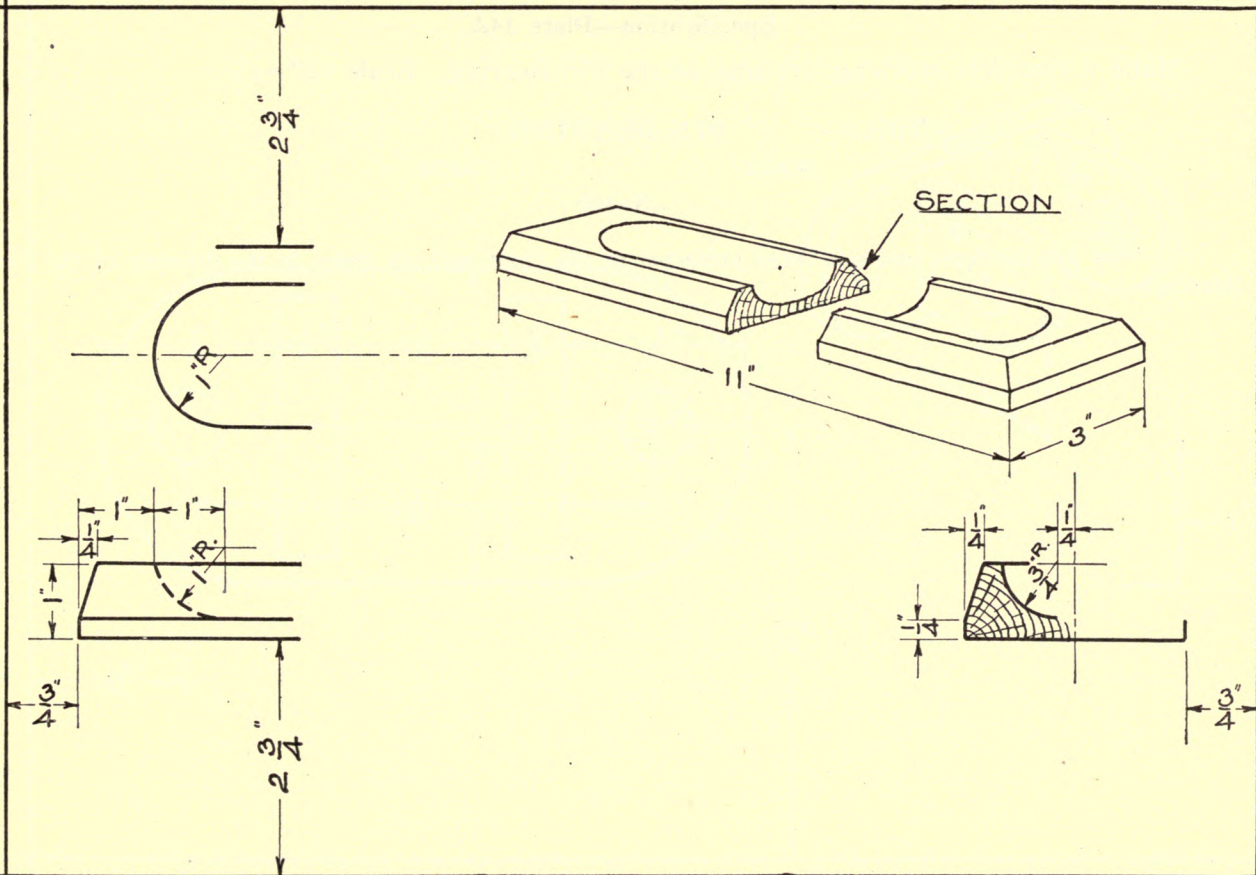

Specification—Plate 14A.

Make a complete working drawing of the Pin Bearing. Scale 12"=1'.

Title:— PIN BEARING

SCALE

DATE

NAME

1. Why are the front and side views preferred to the front and top views in the drawing of the Pin Bearing?

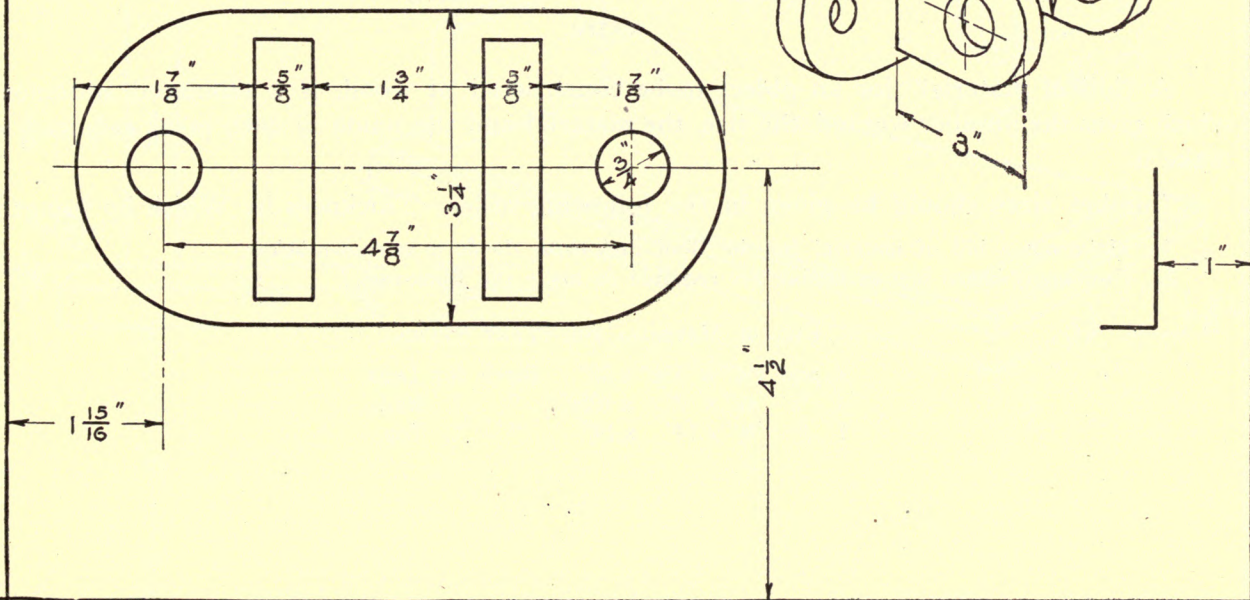

Specification—Plate 15.

Make an assembly drawing of the Book-rack showing two views. The construction should be shown and all parts dimensioned. In the picture drawing one end is removed to show the construction. Scale 6"=1'.

Title:— BOOK-RACK

SCALE

DATE

NAME

A "bill of material" for an object to be constructed of wood, is a tabulated statement which gives the number wanted, the size, the material and the name of each piece required to make it.

Lumber sizes should be given in the following order: Thickness by Width by Length.

1. Make out a bill of material for the Book-rack using the form as shown below.
2. How many board feet of lumber are required to make the Book-rack?

BILL OF MATERIAL FOR PLANT STAND.

4	pcs.	1¼"	x	1¼"	x	22"	Birch	for	Legs
4	"	¾"	x	2"	x	10½"	"	"	Rails
1	"	¾"	x	14"	x	14"	"	"	Top

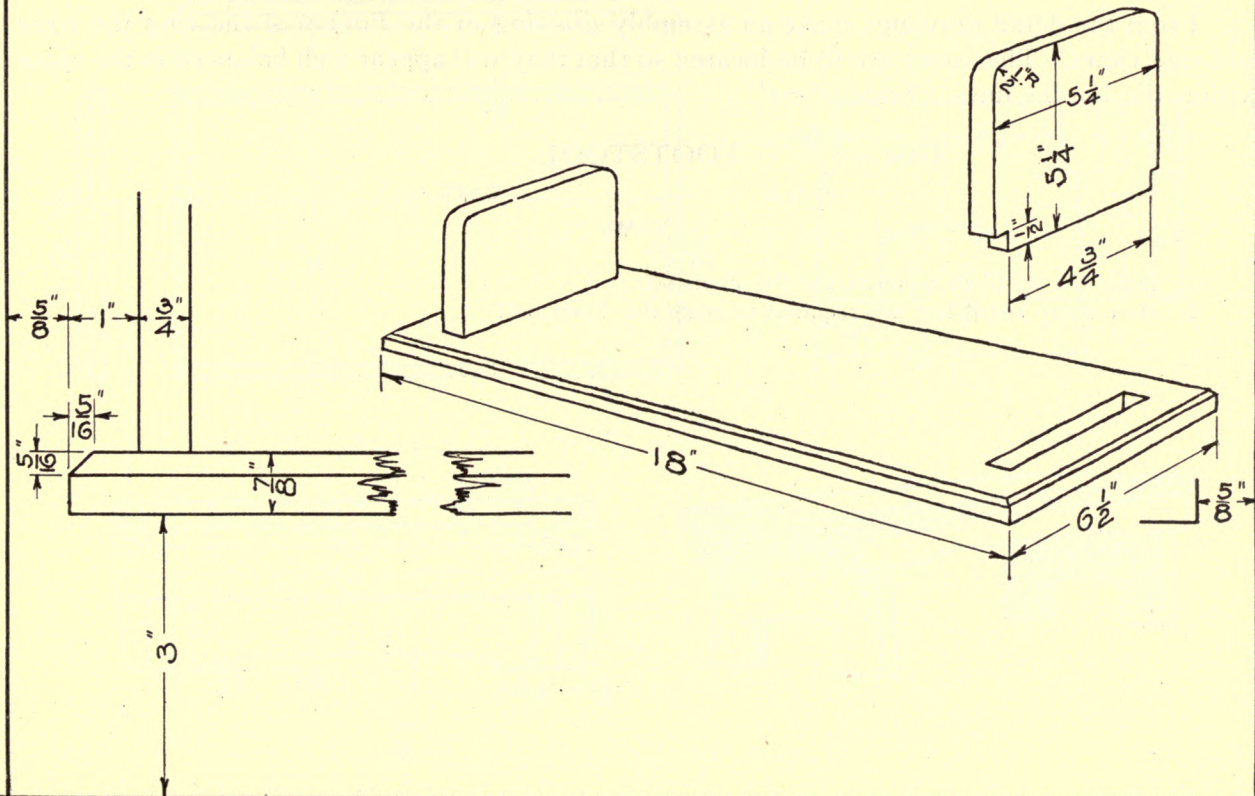

Specification—Plate 15A.

From the detail drawings make an assembly drawing of the Footstool showing the front and side views. The views are to be located so that they will appear well balanced in the space within the border lines. Scale $6''=1'$.

Title:— FOOTSTOOL

SCALE

DATE

NAME

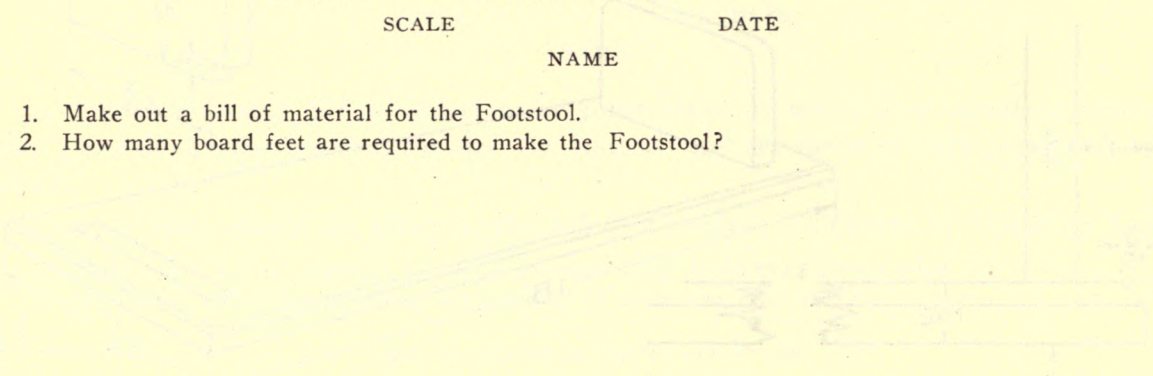
1. Make out a bill of material for the Footstool.
 2. How many board feet are required to make the Footstool?
- 

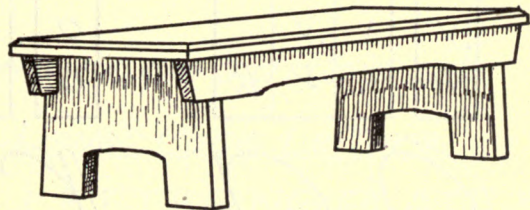
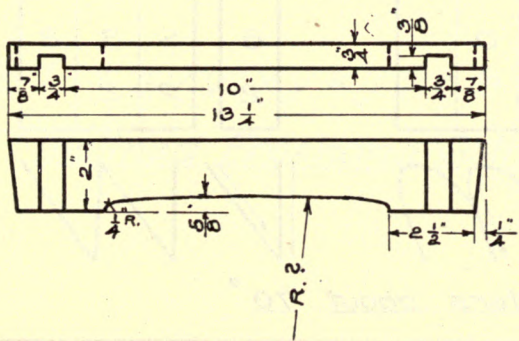
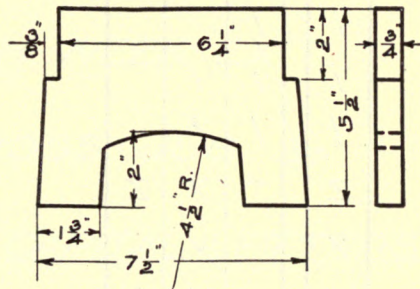
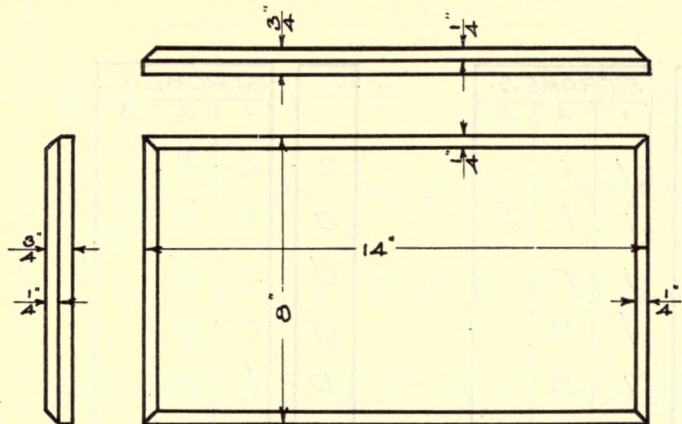
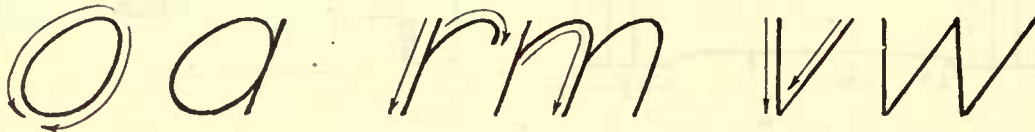

TABLE OF STROKES

	STROKES		
	1	2	3
l	l		
i	l	i	
t	l	t	
z	-	7	z
v	v	v	
w	v	v	w
x	\	x	
y	\	y	
k	l	k	k

	STROKES		
	1	2	3
j	J	j	
f	l	f	f
r	l	r	
h	l	h	
n	l	n	
m	l	n	m
u	l	u	
o	c	o	
c	c		

	STROKES		
	1	2	3
e	c	e	
a	c	a	
d	c	d	
g	c	g	
b	l	b	
p	l	p	
s	s	s	
8	s	8	8
2	2	2	



Slant of letters about 70°

I L T H F E LITTLE FLEET TELL LET ← 1 1/2" →

Z N M A V W K X Y ZENITH WEEK EXIT

U J O Q C G D P R B S CROSS JUG &

INCLINED FREEHAND GOTHIC CAPITAL LETTERS

1 4 7 2 5 3 0 6 9 8 61.853" 7 1/2" 8 3/4" 22/32"

i t z v w x y k j f r h n m u o c e a d g q b p s

Inclined Freehand Gothic Lower Case Letters.

LETTERING PLATE B

DATE

NAME

PLANES OF PROJECTION

①

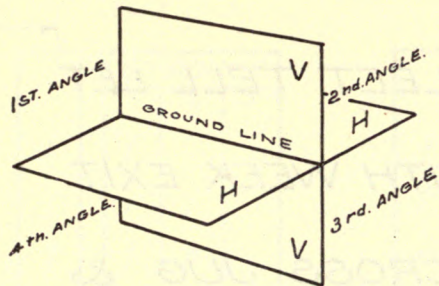

ANGLES OF PROJECTION, SHOWING THE VERTICAL AND HORIZONTAL PLANES.

②

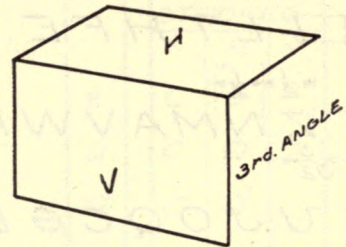

3rd. ANGLE OF PROJECTION, SHOWING THE VERTICAL AND HORIZONTAL PLANES.

③

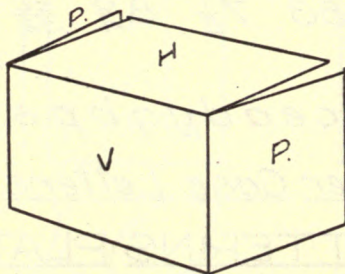

3rd. ANGLE OF PROJECTION, SHOWING THE VERTICAL, HORIZONTAL AND PROFILE PLANES.

④

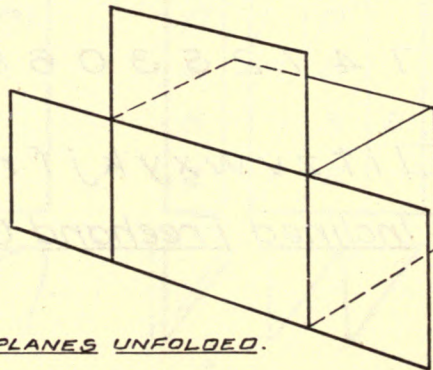

PLANES UNFOLDED.

PLANES OF PROJECTION (Continued)

⑤

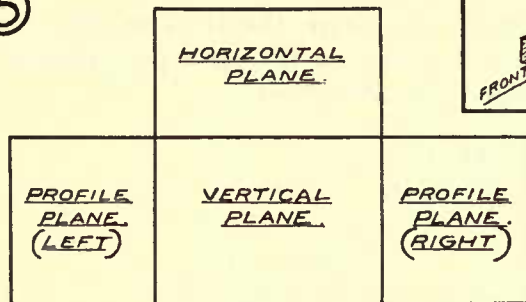

SHOWING PLANES UNFOLDED WHEN LOOKING DIRECTLY AT VERTICAL PLANE.

PICTURE DRAWING.

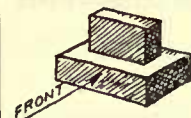

⑥

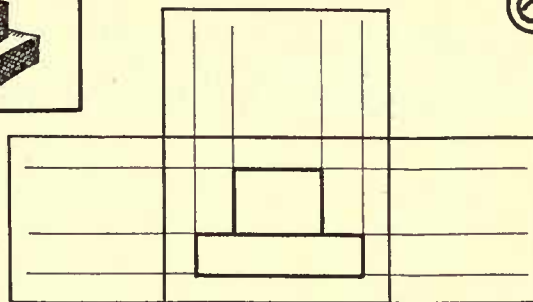

FRONT VIEW OF OBJECT SEEN THROUGH THE VERTICAL PLANE.

⑦

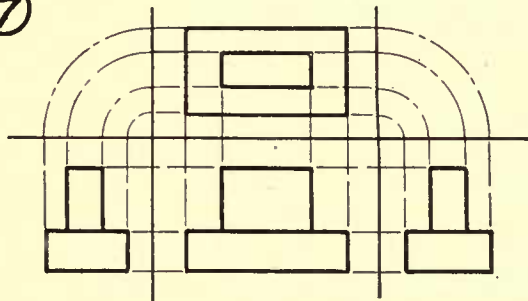

VIEWS OBTAINED BY PROJECTION.

⑧

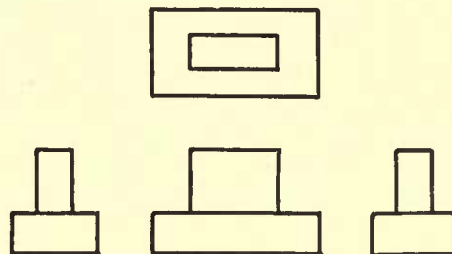

FRONT VIEW, TOP VIEW, RIGHT AND LEFT SIDE VIEWS.

Specification—Plate 17.

In this problem two views of the Triangular Prism are given; the view on the vertical plane and the view on the horizontal plane. Obtain the view on the right profile plane by projection. Show all construction and projection lines. Scale $12''=1'$.

Title:— TRIANGULAR PRISM

SCALE

NAME

DATE

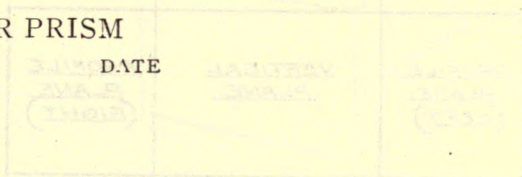
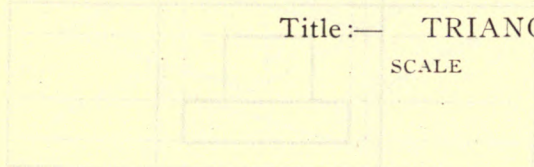

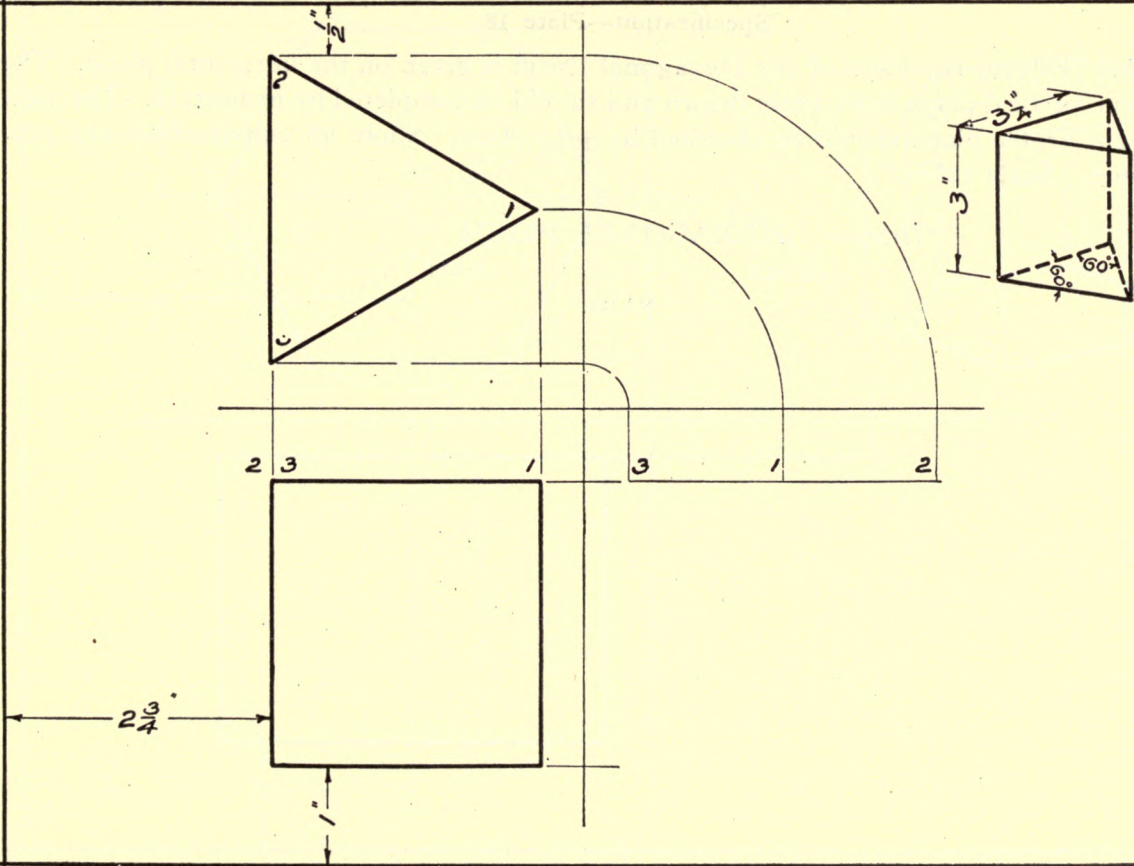

Specification—Plate 18.

In this problem the view of the Hexagonal Prism is given on the horizontal plane. The view on the vertical plane is partially drawn and should be completed by projection. The view on the right profile plane should be obtained by projection. Show all construction and projection lines. Scale 12"=1'.

Title:— HEXAGONAL PRISM

SCALE

DATE

NAME



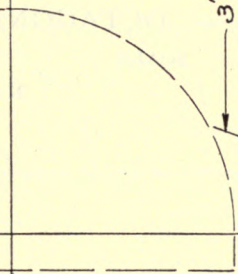
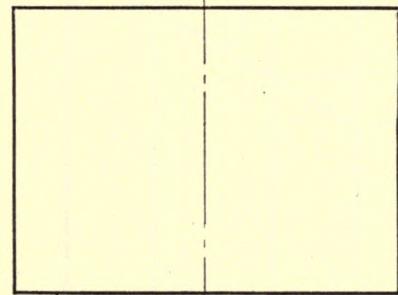
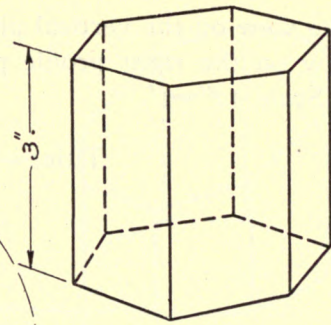
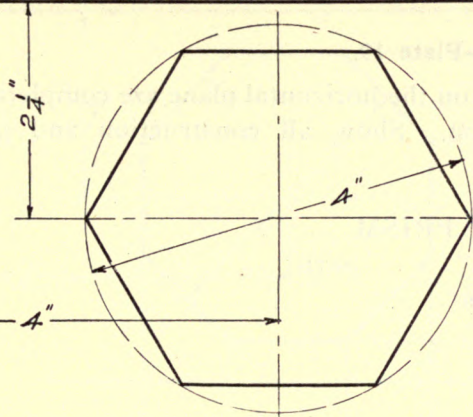

Specification—Plate 19.

The view on the vertical plane and the view on the horizontal plane are complete. Obtain the view on the right profile plane by projection. Show all construction and projection lines. Scale $12''=1'$.

Title:— OCTAGONAL PRISM

SCALE

DATE

NAME



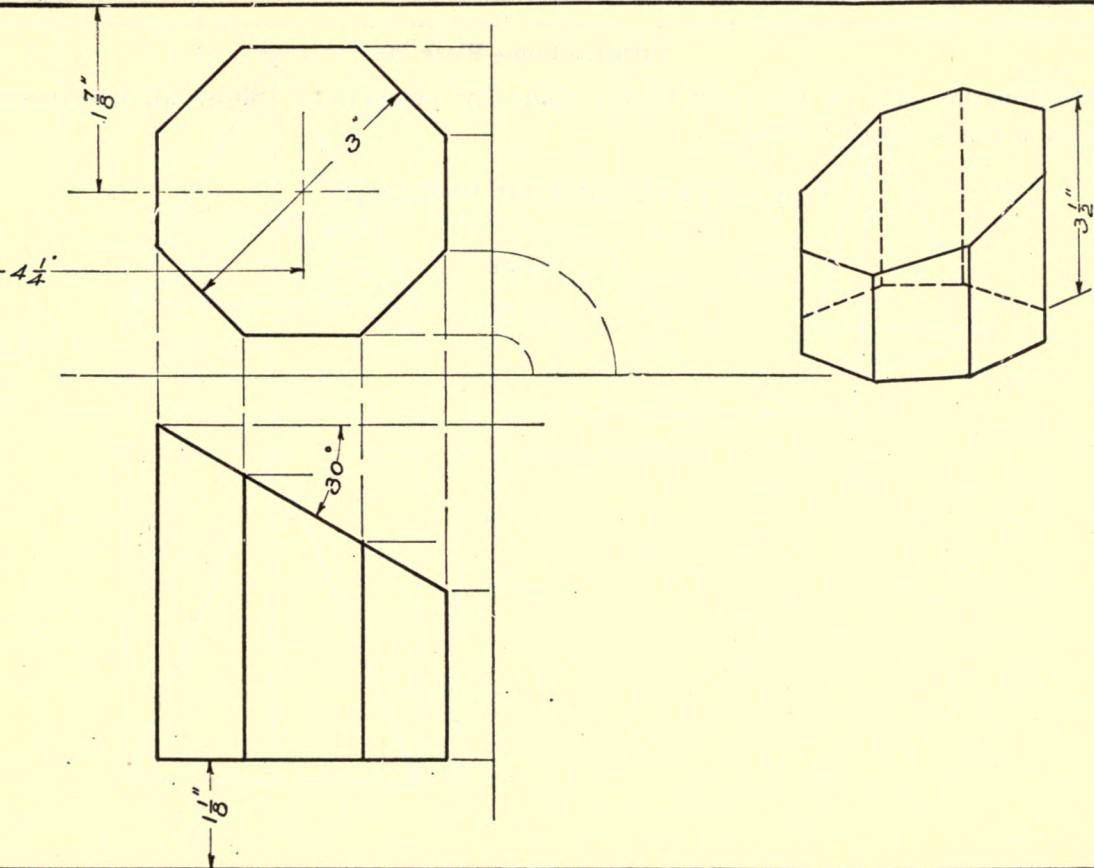

Specification—Plate 20.

Obtain the view on the right profile plane by projection. Show all construction and projection lines. Scale $12''=1'$.

Title:— TRIANGULAR PYRAMID

SCALE

DATE

NAME

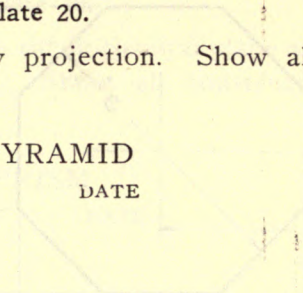

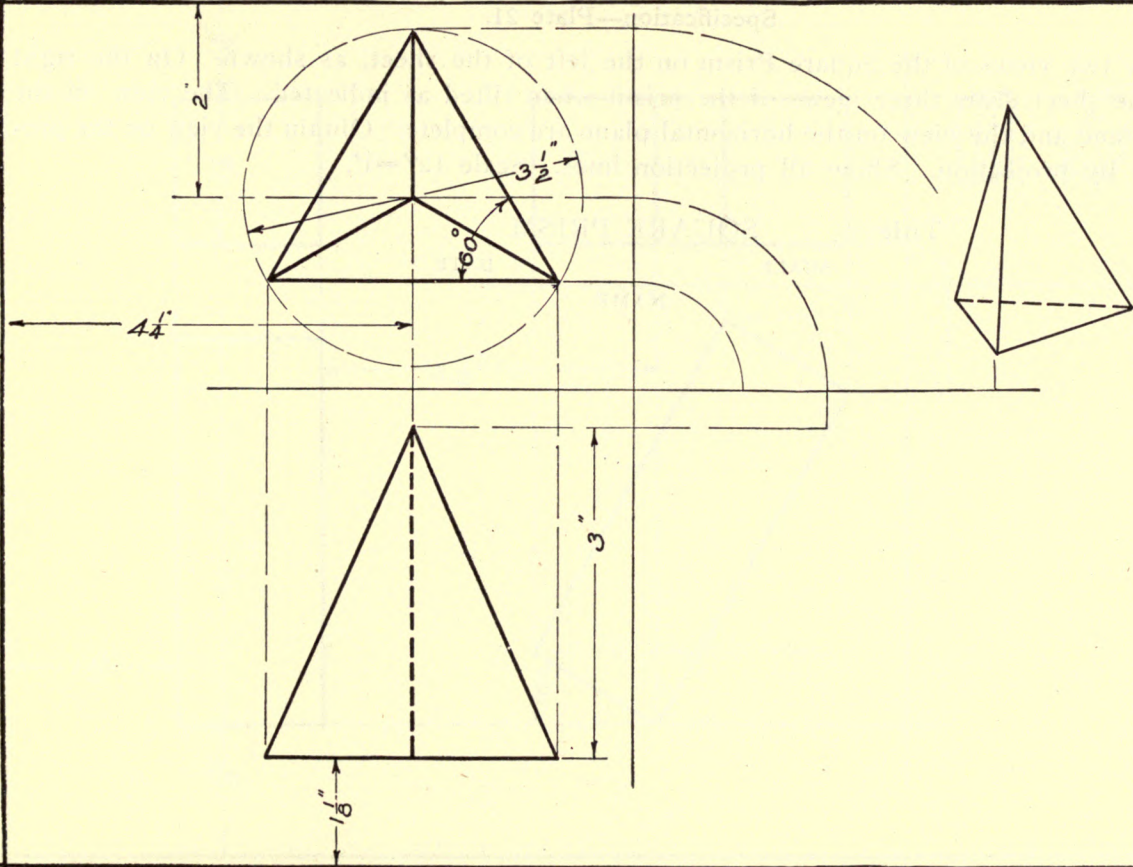

Specification—Plate 21.

Draw two views of the Square Prism on the left of the sheet, as shown. On the right side of the sheet draw three views of the prism when tilted as indicated. The view on the vertical plane and the view on the horizontal plane are complete. Obtain the view on the profile plane by projection. Show all projection lines. Scale 12"=1'.

Title:— SQUARE PRISM

SCALE

DATE

NAME

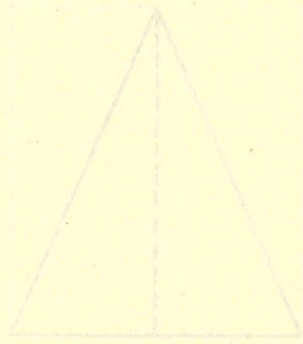
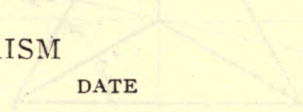
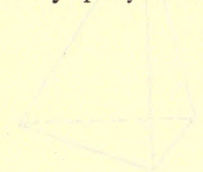
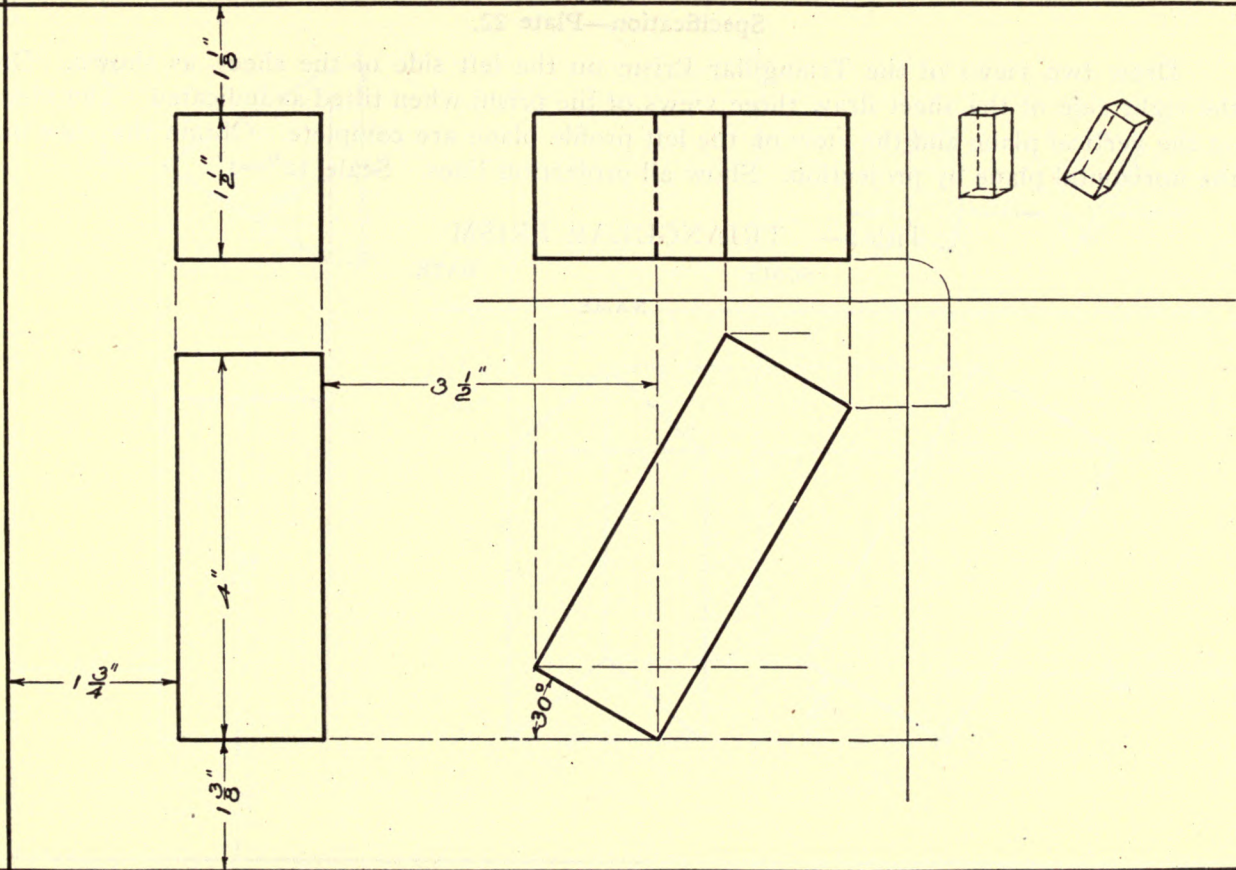

PLATE 21



Specification—Plate 22.

Draw two views of the Triangular Prism on the left side of the sheet, as shown. On the right side of the sheet draw three views of the prism when tilted as indicated. The view on the vertical plane and the view on the left profile plane are complete. Obtain the view on the horizontal plane by projection. Show all projection lines. Scale 12"=1'.

Title:— TRIANGULAR PRISM

SCALE

DATE

NAME



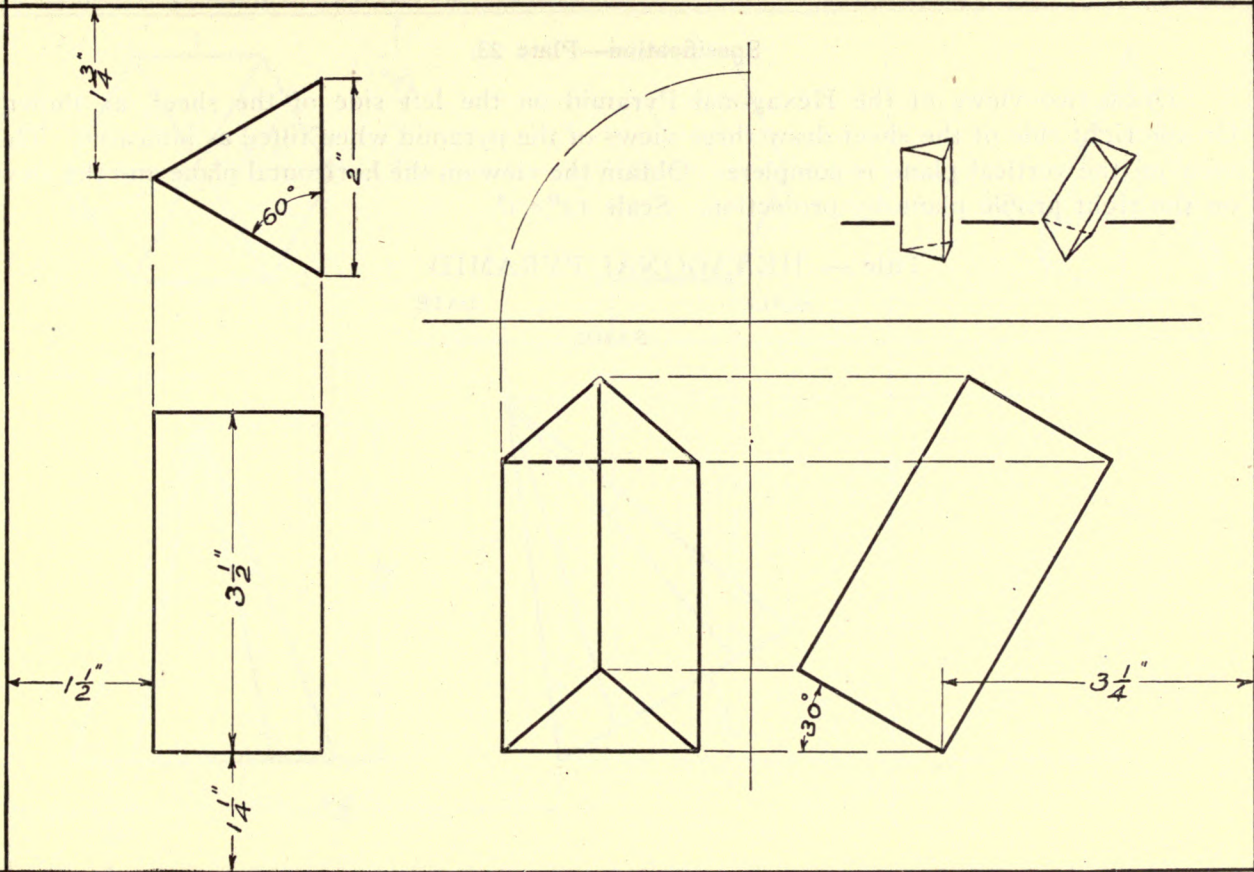

Specification—Plate 23.

Draw two views of the Hexagonal Pyramid on the left side of the sheet, as shown. On the right side of the sheet draw three views of the pyramid when tilted as indicated. The view on the vertical plane is complete. Obtain the view on the horizontal plane and the view on the right profile plane by projection.

Title:— HEXAGONAL PYRAMID

SCALE

DATE

NAME

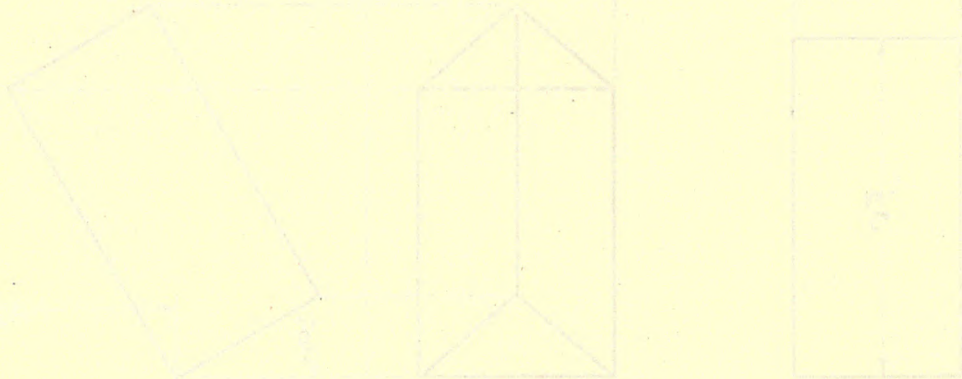

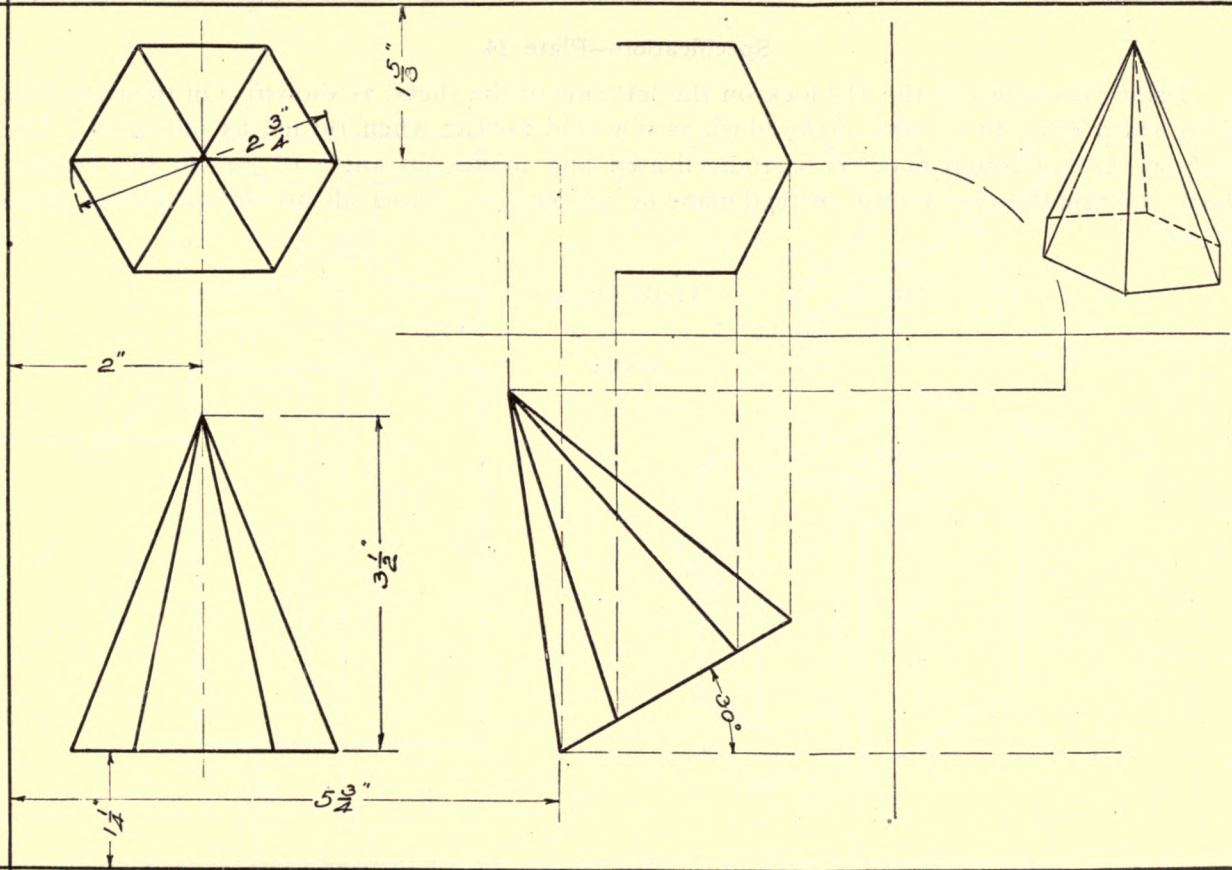

Specification—Plate 24.

Draw two views of the H-block on the left side of the sheet, as shown. On the right side of the sheet draw two views of the block as it would appear when turned as indicated. The view on the horizontal plane is partially drawn and makes an angle of 30° to the vertical plane. Obtain the view on the vertical plane by projection. Show all projection lines. Scale $12''=1'$.

Title:—

H-BLOCK

SCALE

DATE

NAME



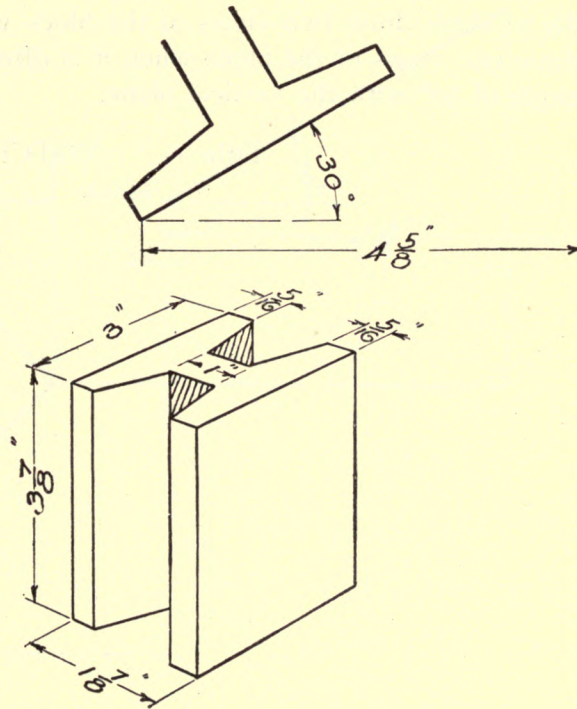
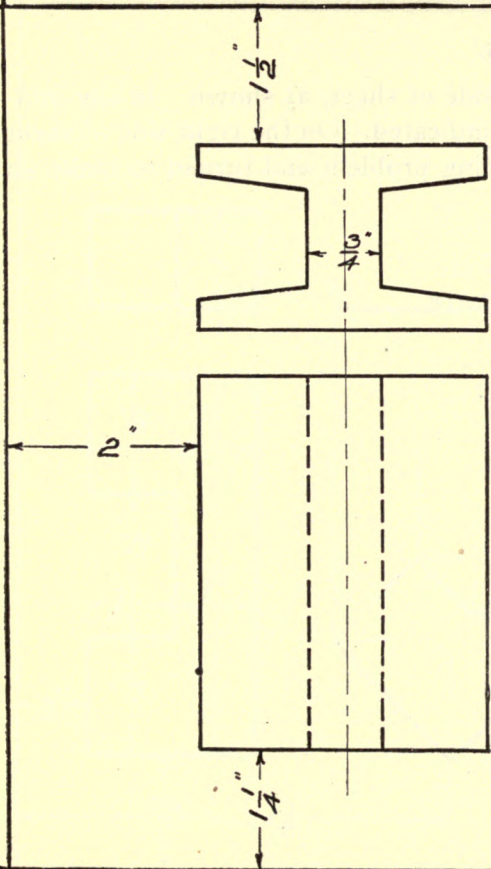

Specification—Plate 25.

Draw two views of the Notched Block on the left side of sheet, as shown. In the middle of sheet draw two views of the block when tilted as indicated. On the right side of sheet draw two views of the block when it is tilted as in preceding problem and turned to make an angle of 30° with the vertical plane.

Title:— NOTCHED BLOCK

SCALE

DATE

NAME

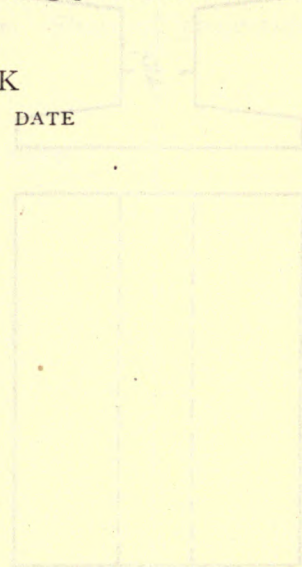

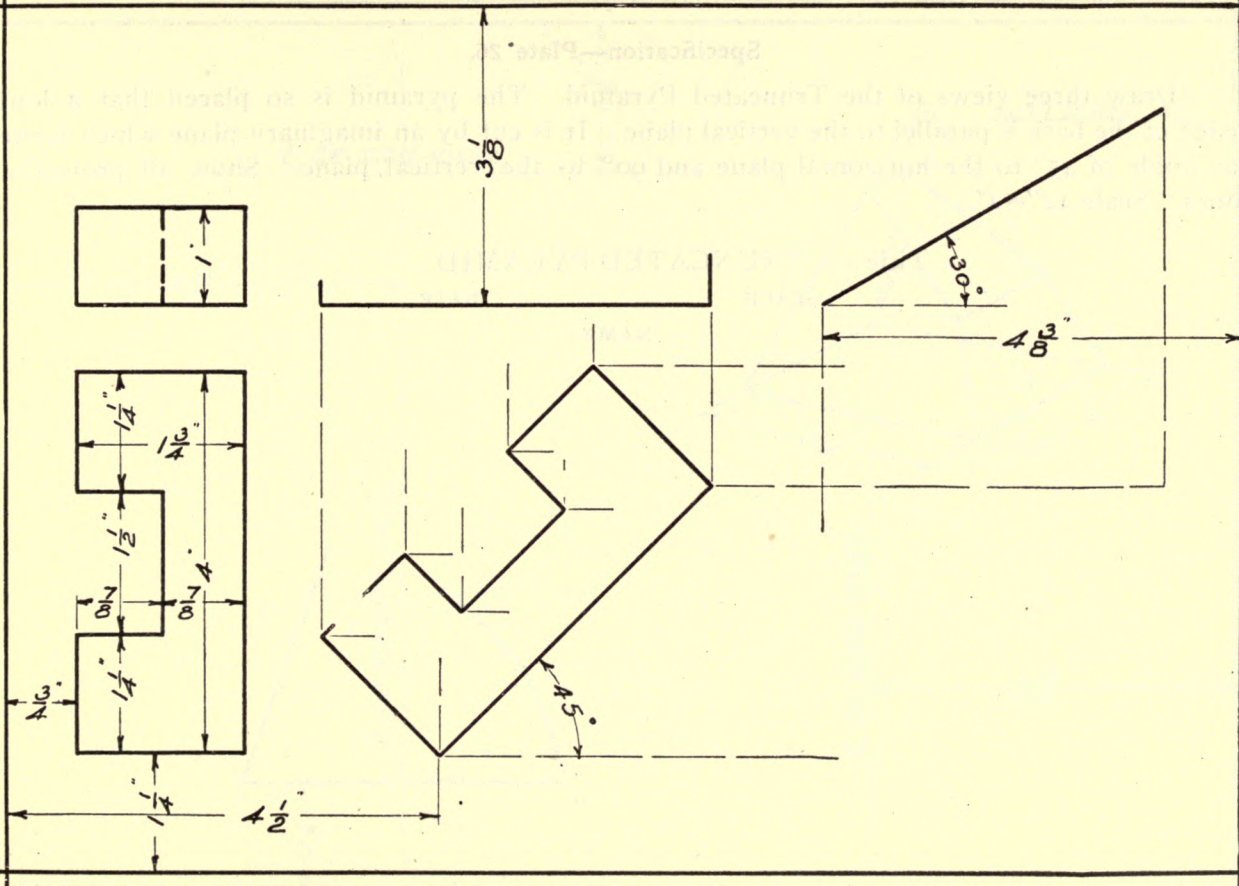

Specification—Plate* 26.

Draw three views of the Truncated Pyramid. The pyramid is so placed that a long edge of the base is parallel to the vertical plane. It is cut by an imaginary plane which forms an angle of 45° to the horizontal plane and 90° to the vertical plane. Show all projection lines. Scale $12''=1'$.

Title:— TRUNCATED PYRAMID

SCALE

DATE

NAME



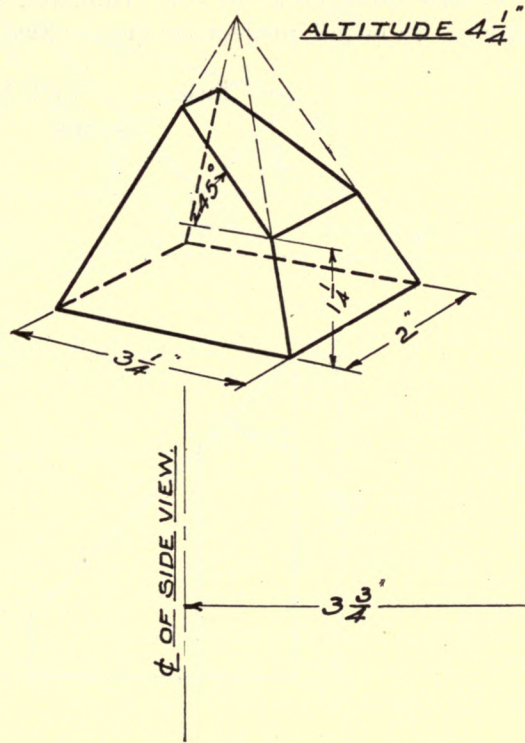
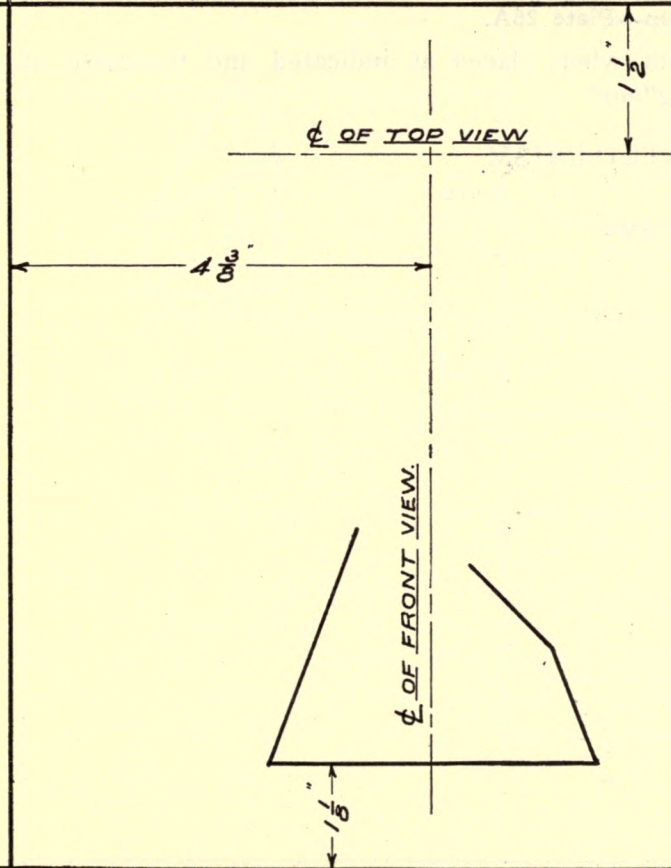

Specification—Plate 26A.

Draw three views of the Truncated Prism when placed as indicated and truncated as shown. Show all projection lines. Scale 12"=1'.

Title:— TRUNCATED PRISM

SCALE

DATE

NAME

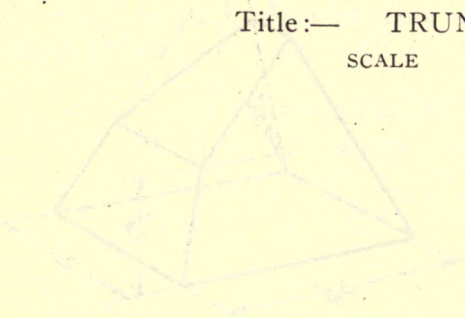
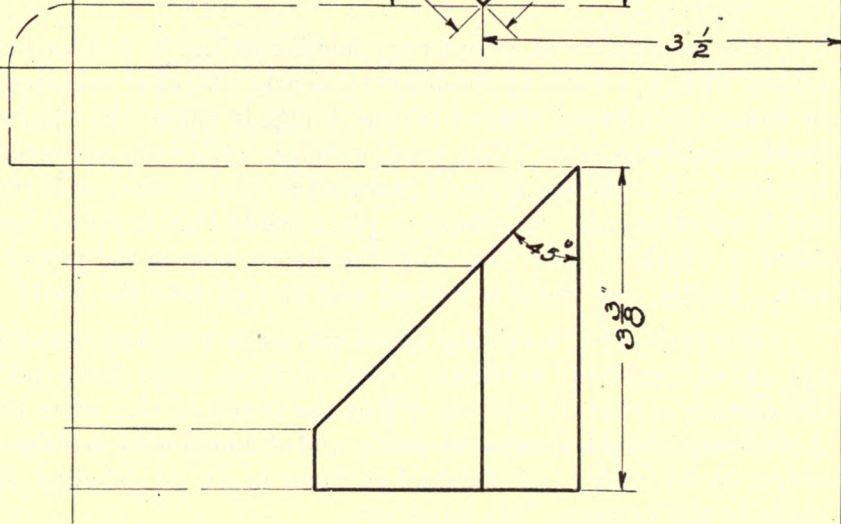
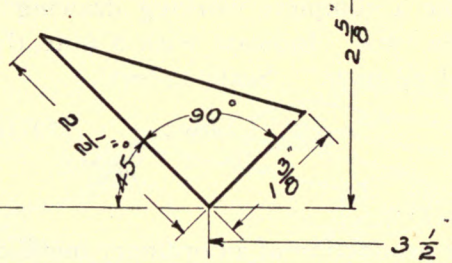
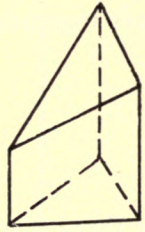

PLATE 26A



Specification—Plate 27.

Make a complete working drawing of the Tool-post Slide, showing the front, top and right-side view. Indicate with a note that the piece is to be made of cast iron and is to be "finished all over." Scale 12"=1'.

Title:— TOOL-POST SLIDE

SCALE

DATE

NAME

The production of an ordinary metal casting, as iron or brass, involves three distinct operations. First, a form or model very nearly like that required in the casting is made of wood or some other easily shaped material, and is called the "pattern." Next, with this pattern a mold is made in sand. The sand, which is especially prepared for the purpose, is called mold-sand. It contains a small percentage of clay and will retain its shape after the pattern has been removed. It is held in place while the mold is being made by a box, or frame called a "flask." The flask also facilitates making the proper cavity in the sand with the pattern. Lastly, the metal is melted and poured into the mold.

The surfaces of a casting which are made true and smooth by cutting them on a machine, are called "finished" surfaces. Such surfaces must have added metal allowed on them in the casting so that the casting will be the required size after the surfaces have been machined. A drawing should always be made and dimensioned to the required machined size of the object to be made. All finished surfaces must be labelled so that due allowances will be made in the pattern. See page 195.

1. How are metal castings made?
2. What is meant by "finish" in a working drawing?
3. What is meant by "finish all over"?

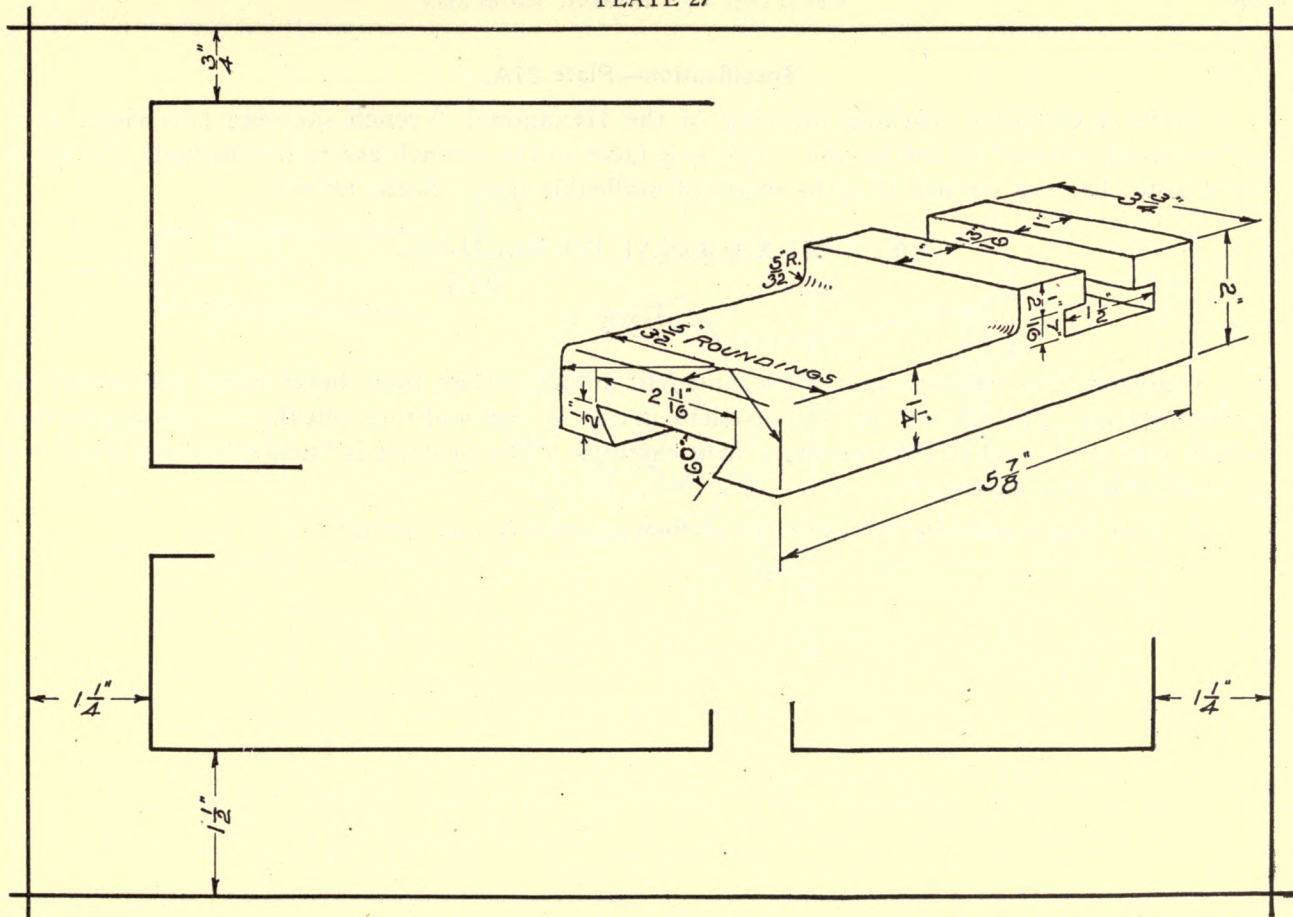

Specification—Plate 27A.

Make a complete working drawing of the Hexagonal Wrench showing two views and a “revolved section” of the handle. The two faces of the wrench are to be finished. Indicate by a note that the wrench is to be made of malleable iron. Scale 12"=1'.

Title:— HEXAGONAL WRENCH

SCALE

DATE

NAME

Ordinary iron castings are brittle and will break rather than bend when put under a severe strain. The wrench in this problem is cast of iron and then put thru a baking process which makes it tougher than ordinary iron castings. The product is “malleable cast iron” or a “malleable iron casting.”

1. How does a malleable iron casting differ from an ordinary iron casting?

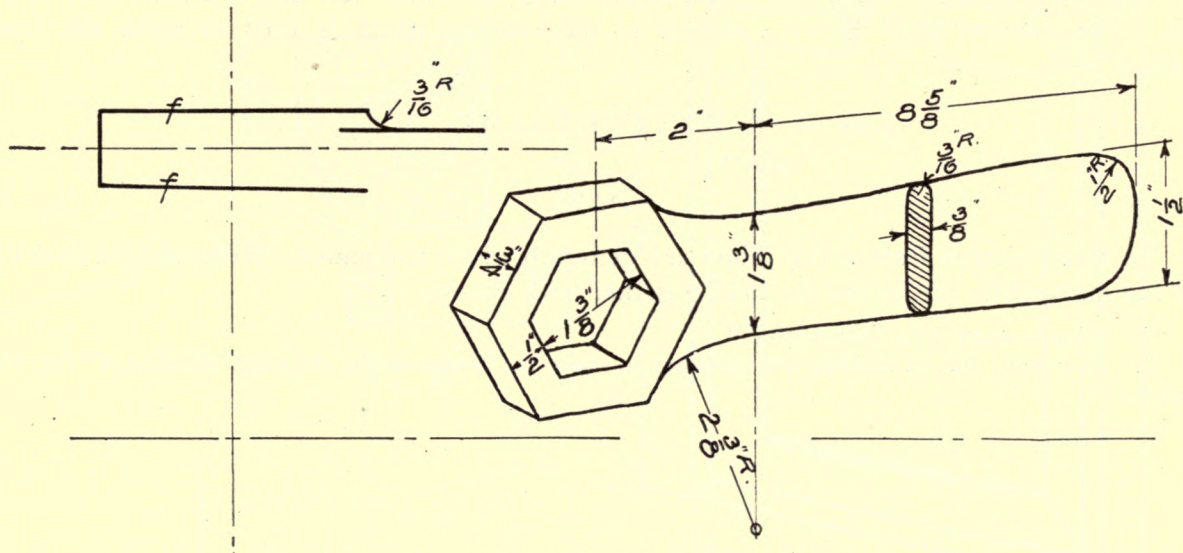

Specification—Plate 28.

Make a drawing of the Picture Frame, showing the front view and the side view in section. The full-size detail shows a section of the molding which is used to make the frame. Scale 6"=1'.

Title:— PICTURE FRAME

SCALE

DATE

NAME

In small picture frames the joints are generally glued and nailed. Holes should be drilled for the nails while the pieces are held together with clamps.

1. What is meant by a "mitre-joint"?
2. How many feet of molding are necessary to make the frame in the drawing, allowing 4" for waste stock?

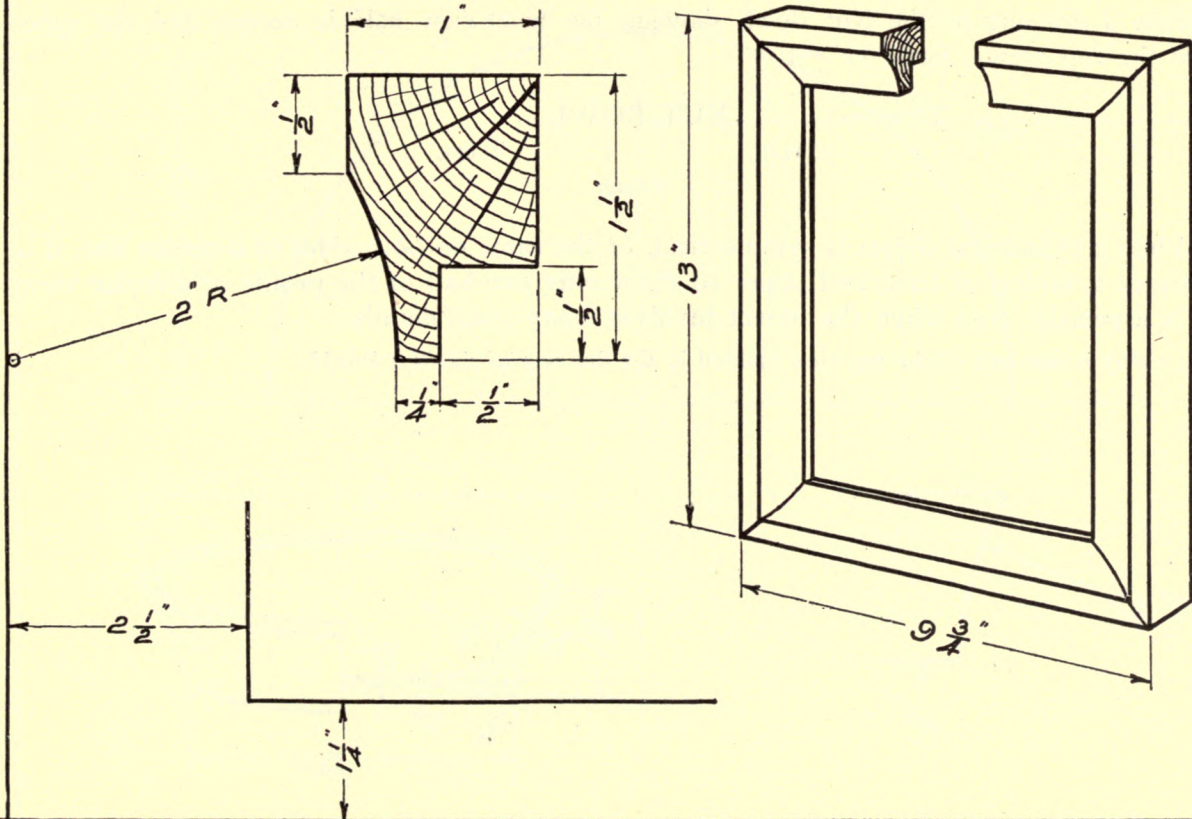

Specification—Plate 28A.

Make a drawing of the Nut Bowl, showing the front-view half in section and the upper half of the top view. Scale 12"=1'.

Title:—

NUT BOWL

SCALE

DATE

NAME

When a cylindrical object is symmetrical, or the same on both sides of a center line, it is sometimes a saving of time and paper to draw only one-half of the profile or circular view. This is especially true when the object involves many small details.

1. Why is one-half of the top view omitted in the drawing of the Nut Bowl?

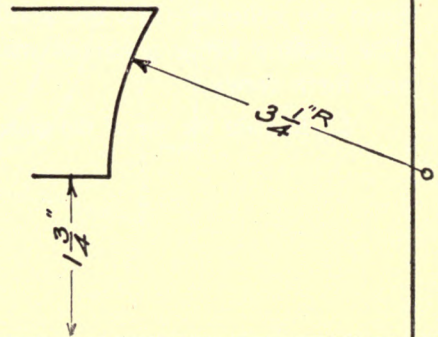
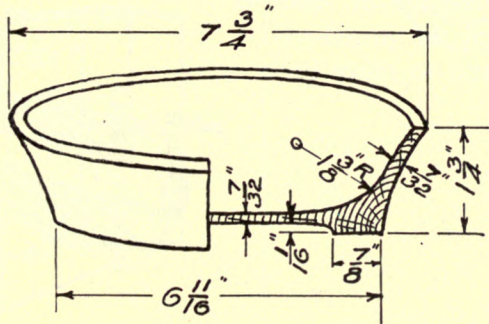
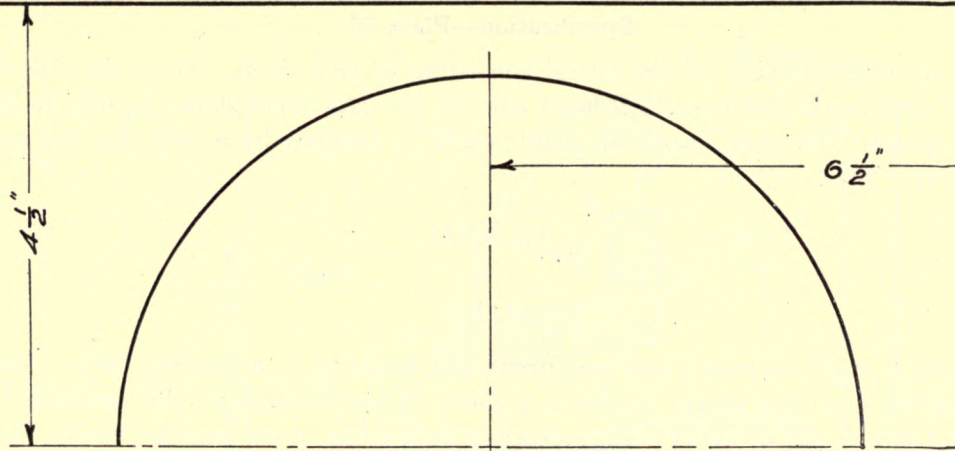

Specification—Plate 29.

Make a working drawing of the Gland consisting of two views. Show the side-view half in section. The drawing in the lower left-hand part of the data sheet shows a full-size detail of the bevels on the gland. The total length of gland is $2\frac{3}{4}$ ". Indicate by a note that the piece is to be finished all over. Scale $12''=1'$.

Title:— GLAND

SCALE

DATE

NAME

The gland is used to retain and compress the packing in a stuffing box. (See illustration.) A stuffing box in a steam engine is a piece of mechanism at the opening thru which the piston-rod enters the cylinder. By screwing down the nuts on the studs, the gland is forced deeper into the stuffing box and compresses the packing against the piston-rod and the walls of the stuffing box, thereby preventing leakage of steam from the cylinder thru the stuffing box and around the piston-rod. The packing being a fibrous material, allows the rod to move back and forth freely.

1. Explain the use of the gland.

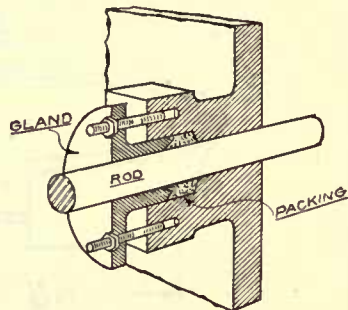

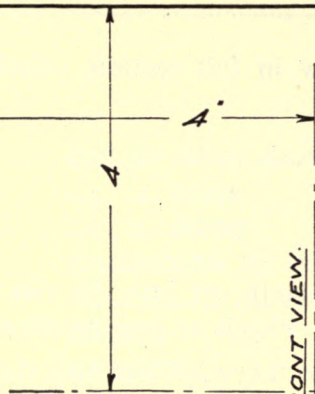

CL OF FRONT VIEW.

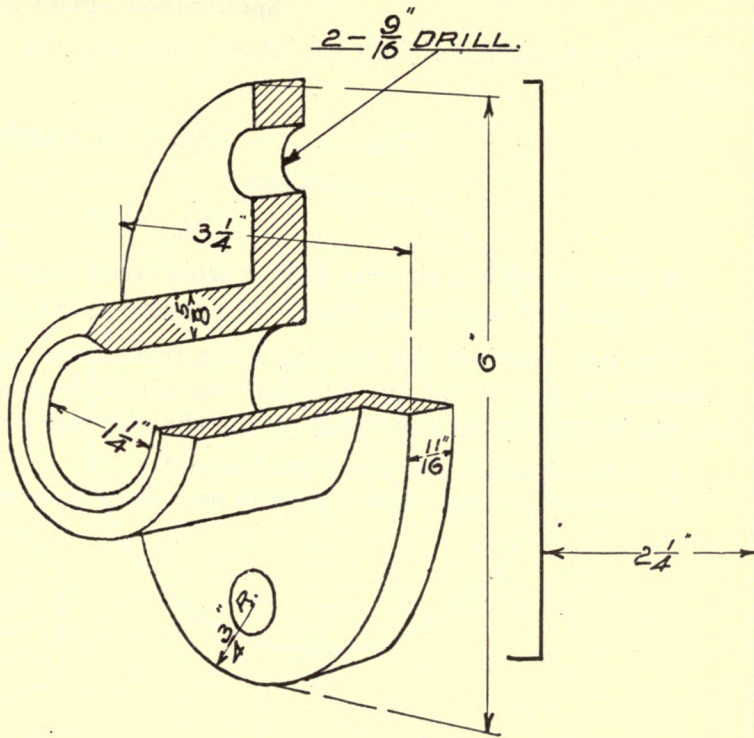
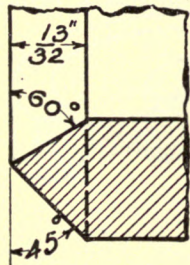

Specification—Plate 29A.

Make a drawing of the Gear Blank, showing the side view in full section. Scale 12" = 1".

Title:— GEAR BLANK

SCALE

DATE

NAME

A gear wheel is a circular disk or wheel with cogs or gear teeth cut into the rim. It is used to transmit motion by means of engaging with other gear wheels or gear-toothed parts.

The gear blank in the drawing has a rectangular groove, or "keyway" cut into the bore. A similar keyway is cut into the shaft on which the gear is mounted. A "key" which is fitted into the keyways, locks the gear on the shaft so that gear and shaft revolve together.

1. Where have you seen a gear wheel in use?
2. How can a wheel which is mounted on a shaft be fastened to the shaft so that it revolves with it?

PLATE 29A

DIA. OF GEAR BLANK 4.788"

" " HUB $1 \frac{3}{4}$ "

" " BORE $\frac{7}{8}$ "

THICKNESS OF WEB $\frac{7}{16}$ "

" " RIM $\frac{7}{16}$ "

FACE $1 \frac{1}{16}$ "

KEYWAY $\frac{3}{16}$ " x $\frac{3}{32}$ "

FILLETS $\frac{1}{8}$ " R.

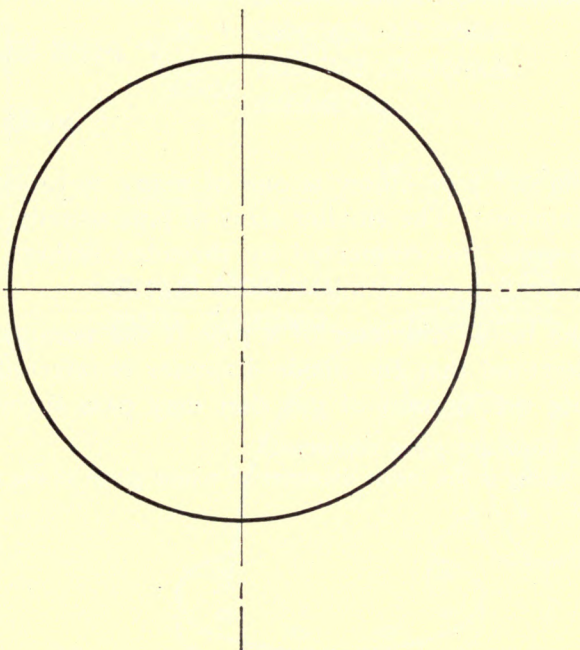
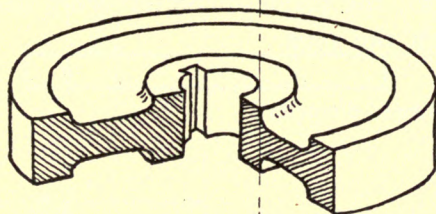

Specification—Plate 30.

Make a working drawing of the 5" Pipe Elbow, showing the front and left-side view. Show a partial section in the side view as suggested in the picture drawing. It is unnecessary to show invisible lines representing the drilled holes. Scale 12"=1'.

Title:— 5" PIPE ELBOW

SCALE

DATE

NAME

The 90° pipe elbow is one of many so-called "pipe fittings" which are used to join or connect pipes. The smaller sizes of pipe usually have screwed joints. The pipe is threaded on the ends and connected by threaded fittings. The larger sizes of pipe are usually connected by flanged fittings bolted together.

The inside diameter of a pipe is the nominal diameter. In speaking of a 1" gas pipe, it is understood that the inside diameter is referred to; the inside diameter being necessary to compute the amount of gas that may pass through the pipe.

1. How are pipes connected?
2. Why is the inside diameter of a pipe given as the nominal diameter?

- A = SIZE OF PIPE 5"
 - B = BOLT HOLE CIRCLES 8 $\frac{1}{4}$ "
 - C = THICKNESS OF PIPE $\frac{1}{2}$ "
 - T = " " FLANGE 1 $\frac{15}{16}$ "
 - E = CENTER TO FACE 7 $\frac{1}{2}$ "
 - F = DIA. OF FLANGE 10"
- FILLETS 3" R.

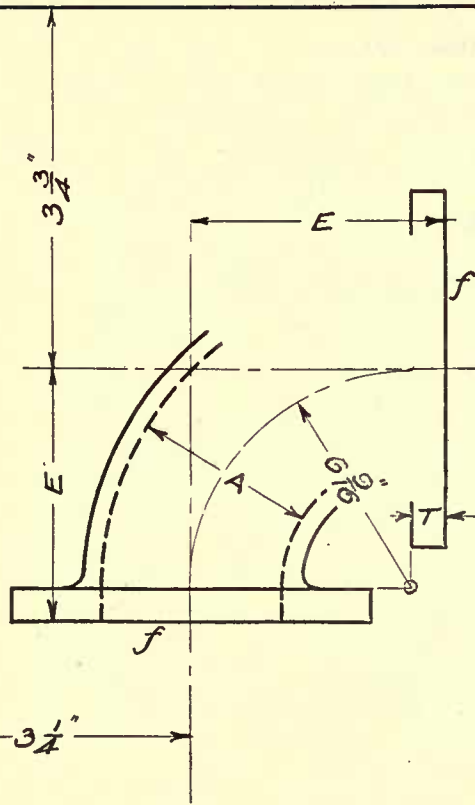

8 - $\frac{7}{8}$ " Drill in both flanges.

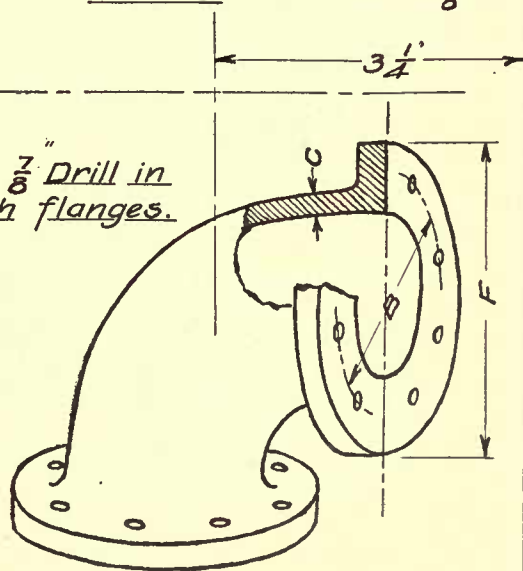

Specification Plate 30A.

Make a drawing of the Chain as indicated. Scale 12"=1'.

Title:— CHAIN

SCALE

DATE

NAME

The area of a circle = radius x radius x 3.1416.

The volume of a cylinder = area x length.

1. Compute the volume of a single link of the chain.

PLATE 30A

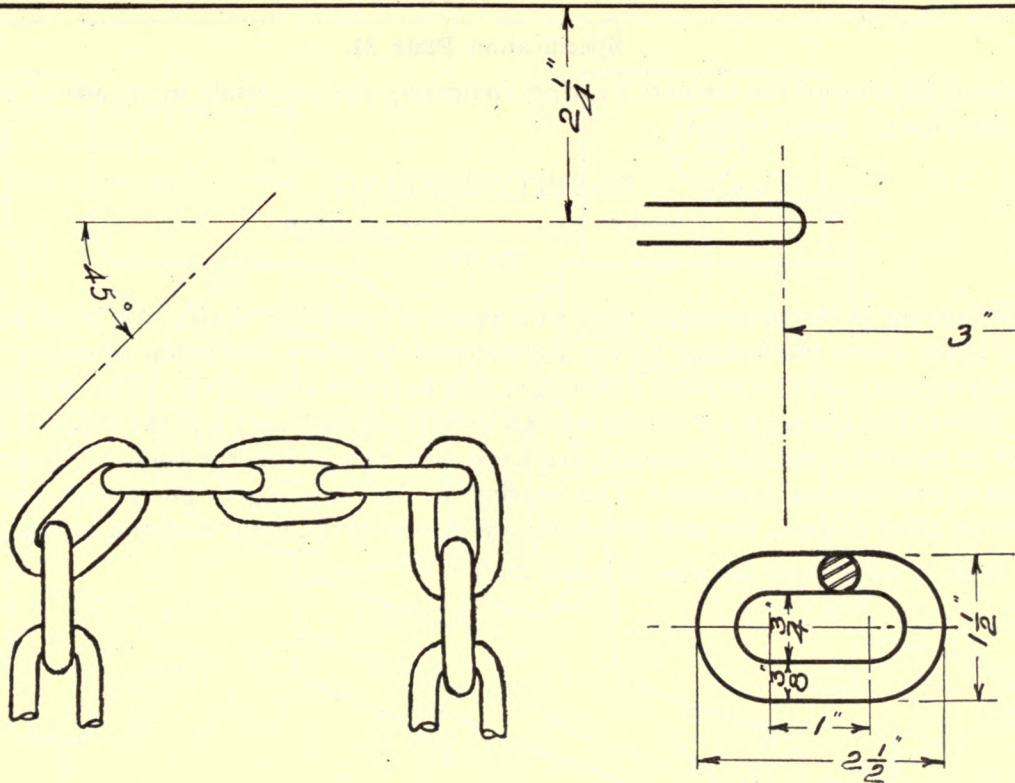

Specification Plate 31.

Make a drawing of the Babbitt Bearing, indicating the materials by means of a section in one of the views. Scale 12"=1'.

Title:— BABBITT BEARING

SCALE

DATE

NAME

The bearing in the drawing is used to support a revolving shaft. As in all machines or machine parts where motion and power are transmitted, there is friction between the surface of the moving part and the surface of the part that bears or supports it. This friction causes a loss of power, and causes wear on the surfaces of the moving part and the support, or bearing. In order to minimize friction, bearings are lined with one of several kinds of "bearing metal" which have anti-friction qualities. The bearing in the drawing is lined with babbitt metal which is an alloy of lead, tin and antimony and is one of the most common of bearing metals.

1. What is babbitt metal and what is it used for?

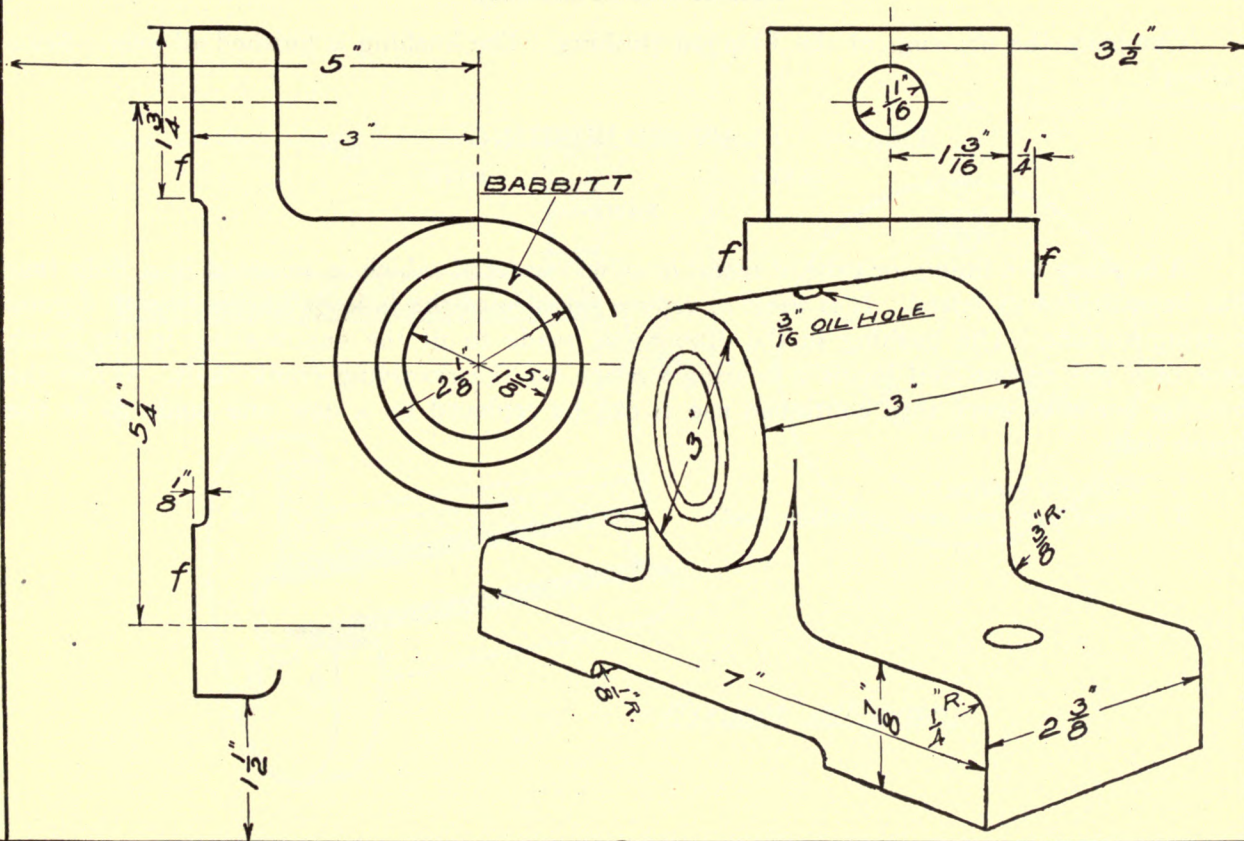

Specification—Plate 31A.

Complete the drawing of the Flanged Bushing. The bushing is finished all over. Scale 12"=1'.

Title:— FLANGED BUSHING

SCALE

DATE

NAME

A bushing is a lining, or tube of metal or other material which is inserted in a hole that has been drilled or bored. It is used to reduce the size of the hole or to line it with a good bearing surface. The bushing in the drawing is made to fit the end bearing in the crank case of a gas engine and forms a bearing surface for the revolving crank shaft. When the bearing becomes worn thru continued use, it can be replaced by a new one made to fit the crank shaft.

1. What is a bushing?
2. Where have you seen a bushing used?

PLATE 31A

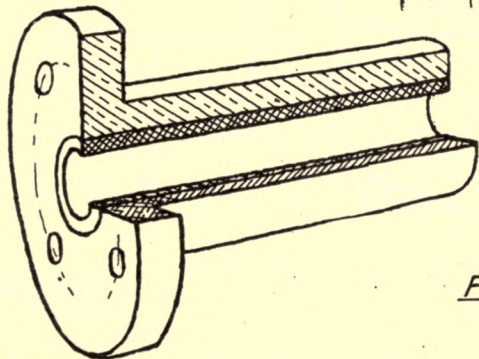
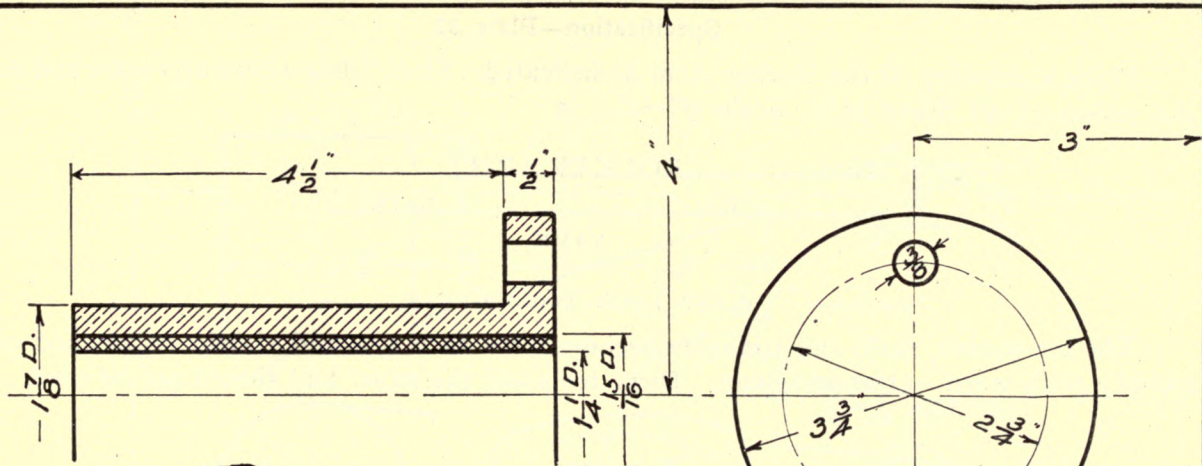

Finish all over.

Specification—Plate 32.

Make a drawing of the Rocker Arm as indicated. Place fillets where necessary and make the radius of all fillets $\frac{1}{8}$ ". Scale 9"=1'

Title:— ROCKER ARM

SCALE

DATE

NAME

KEEP YOUR TOOLS CLEAN.

The tee-square, scale and triangles become dirty thru use and should be cleaned occasionally with warm water and soap. Dirty tools soil the paper and should not be used.

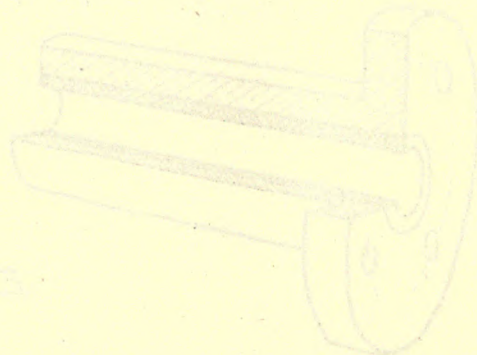
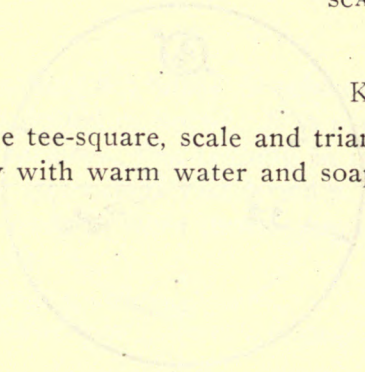

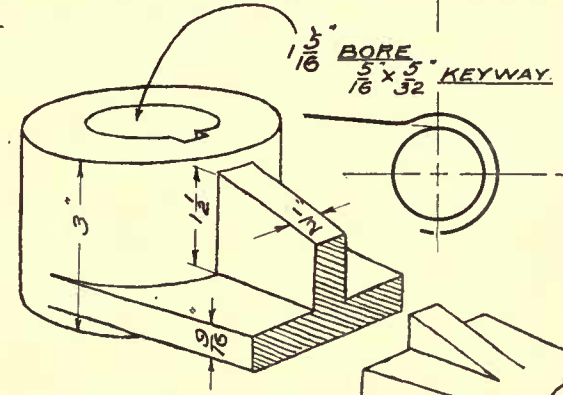
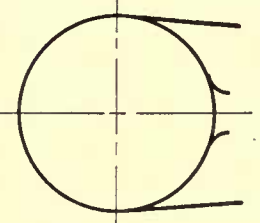
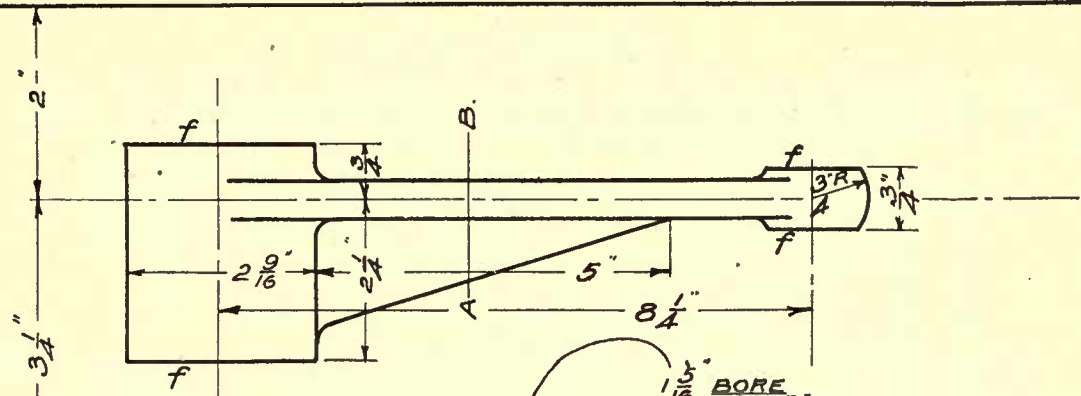

$1\frac{5}{16}$ " BORE
 5×5 " KEYWAY
 $1/16 \times 3/32$

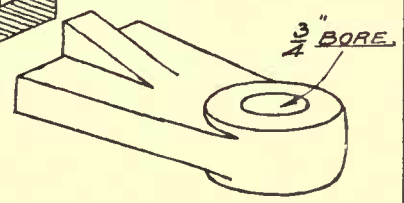

SHOW SECTION
ON A-B HERE.

Specification—Plate 32A.

Make a drawing of the Bell-crank Lever as indicated. All fillets $\frac{1}{4}$ " unless otherwise specified. Diameter of large hub $3\frac{1}{4}$ ". Diameter of small hubs $2\frac{1}{4}$ ". Scale 6"=1'.

Title:— BELL-CRANK LEVER

SCALE

DATE

NAME

KEEP YOUR PENCIL POINTS SHARPENED.

Accurate and neatly executed drawings require well sharpened lead points. The compass lead should be sharpened to a chisel point similar to the chisel point on a pencil.

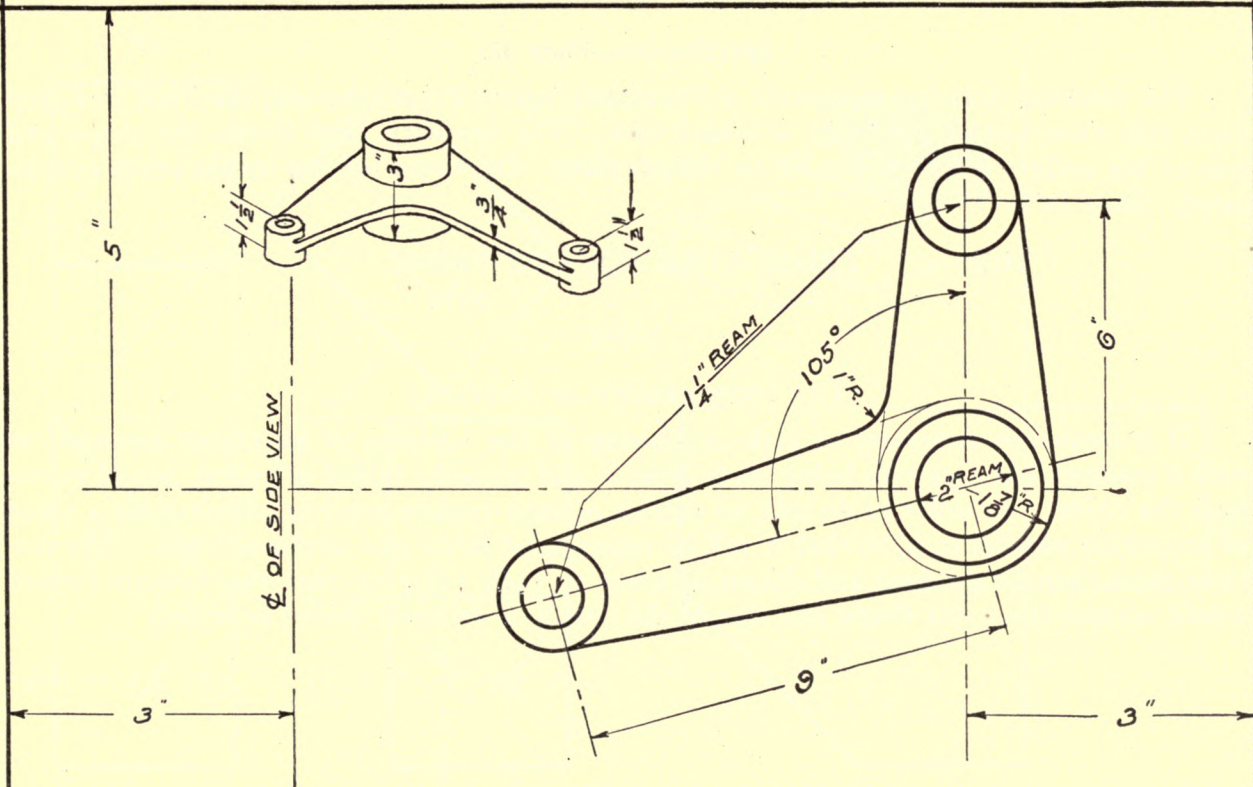

Specification—Plate 33.

The working drawing represents a Truncated Square Prism, showing the front view, top view, side view and an auxiliary, or added view. The auxiliary view shows the shape and size of the surface which is cut by an oblique plane. Develop a pattern for the prism as indicated. Scale 12"=1'.

Title:— TRUNCATED SQUARE PRISM

SCALE

DATE

NAME

THE DEVELOPMENT OF SURFACES.

It is frequently necessary to make a drawing of the surfaces of an object arranged in such a manner that a pattern being made from it and properly folded or rolled, would reproduce the object. In order to do this, an outline of each surface must be obtained on a plane of projection parallel to it, so that it will be represented in its true shape and size. The surfaces must then be grouped and drawn adjacent to each other so that the pattern formed would assume the exact shape and size of the object, if properly folded or rolled.

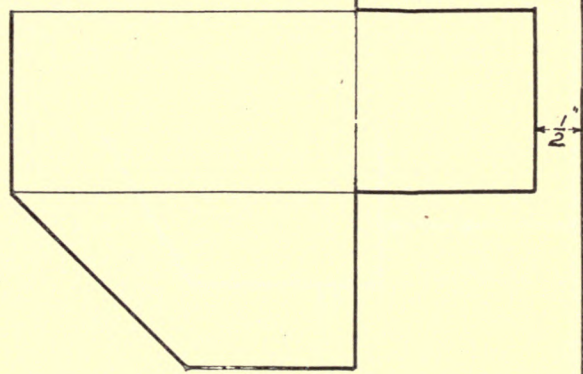
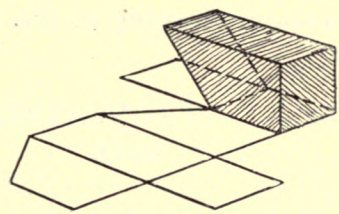
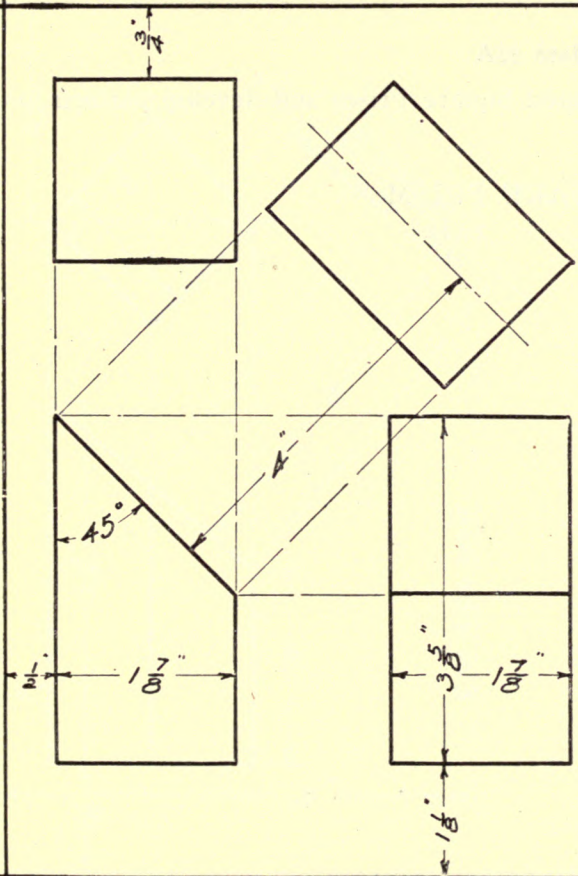

Specification—Plate 33A.

Complete the working drawing of the Truncated Square Prism and develop pattern for same. Scale 12"=1'.

Title:— TRUNCATED SQUARE PRISM
SCALE DATE
NAME

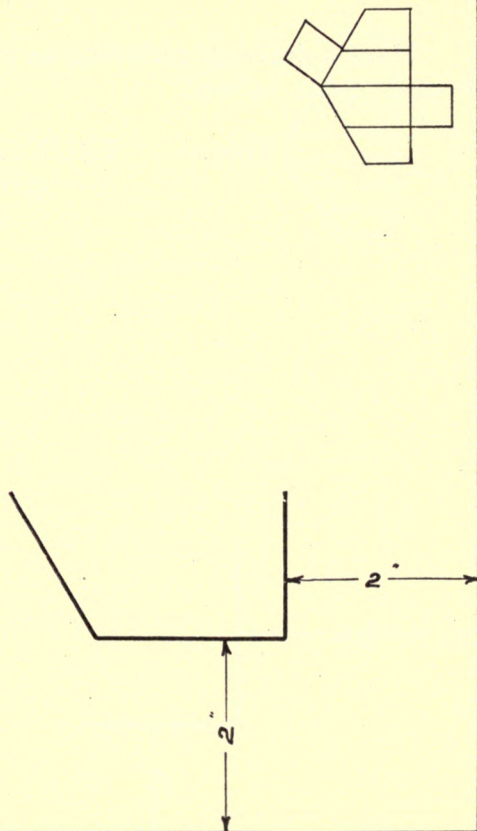
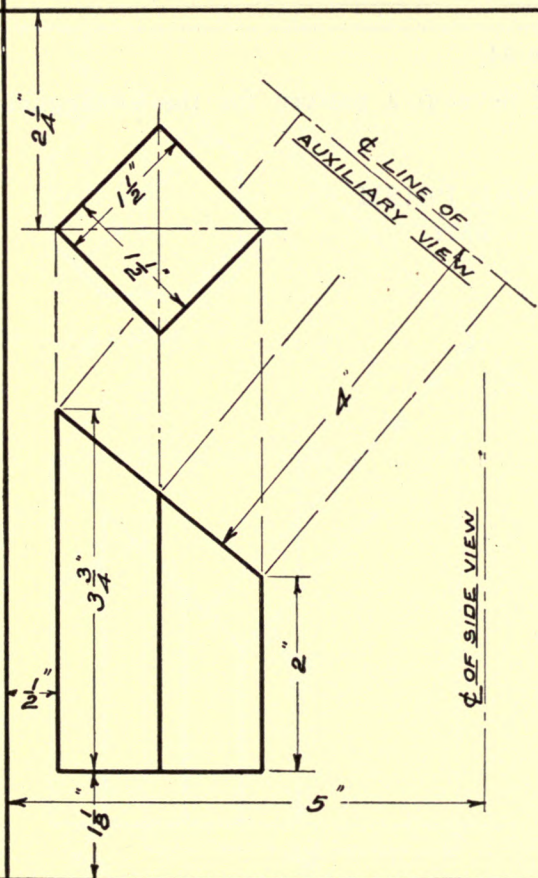

Specification—Plate 34.

Make a drawing, including an auxiliary view, and develop a pattern for the Octagonal Prism. Scale 12"=1'.

Title:— TRUNCATED OCTAGONAL PRISM

SCALE

DATE

NAME



PLATE 34

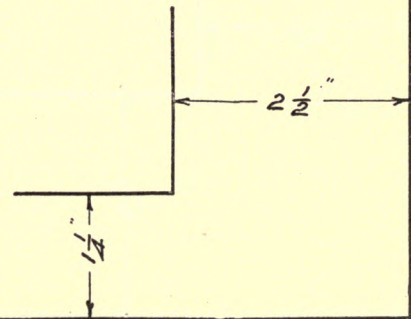
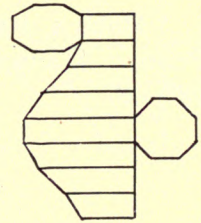
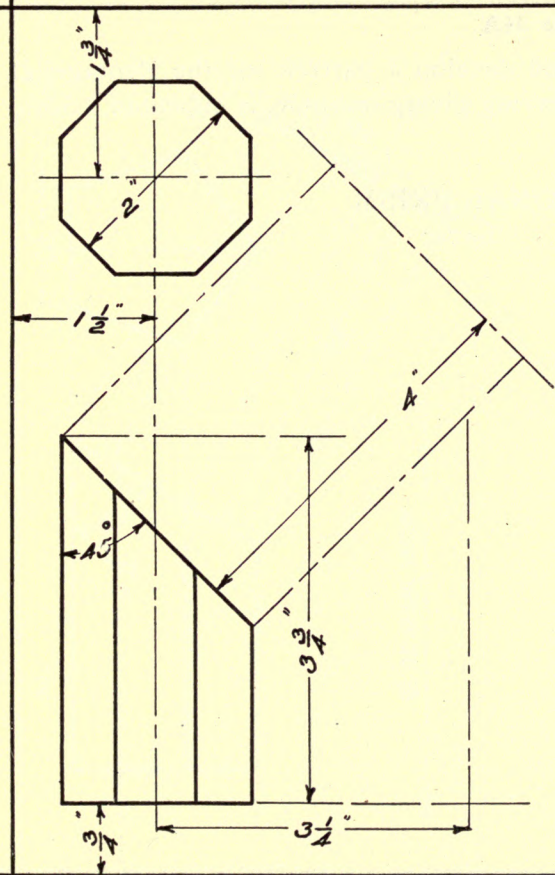

Specification—Plate 34A.

Make a drawing, including an auxiliary view, and develop a pattern for the Pentagonal Prism. A simple method of drawing a pentagon, having giving one side, is indicated. Scale $12''=1'$.

Title:— TRUNCATED PENTAGONAL PRISM

SCALE

DATE

NAME

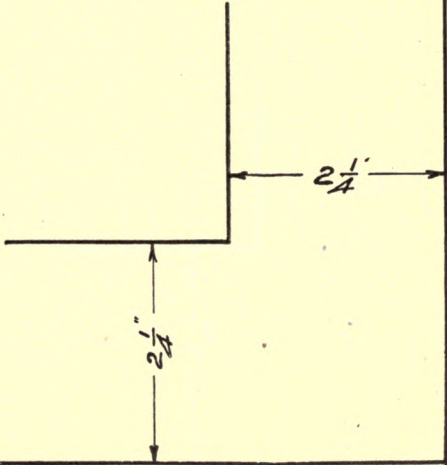
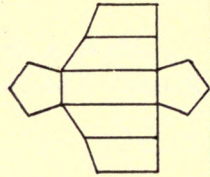
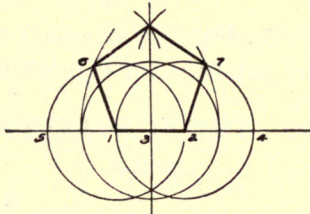
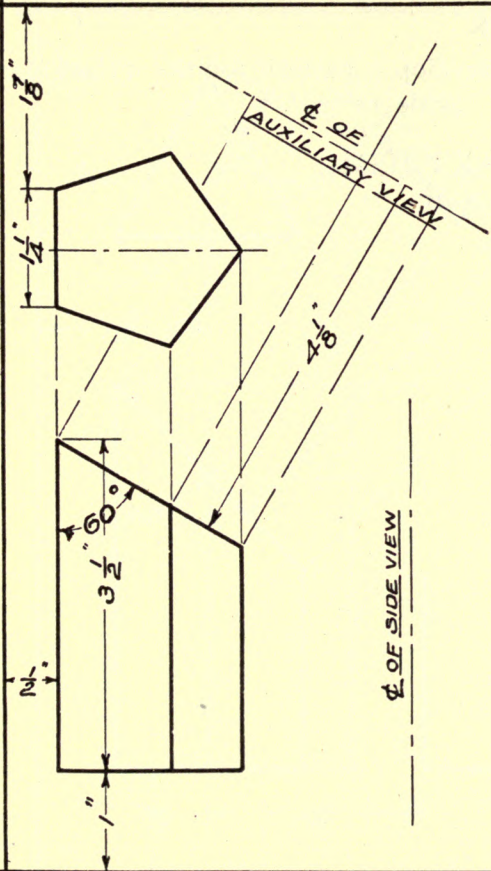

Specification—Plate 35.

Make a drawing, including an auxiliary view, and develop a pattern for the Triangular Prism. The base of the prism is an equilateral triangle. Scale $12''=1'$.

Title:— TRUNCATED TRIANGULAR PRISM

SCALE

DATE

NAME



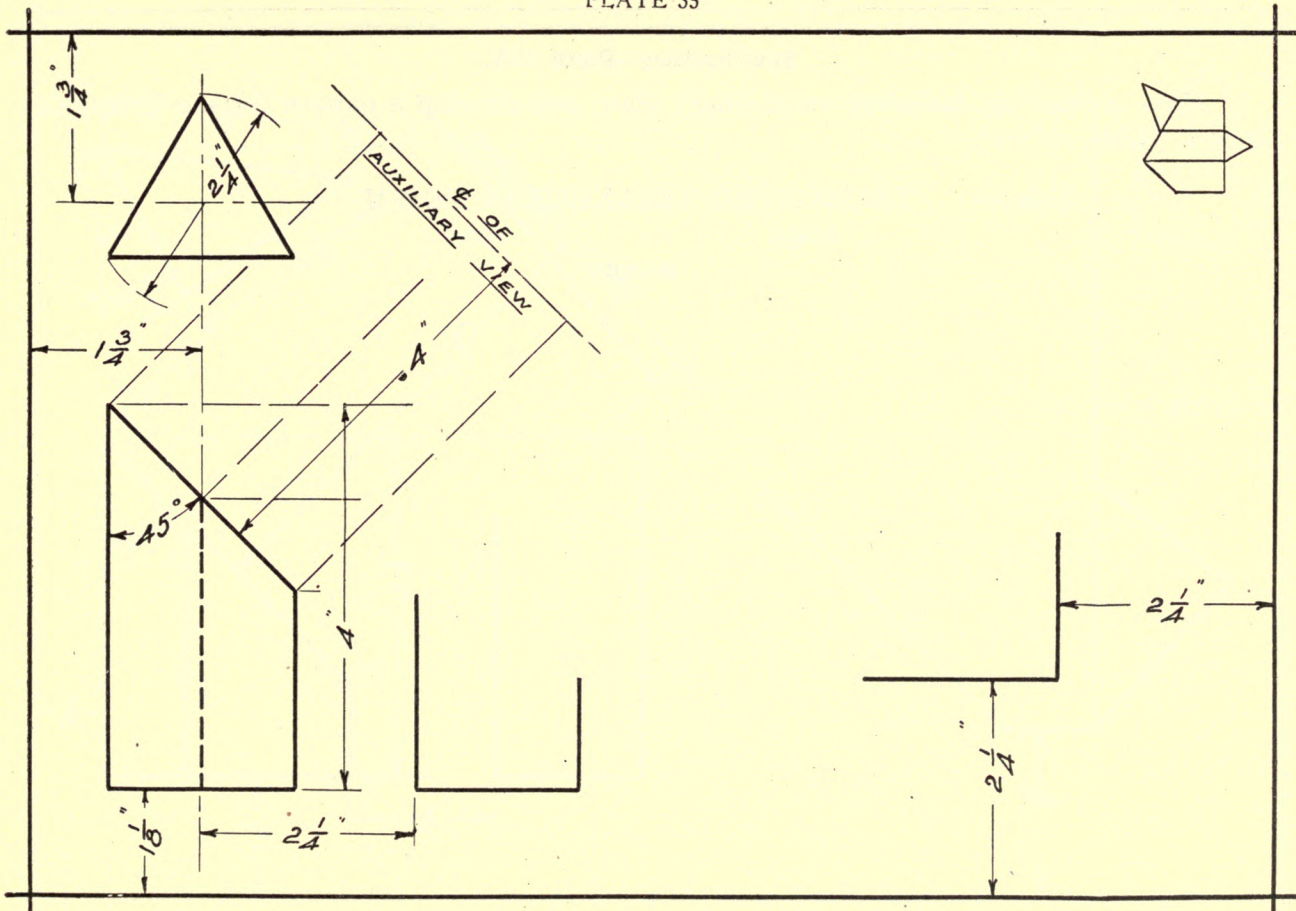

Specification—Plate 35A.

Make a drawing, including an auxiliary view, and develop a pattern for the Triangular Prism. Scale 12"=1'.

Title:— TRUNCATED TRIANGULAR PRISM

SCALE

DATE

NAME

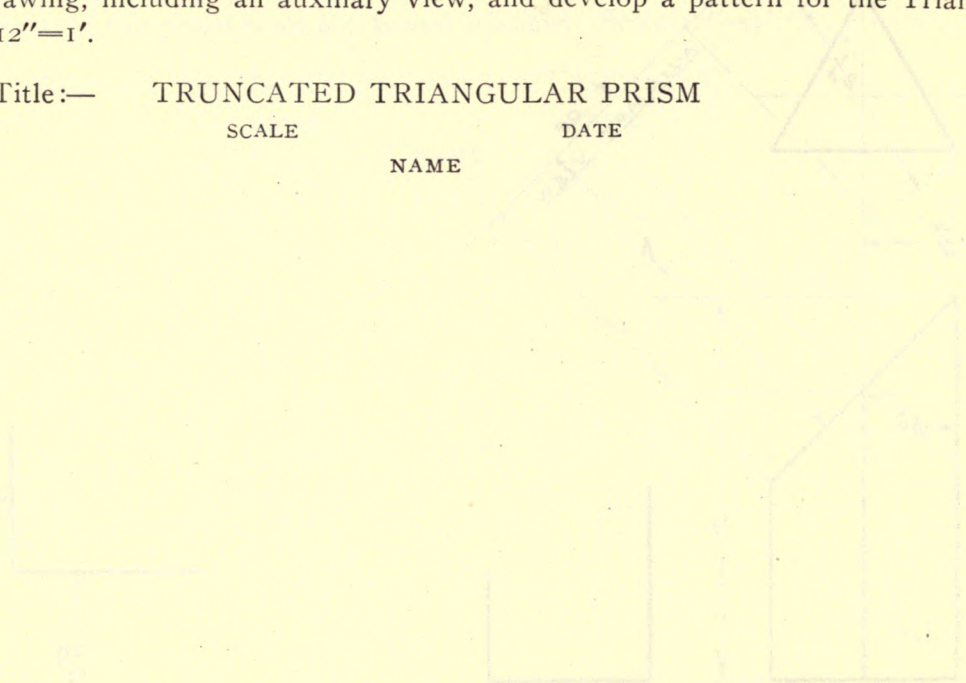

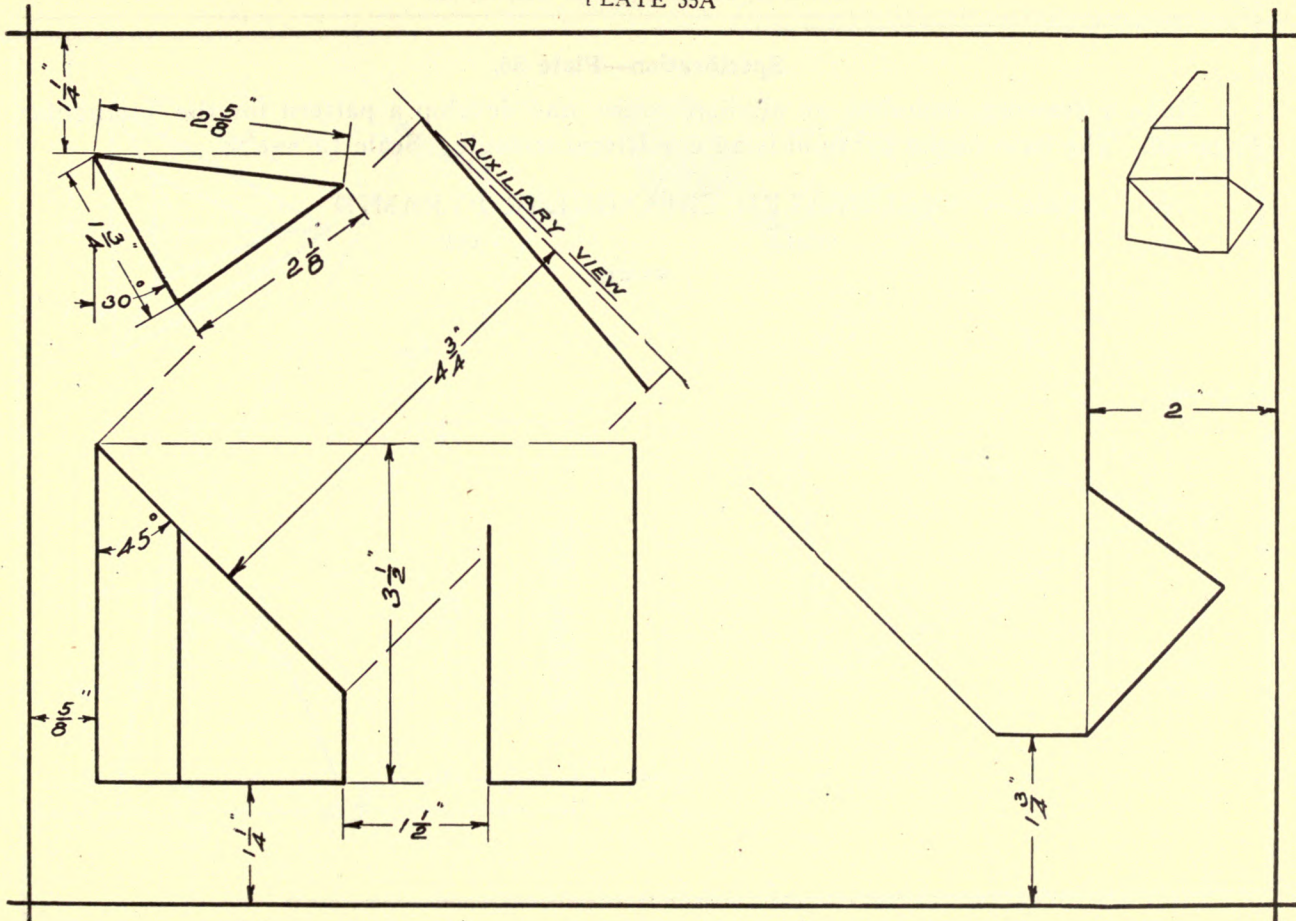

Specification—Plate 36.

Make a drawing, including an auxiliary view, and develop a pattern for the Triangular Pyramid. The base of the pyramid is an equilateral triangle. Scale 12"=1'.

Title:— TRUNCATED TRIANGULAR PYRAMID

SCALE

NAME

DATE

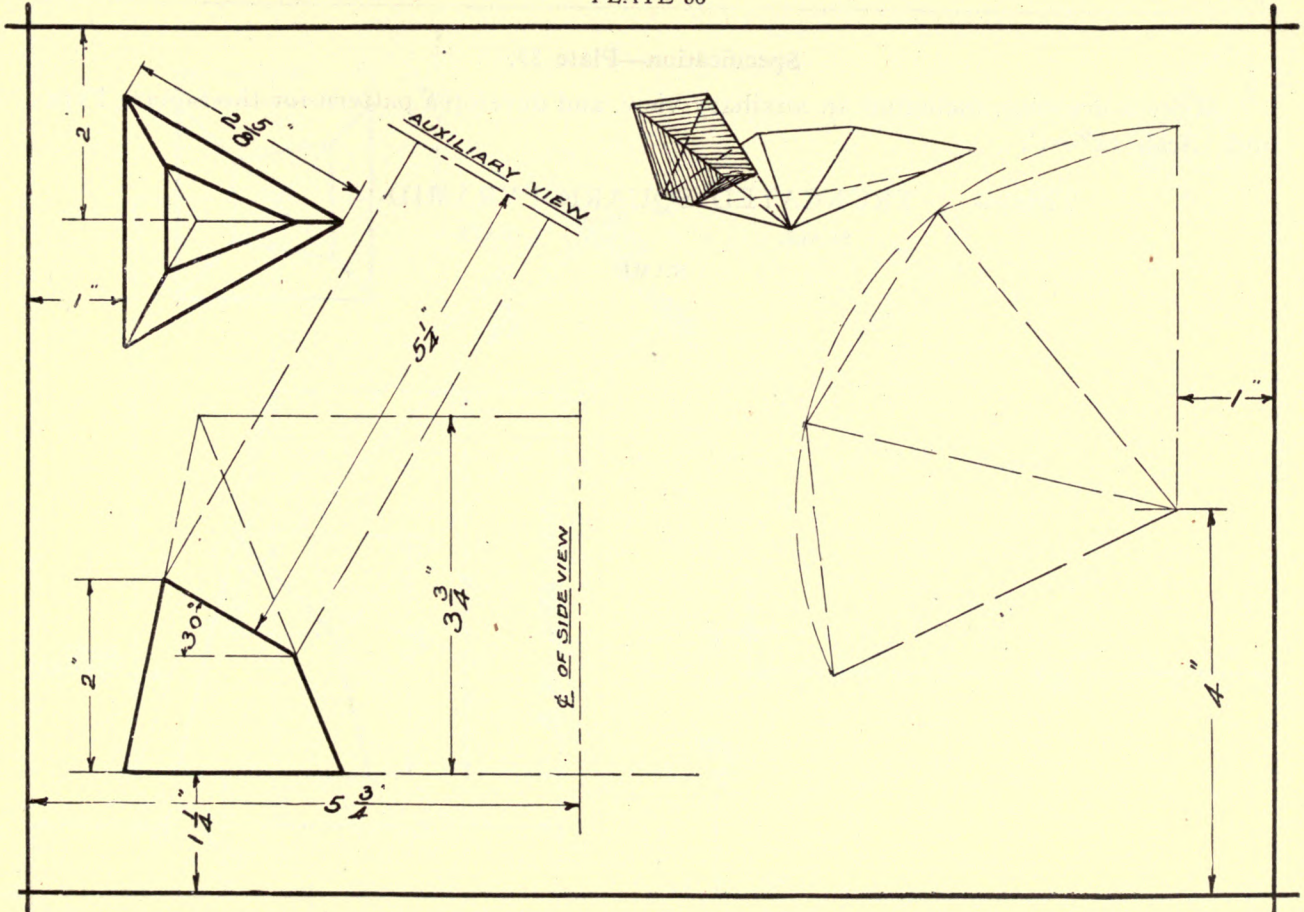

Specification—Plate 37.

Make a drawing, including an auxiliary view, and develop a pattern for the Square Pyramid. Scale 12"=1'.

Title:— TRUNCATED SQUARE PYRAMID

SCALE

DATE

NAME

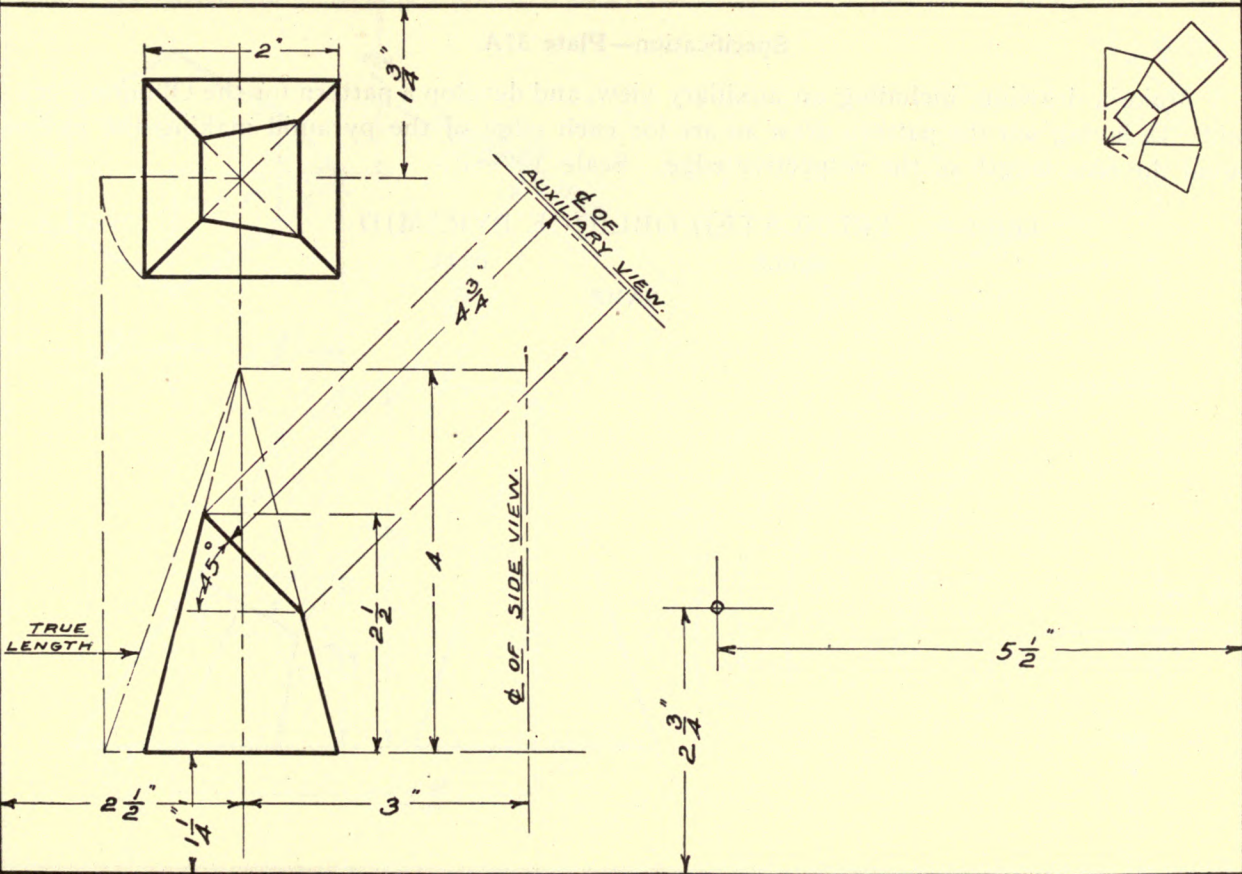

Specification—Plate 37A.

Make a drawing, including an auxiliary view, and develop a pattern for the Oblique Pyramid. In laying out the pattern draw an arc for each edge of the pyramid making the radius equal the true length of the respective edge. Scale 12"=1'.

Title:— TRUNCATED OBLIQUE PYRAMID

SCALE

DATE

NAME

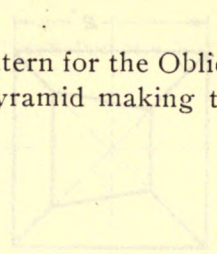

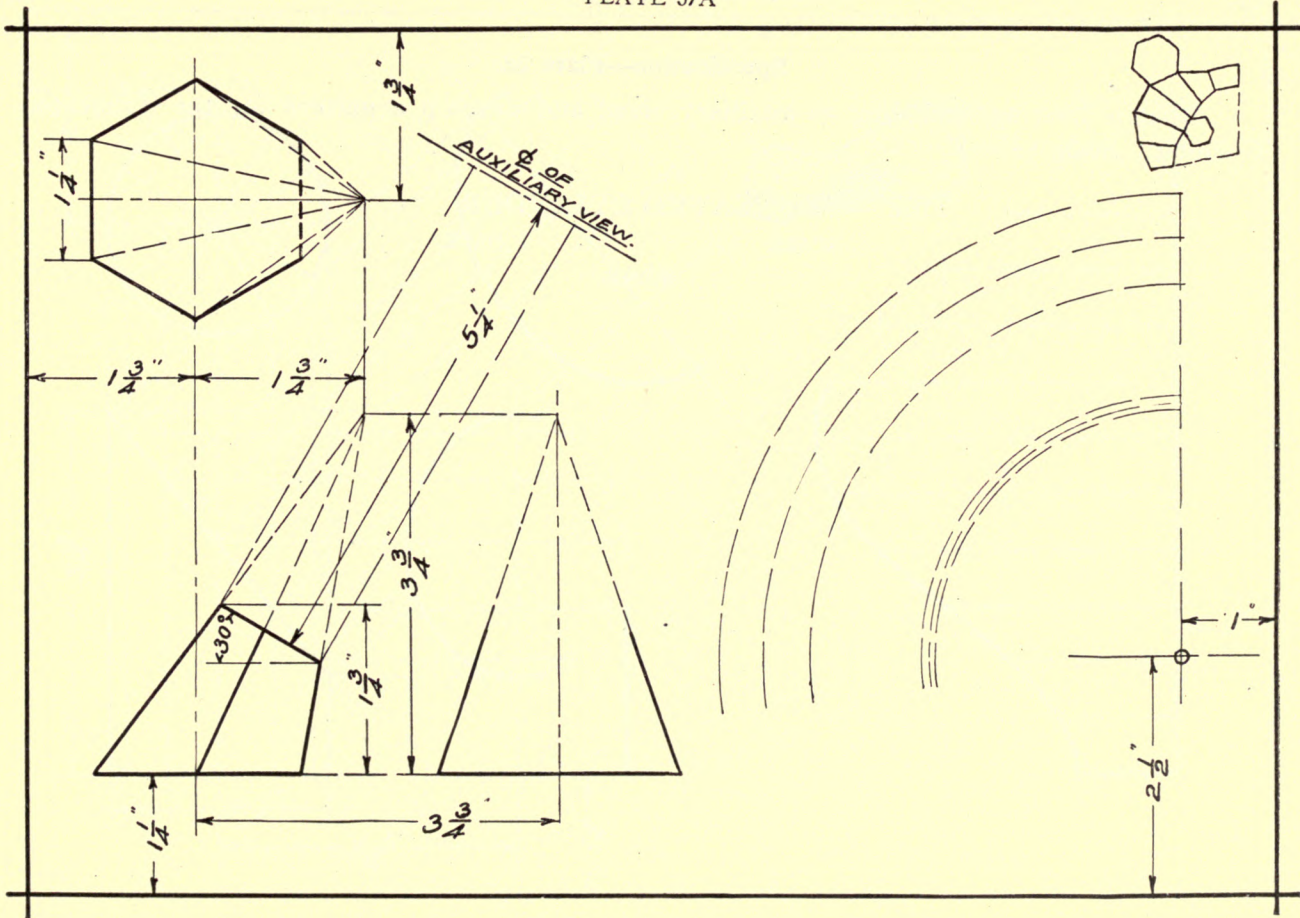

Specification—Plate 38.

Make a drawing, including an auxiliary view, and develop a pattern for the Truncated Cylinder. Scale $12''=1'$.

Title:—TRUNCATED CYLINDER

SCALE

DATE

NAME

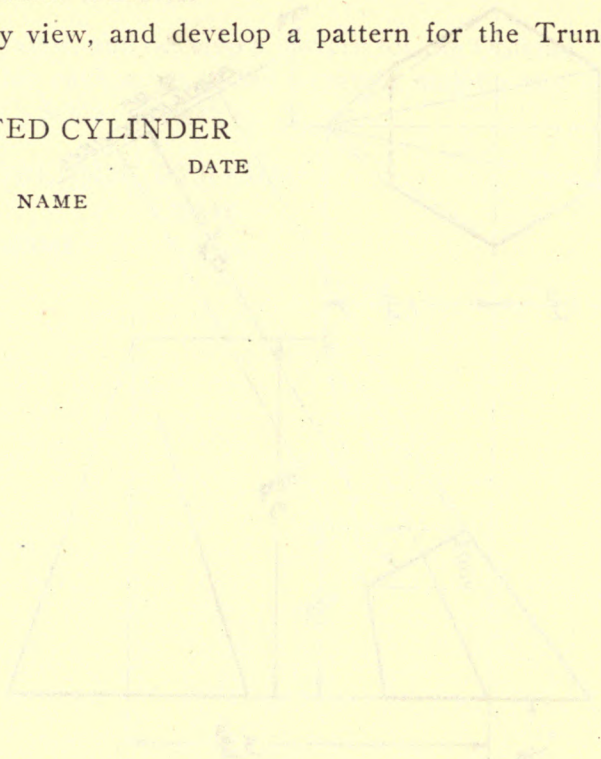

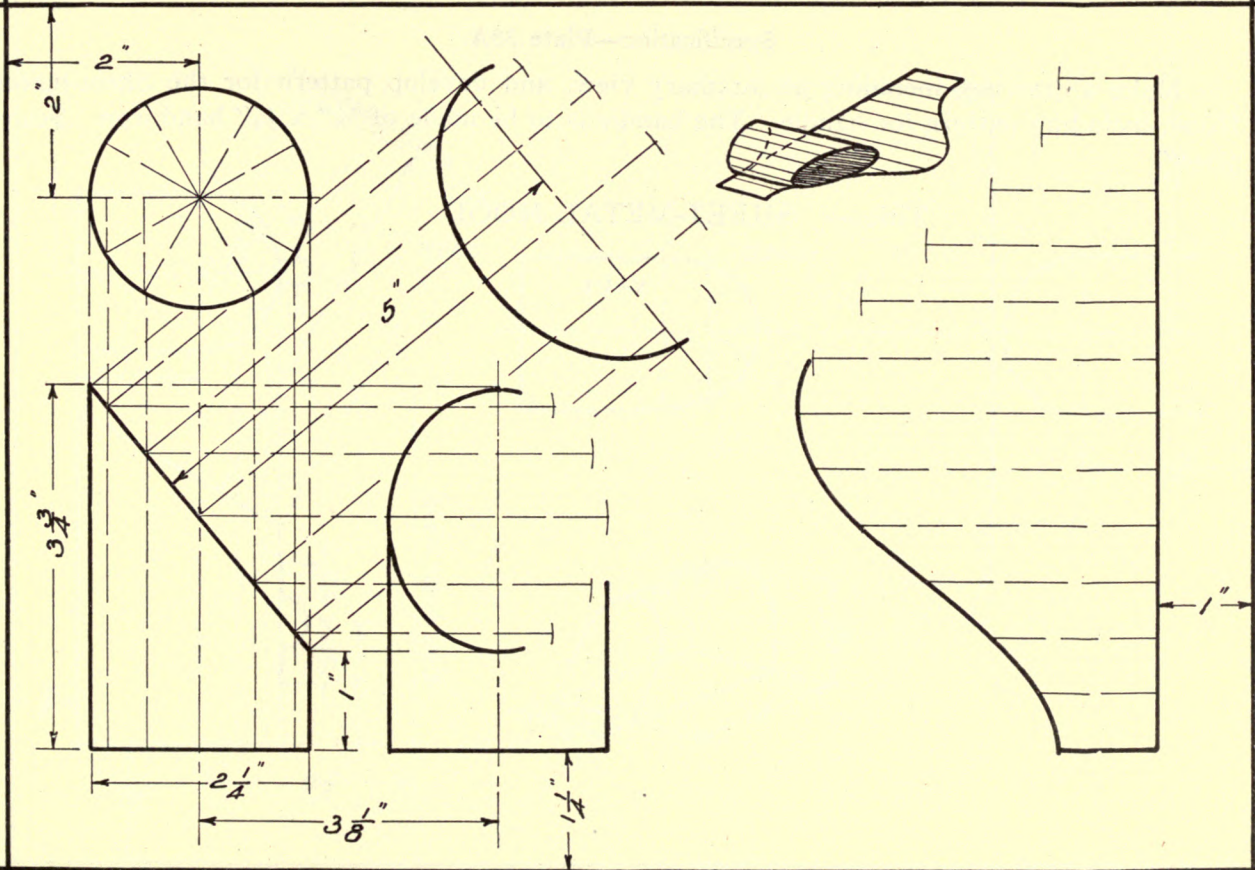

Specification—Plate 38A.

Make a drawing, including an auxiliary view, and develop pattern for the Sheet-metal Hood, including pattern for handle. The handle is to be made of $\frac{1}{8}$ " x $\frac{3}{4}$ " band iron. Scale $3''=1'$.

Title:— SHEET-METAL HOOD

SCALE

DATE

NAME

PLATE 38A

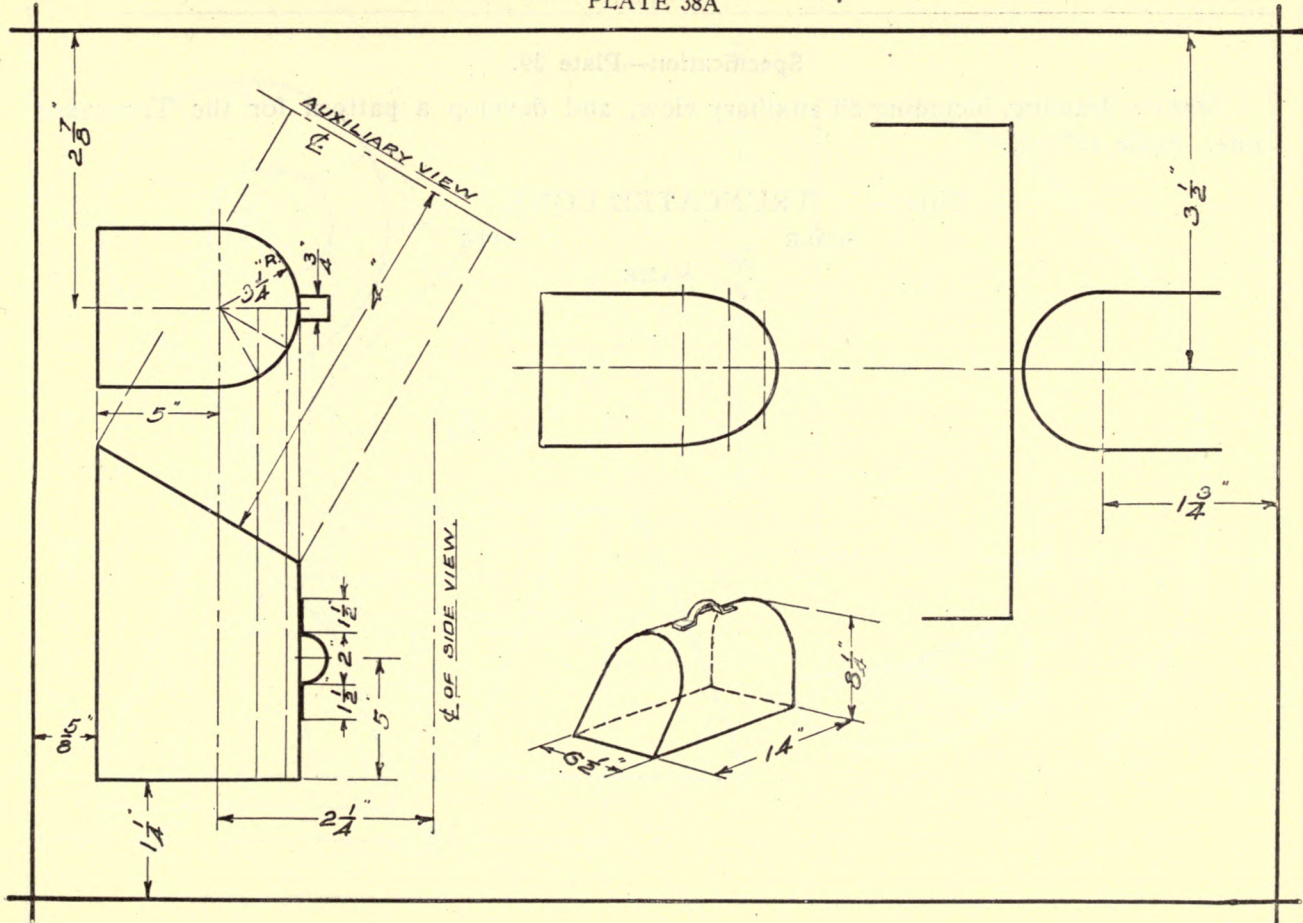

Specification—Plate 39.

Make a drawing, including an auxiliary view, and develop a pattern for the Truncated Cone. Scale $12''=1'$.

Title:— TRUNCATED CONE

SCALE

DATE

NAME



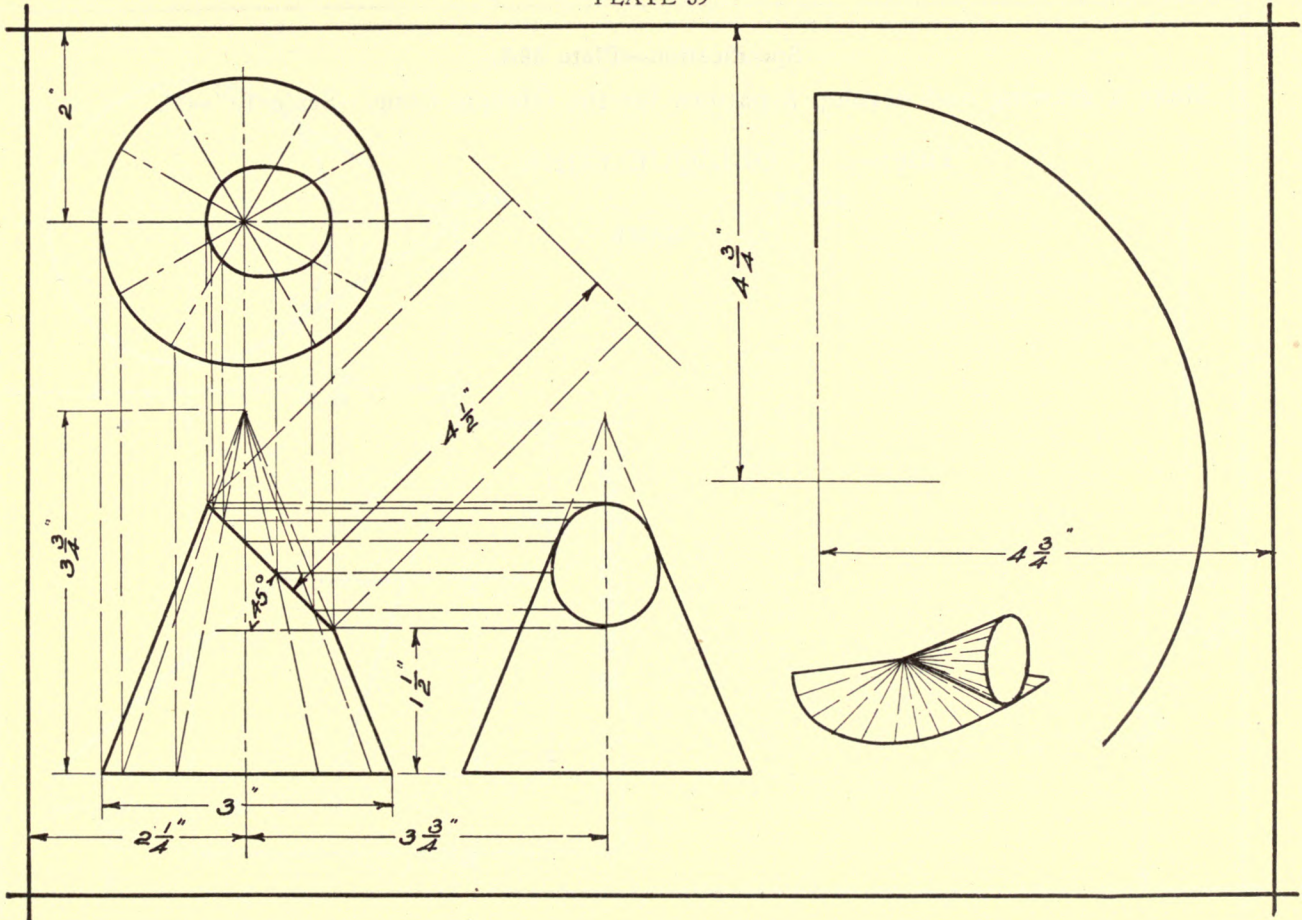

Specification—Plate 39A.

Make a drawing and develop a pattern for the Oblique Cone. Scale 12"=1'.

Title:— OBLIQUE CONE

SCALE

DATE

NAME

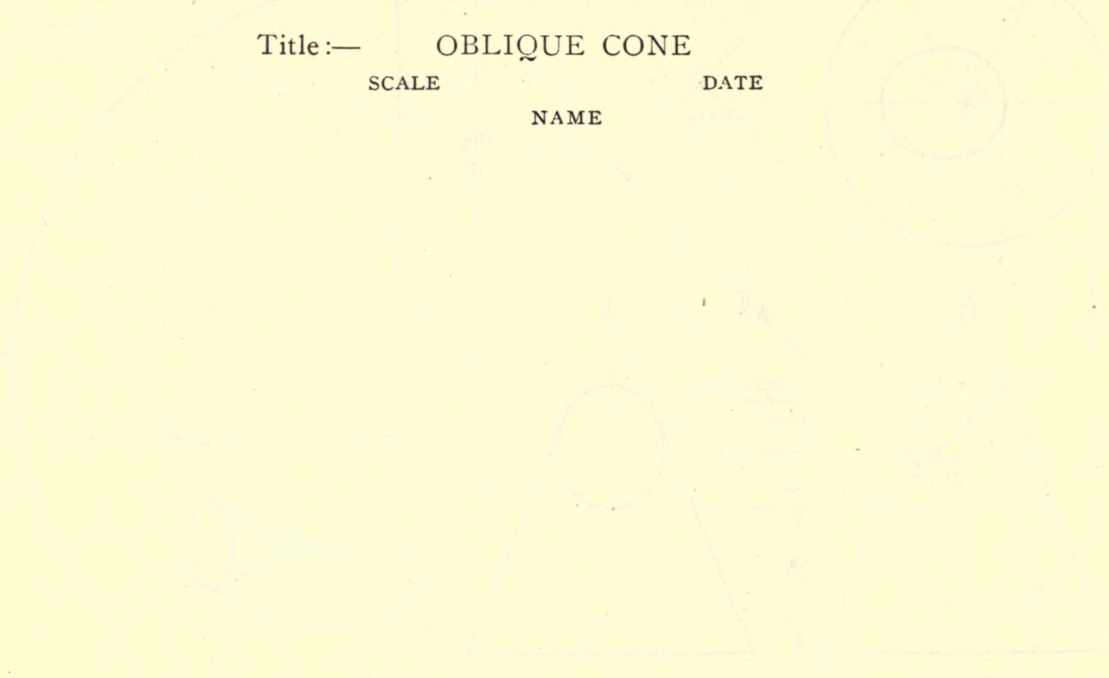

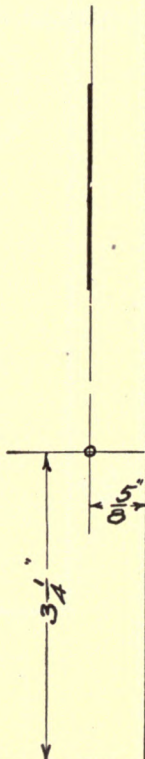
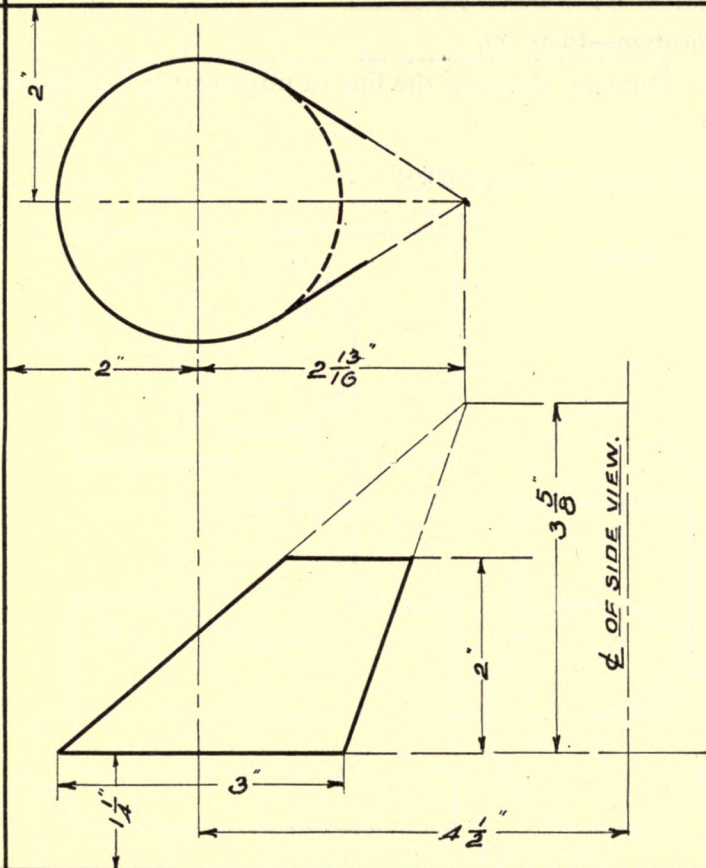

Specification—Plate 40.

Make a drawing of the Intersecting Cylinders, showing the line of intersection. Develop a pattern for each cylinder. Scale 12"=1'.

Title:— INTERSECTING CYLINDERS

SCALE

DATE

NAME

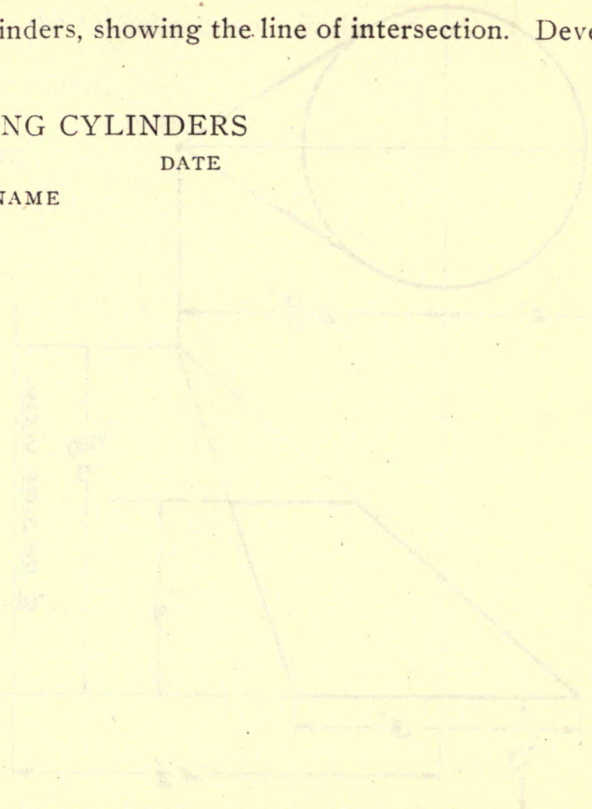

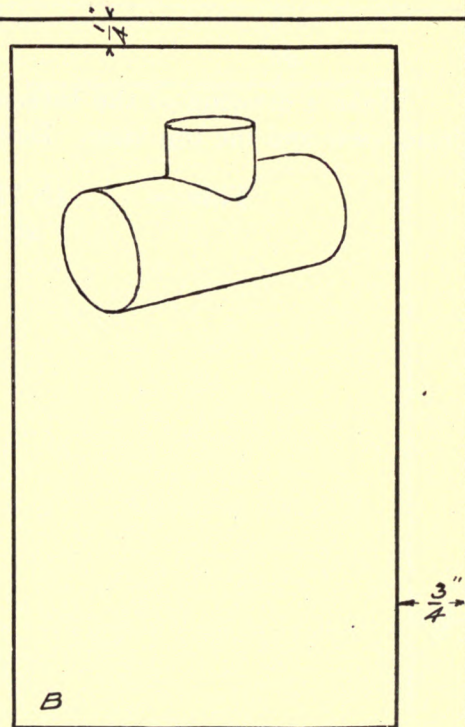
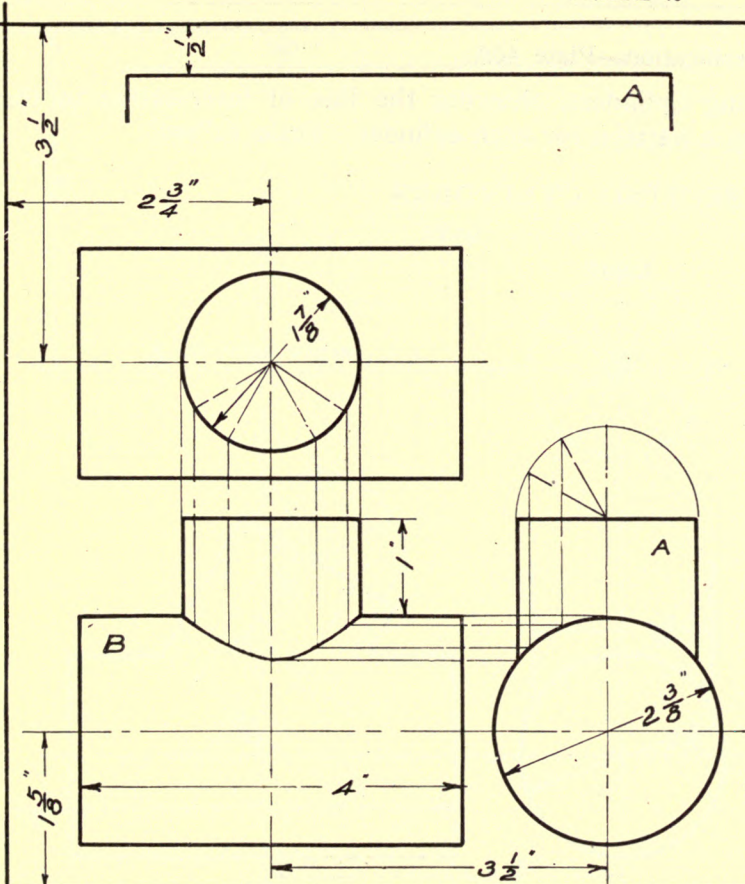

Specification—Plate 40A.

Make a drawing of the Intersecting Cylinders, showing the line of intersection in the front view and the top view. Develop a pattern for each cylinder. Scale 12"=1'.

Title:—

INTERSECTING CYLINDERS

SCALE

DATE

NAME

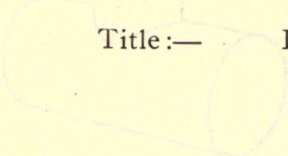
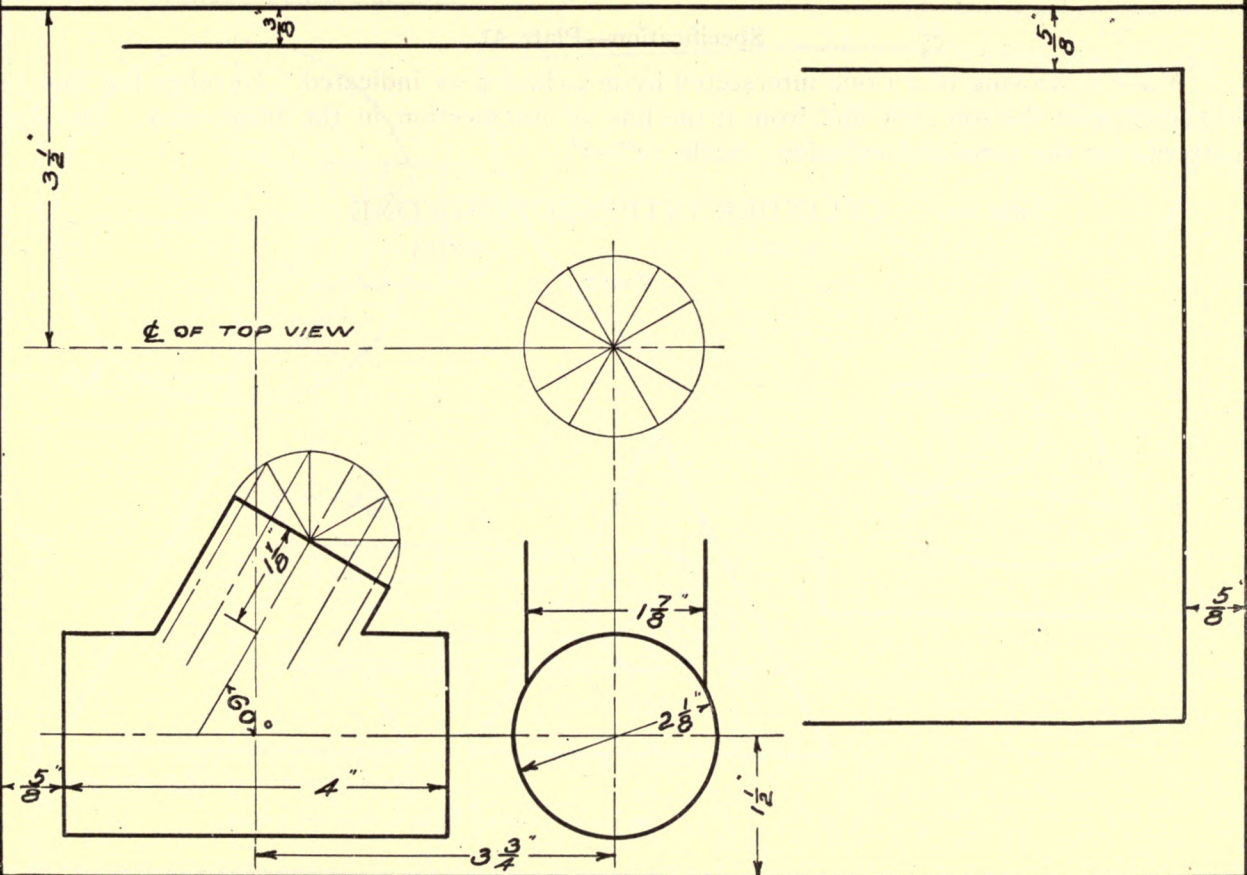

PLATE 40A



Specification—Plate 41.

Make a drawing of a Cone intersected by a Cylinder as indicated. Develop the line of intersection in the top view and from it the line of intersection in the front view. Develop patterns for the cone and cylinder. Scale 12"=1'.

Title:— CYLINDER INTERSECTING CONE

SCALE

DATE

NAME



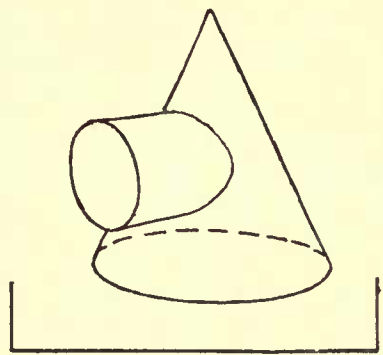
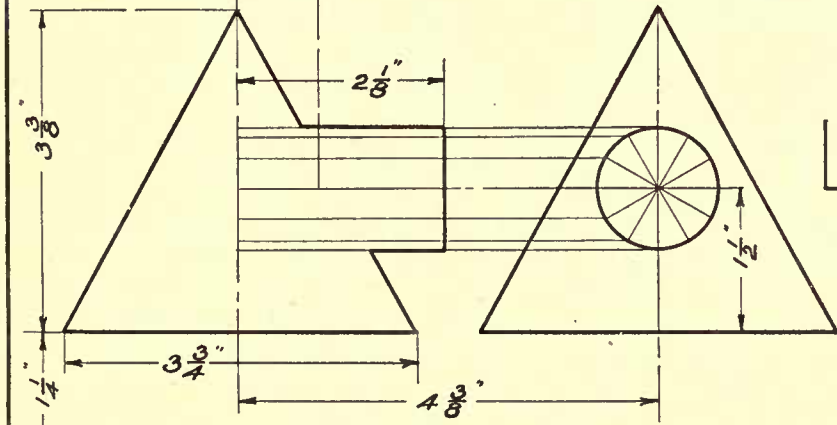
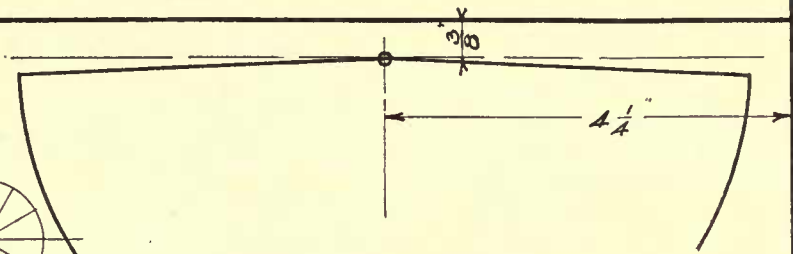
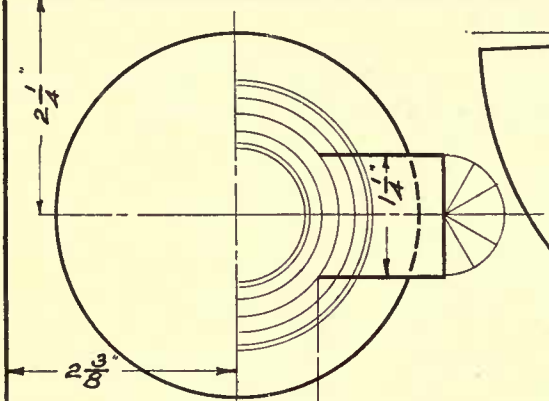

Specification—Plate 41A.

Make a drawing of a Cone intersected by a Cylinder as indicated. Develop the line of intersection in the top view and from it the line of intersection in the front view. Develop patterns for the cone and cylinder. Scale 12"=1'.

Title:— CYLINDER INTERSECTING CONE

SCALE

DATE

NAME

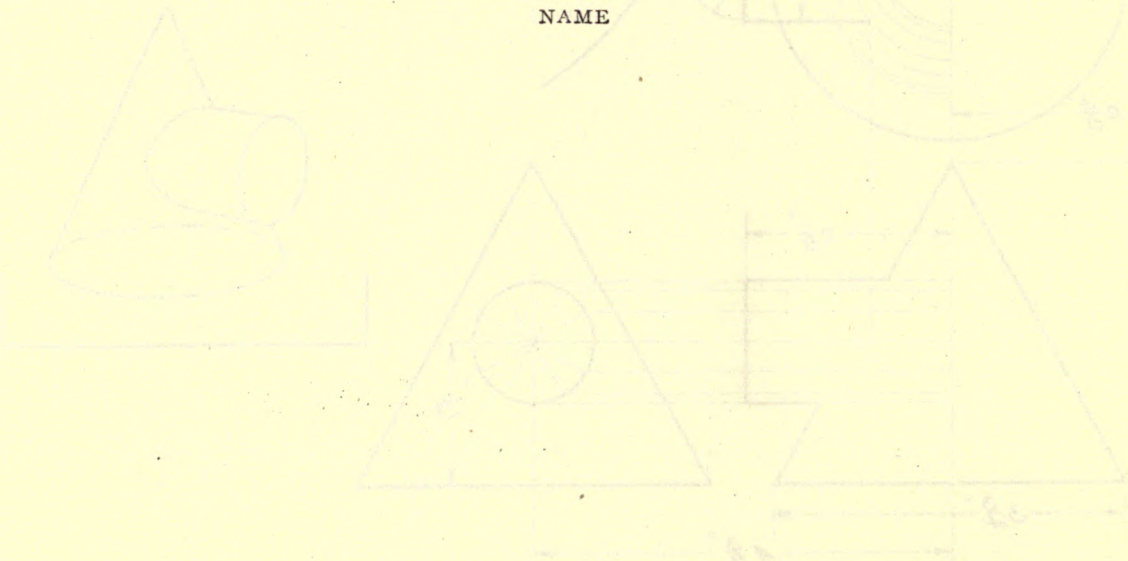
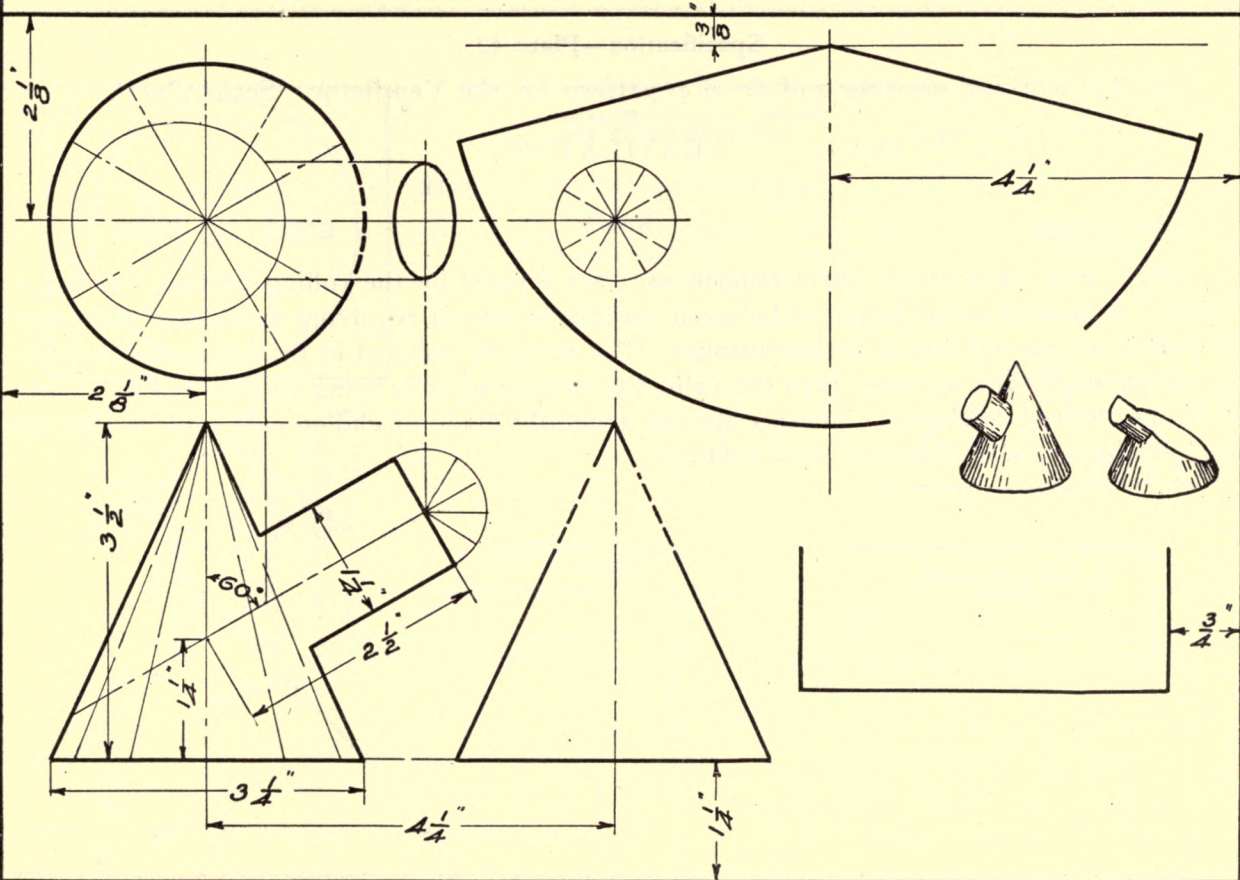

PLATE 41A



Specification—Plate 42.

Make a working drawing and develop pattern for the Ventilator. Scale 3"=1'.

Title:— VENTILATOR

SCALE

DATE

NAME

Sheet iron, sheet steel, sheet copper, etc., are formed by the rolling process. A bar, or "billet," of heated metal is passed between successive sets of revolving cylindrical rolls much as clothes are passed thru a clothes wringer. The metal is reduced in thickness and increased in surface each time it passes thru the rolls, the last set of rolls being so adjusted as to bring it to the desired thickness. These rolls are generally made of chilled cast iron or steel and are very heavy. Metal is also "cold rolled."

PLATE 42

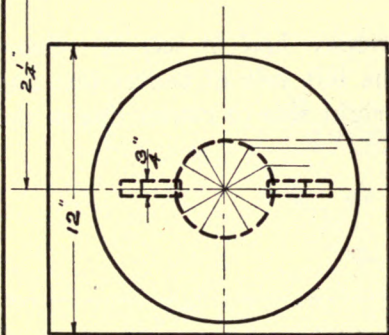

DEVELOP PART A SHOW
LINE OF INTERSECTION

3"

DEVELOP PART
D HERE

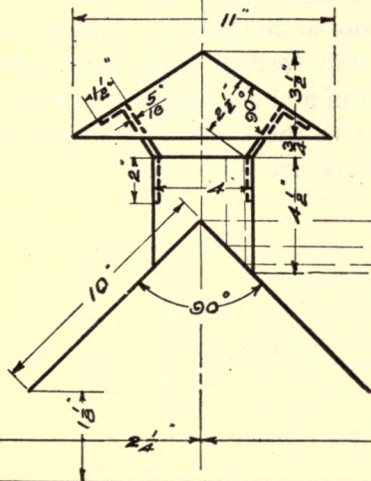

DEVELOP PART C
HERE

3"

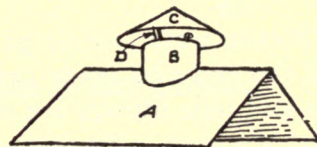

DEVELOP PART B
HERE.

1"

Specification—Plate 42A.

Make a working drawing of the Pipe Tee, showing the front-view half in section. Show the line of intersection formed by the outside of the pipes on the left side of center line and the line of intersection formed by the inside of the pipes on the right side of center line in the front view. Scale 3"=1'.

Title:— REDUCING TEE

SCALE

DATE

NAME

Steam, water, oil or gas frequently passes thru pipes under a high pressure. Connections must therefore be made carefully so that there will be no leakage at the joints. Flanges for pipes and pipe fittings are machined so that they are true and will form a tight joint when bolted together. To further insure a tight joint, a ring cut from a sheet of rubber or other material is placed between the flanges. This ring, which is cut to the shape and size of the flanges, is called a "gasket." Asbestos, copper, and lead gaskets are also used.

PLATE 42A

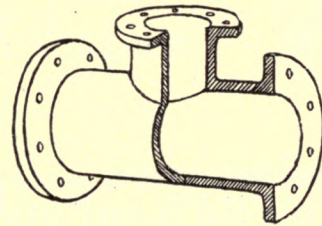
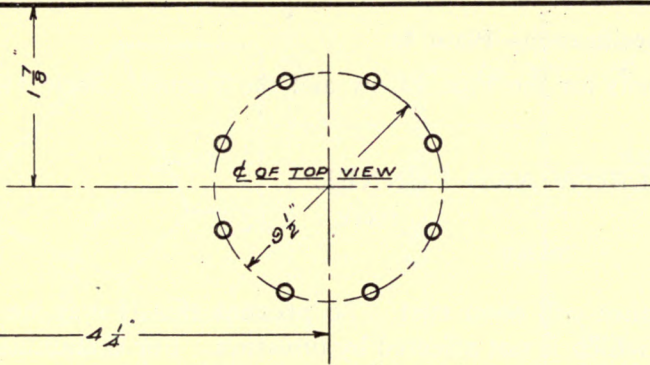

Drill 8 - $\frac{3}{4}''$ holes in both flanges.

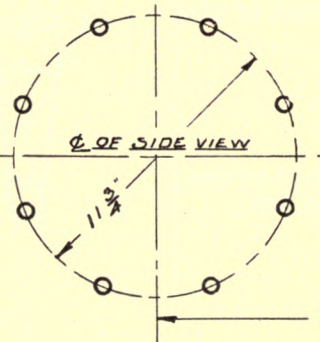
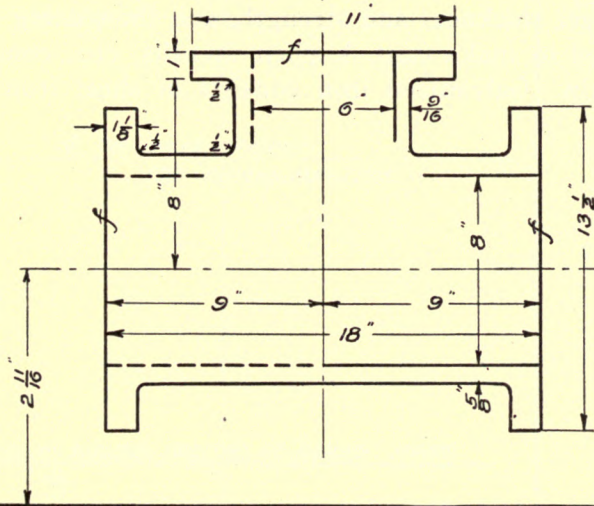

Specification—Plate 43.

Make drawings and develop patterns for the Pipe Elbow and the Funnel. Scale $1\frac{1}{2}''$ and $12''=1'$.

Title:— PIPE ELBOW AND FUNNEL

SCALE

DATE

NAME

Sheet iron when exposed to moisture will soon rust. To prevent this it may be plated with a thin coat of some other metal which is not affected by moisture. For certain uses this is very desirable as the iron gives the sheet thickness and strength, and the plating affords a protection. So-called "tin" which is used to make cans, kitchen utensils, etc., consists of sheet iron plated with a very thin coat of tin. Galvanized iron consists of sheet iron plated with a thin coat of zinc.

PLATE 43

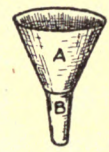
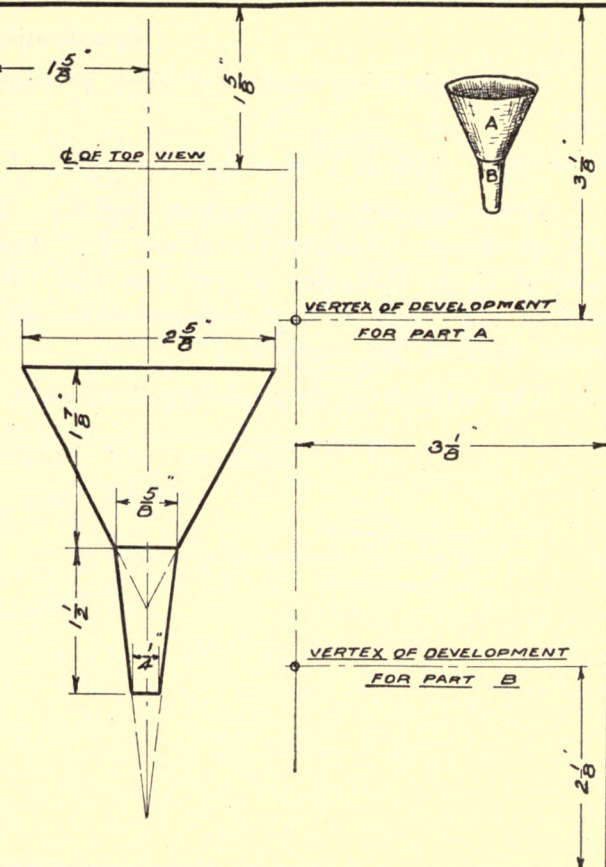
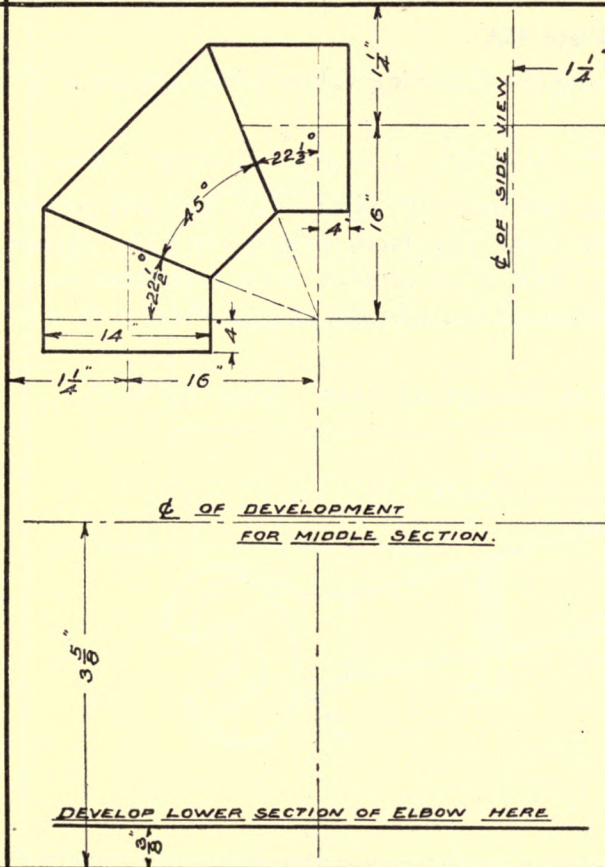

Specification—Plate 43A.

Make a drawing of the 15° Fork Wrench, using the following values which are for a $\frac{3}{4}$ " nut.

$C = 1\frac{3}{16}"$, $D = \frac{1}{8}"$, $H = \frac{1}{16}"$, $I = 1\frac{3}{8}"$, $J = 1"$, $K = \frac{7}{8}"$, $L = \frac{9}{32}"$, $M = \frac{1}{2}"$, $N = 9"$.

Draw line OA 15° to center line ZY. Draw OB and OE 45° to OA, and FG 75° to ZY as shown. Tangent to circle of C diameter draw jaw faces parallel to OA. Space half of D on each side of 75° line FG. With x and x' as centers, draw arcs from outer end of jaw faces to lines OB and OE. With O as center, join the ends of these arcs, also inner ends of jaw faces.

The wrench is dropped-forged of steel and is finished all over. Scale $12" = 1'$.

Title:— 15° FORK WRENCH

SCALE

DATE

NAME

PLATE 43A

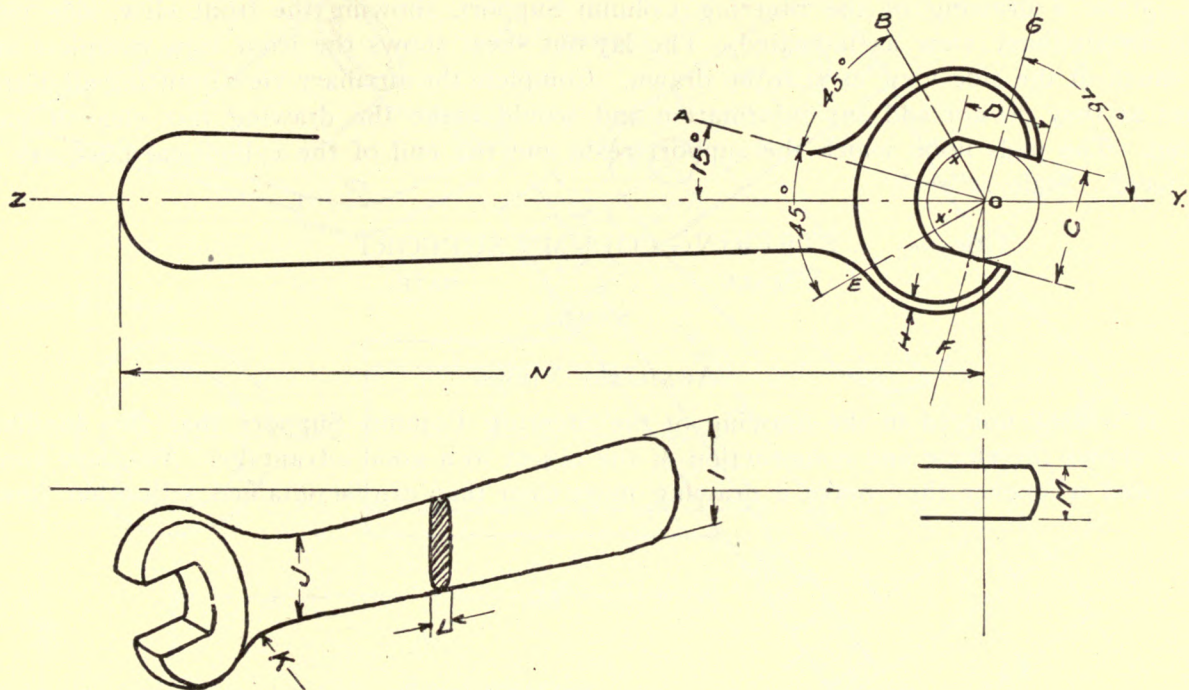

Specification—Plate 44.

Make a drawing of the Steering Column Support, showing the front view, side view and an auxiliary view as indicated. The lay-out sheet shows the front view complete and as much of the side view as is to be drawn. Complete the auxiliary view omitting all dotted lines as they do not add any information and would make the drawing less clear if indicated. The pads upon which the support rests and the end of the cylindrical boss, are to be faced. Scale 12"=1'.

Title:— STEERING COLUMN SUPPORT

SCALE

DATE

NAME

AUXILIARY VIEWS.

It will be noticed in the drawing of the Steering Column Support that the auxiliary view shows the shape and construction of the object to a good advantage. Auxiliary views are used whenever they make a drawing more clear than can be obtained with other views.

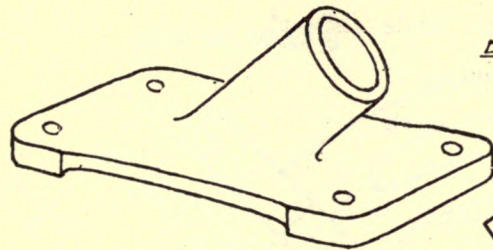

Drill holes $\frac{1}{8}$ "

8" Rad.

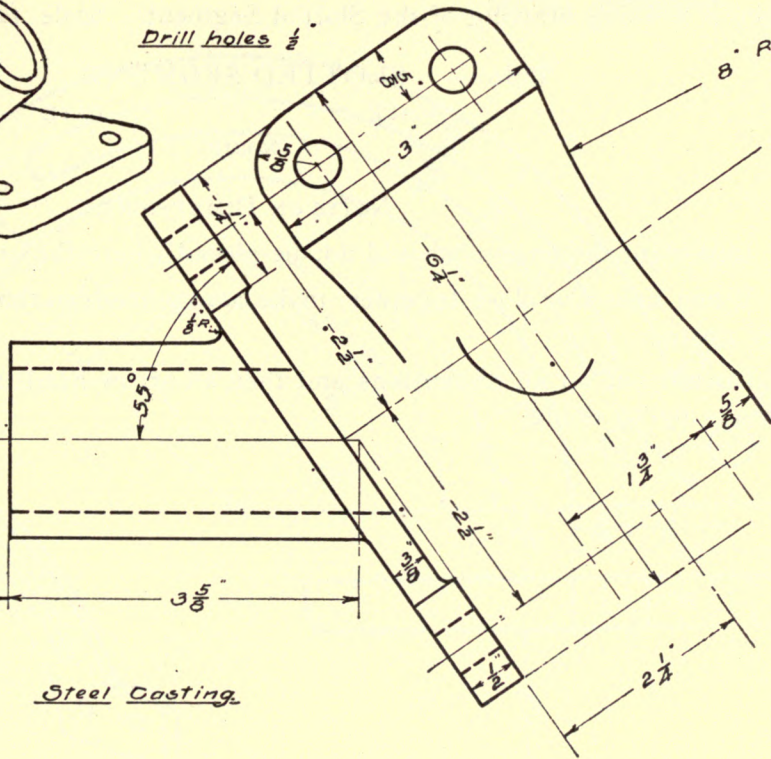
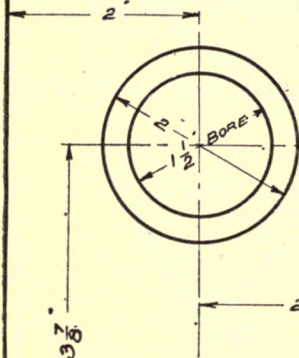

Steel Casting

Specification—Plate 44A.

Make a working drawing of the Slotted Segment. Scale 12"=1'.

Title:— SLOTTED SEGMENT

SCALE

DATE

NAME

NOTES ON DIMENSIONS.

1. Important dimensions should not be placed where they may be overlooked.
2. When lines are close together, make arrow-heads so that the workmen can tell which line they go to.
3. Do not put on all dimensions and then all arrow-heads as you may miss some of the arrow-heads by so doing.

CAST BRASS

Drill all holes $\frac{7}{16}$ "

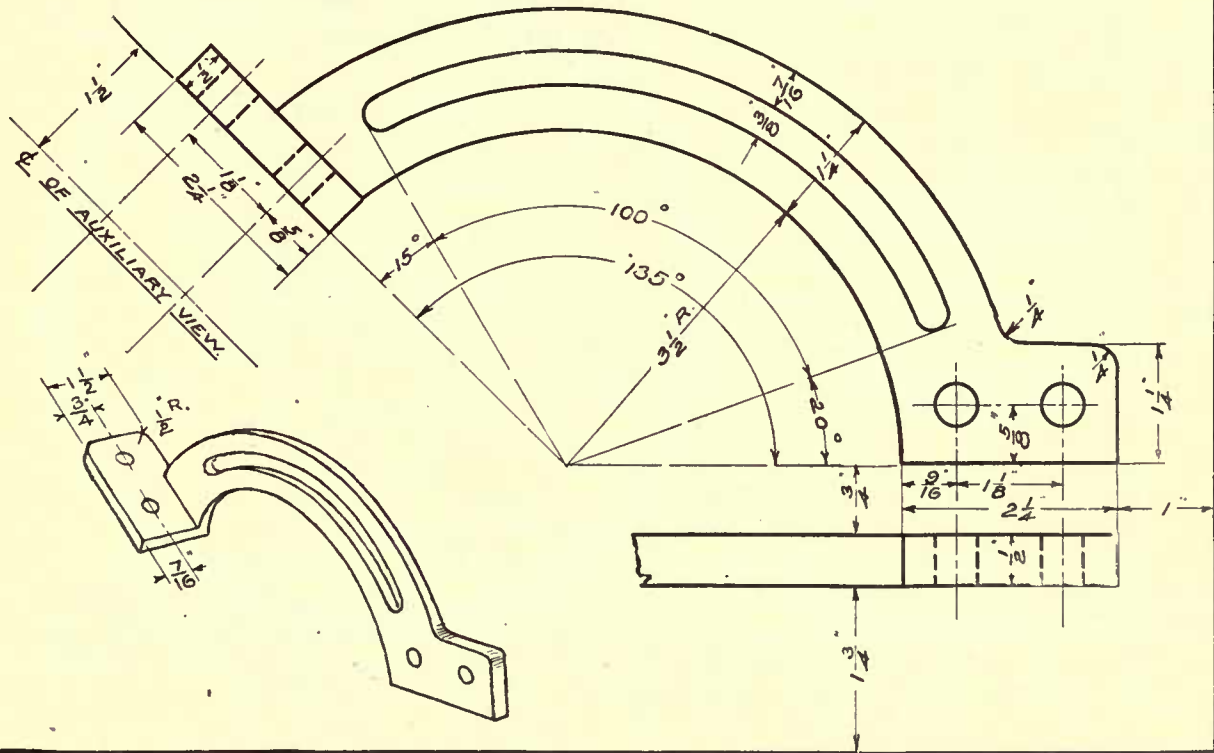

Specification—Plate 45.

Make a drawing of a Cast Iron Pulley 7" in diameter for 3" belt. Scale 12"=1". Use the following values which are taken from formulas and tables by J. W. See, American Machinist Hand Book, and are based on the diameter of pulley, width of belt and diameter of shaft.

Dia., 7".	F = $\frac{1}{4}$ " thickness of rim at center.
W = width, $3\frac{1}{2}$ ".	G = $\frac{1}{8}$ " thickness of rim at edge.
S = $1\frac{1}{4}$ " diameter of shaft.	O = $\frac{1}{2}$ of C.
B = $\frac{1}{8}$ " width of arm at center.	Y = E.
C = $\frac{9}{16}$ " width of arm at circumference.	I = 3" distance across web.
D = $\frac{3}{8}$ " thickness of arm at center.	J = $2\frac{1}{4}$ " diameter of hub.
E = $\frac{1}{4}$ " thickness of arm at circumference.	L = $2\frac{1}{2}$ " length of hub.

Title:— CAST IRON PULLEY

SCALE

DATE

NAME

CONVENTIONAL SECTIONS.

It will be noticed in the drawing of the pulley that the arms are not sectioned in the side view as would be the case in a true projection from the front view. This is done to show clearly the shape of the hub and the rim and is customary in drawings of objects involving spokes, arms, or ribs. The "revolved section" of the arm is also a conventional method of showing the shape of such members or parts. See page 197.

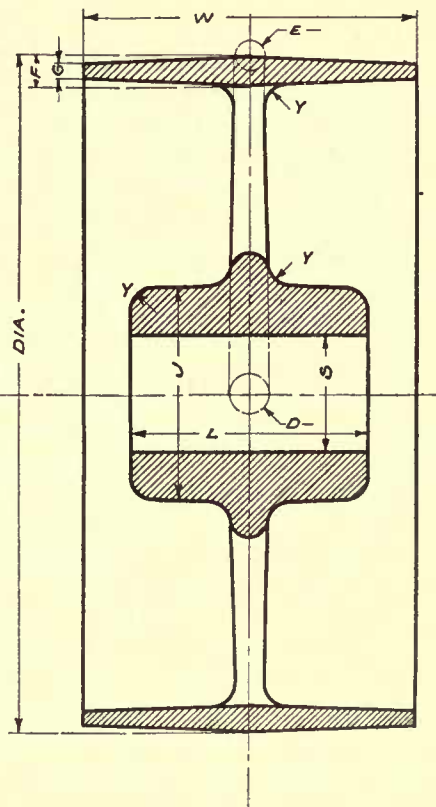
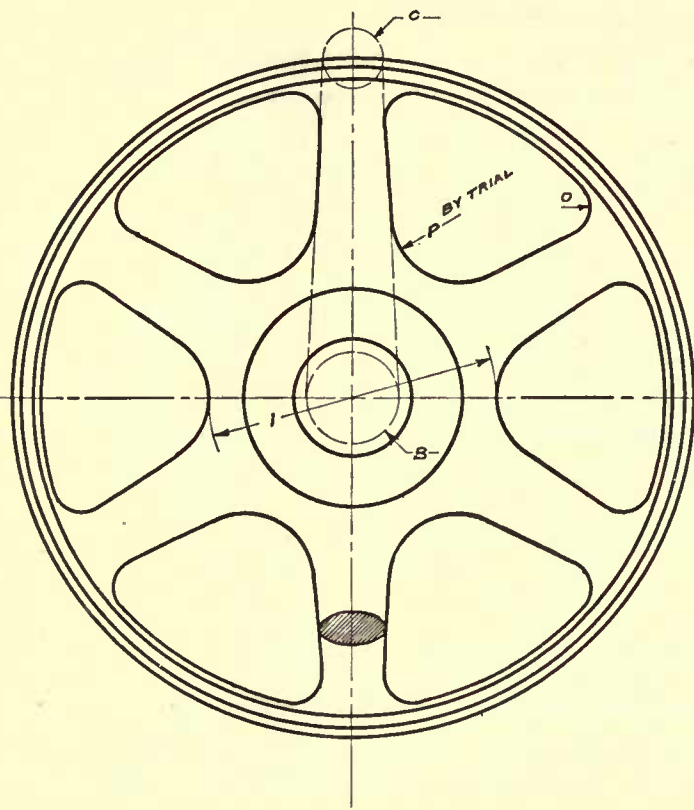

Specification—Plate 45A.

Make a full-size drawing of a 7" Hand Wheel, using the following values which are derived from formulas and tables based on the diameter of the wheel.

A = 7" diameter of wheel.

B = $\frac{15}{16}$ " diameter of rim.

C = $\frac{5}{8}$ " offset.

D = $2\frac{1}{8}$ " diameter across web.

E = $\frac{3}{8}$ " thickness of arm at hub.

F = $\frac{1}{2}$ " thickness of arm at rim.

G = $\frac{5}{8}$ ".

H = $1\frac{1}{16}$ ".

J = $1\frac{1}{16}$ ".

K = $1\frac{7}{16}$ ".

L = $\frac{3}{8}$ " width of arm at rim.

M = $\frac{1}{8}$ " width of arm at hub.

O = 1.25 x B length of hub.

Diameter of hub = D minus E.

When reverse curves are to be joined as at x, a short straight line should be used to connect them to prevent an apparent kink in the finished curve. This rule may be ignored when drawing small curves of the same radius. Scale 12"=1'.

Title:— 7" HAND WHEEL

SCALE

DATE

NAME

CONVENTIONAL SECTIONS.

In a drawing of a pulley or wheel which has an uneven number of spokes or arms, the sectional view should be represented as if there were two arms opposite each other, as in the hand wheel. The other view should show one of the arms in a vertical position above the horizontal center line.

PLATE 45A

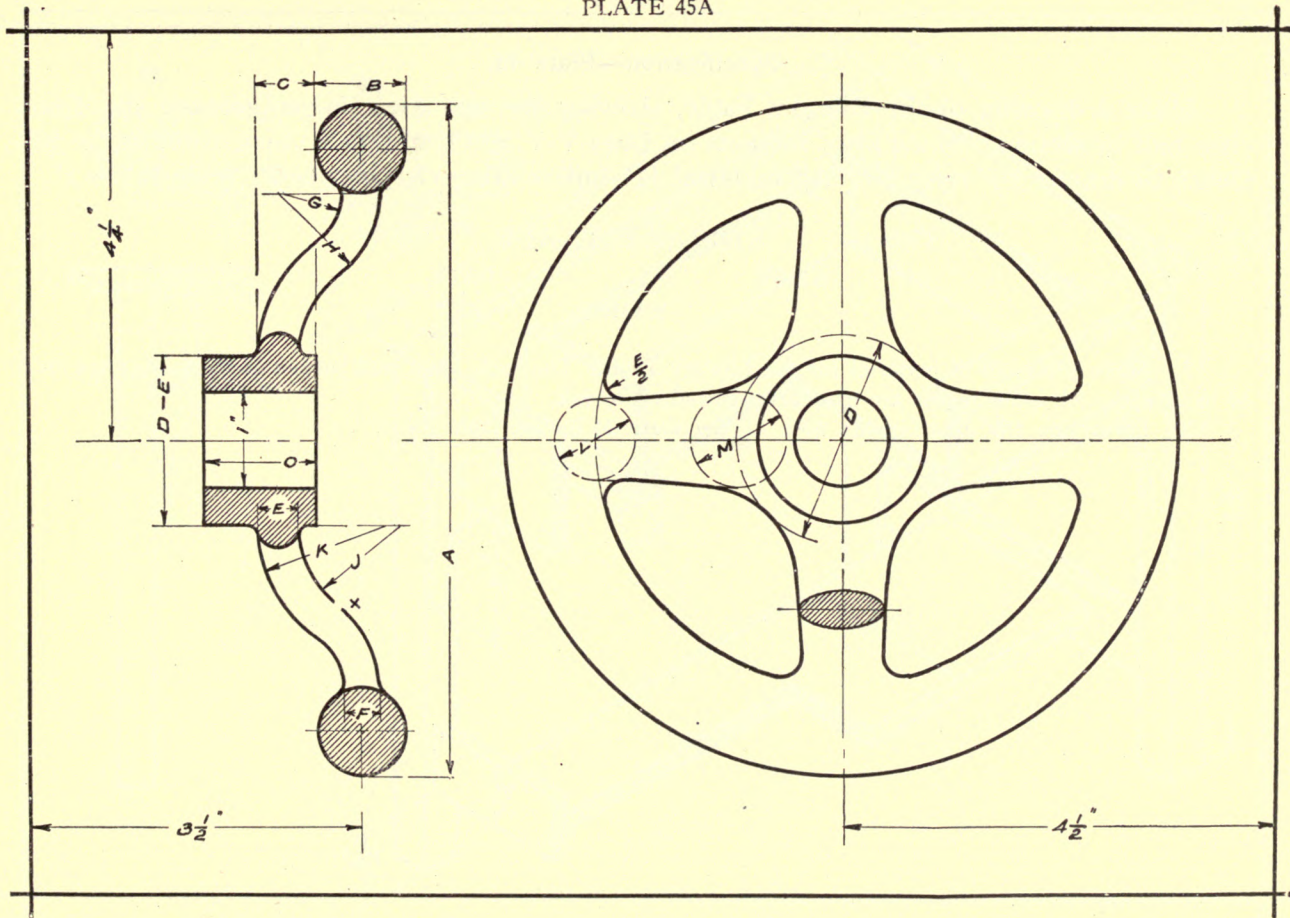

Specification—Plate 46.

Make a drawing of the Library Table, showing the end view in section and the front-view half in section. Show also, sections on lines V-V, O-O, and X-X. Size of top 24" x 36". Depth of drawer 19" over all. All material $\frac{3}{4}$ " unless otherwise specified. Scale $\frac{3}{16}$ " = 1".

Title:— LIBRARY TABLE

SCALE

DATE

NAME

1. Make out a bill of material for the Library Table. The back, sides, and bottom of the drawer are made of basswood. All other pieces are of quarter-sawed white oak.
2. Determine the approximate cost of the material for the table.

Specification—Plate 46A

Make a drawing of the Bed to a suitable scale. The foot end of the bed may be drawn directly in front of the head end with a left-side view in section of the foot end and a right-side view in section of the head end. A separate drawing is made of the side rails. The rails are fastened to the ends of the bed by means of cast-iron rail fasteners which work on a wedge-hook principle.

Title:— SINGLE BED
SCALE _____ DATE _____
NAME _____

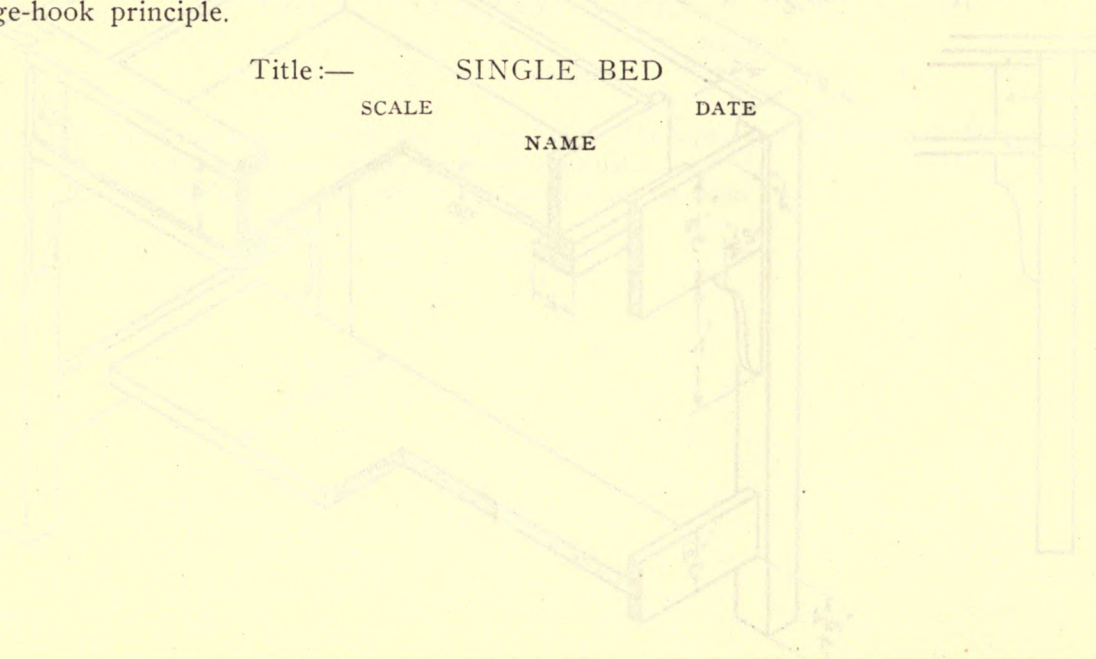

ALL RAILS $1\frac{1}{4}$ " MATERIAL
POSTS 2" X 2" "

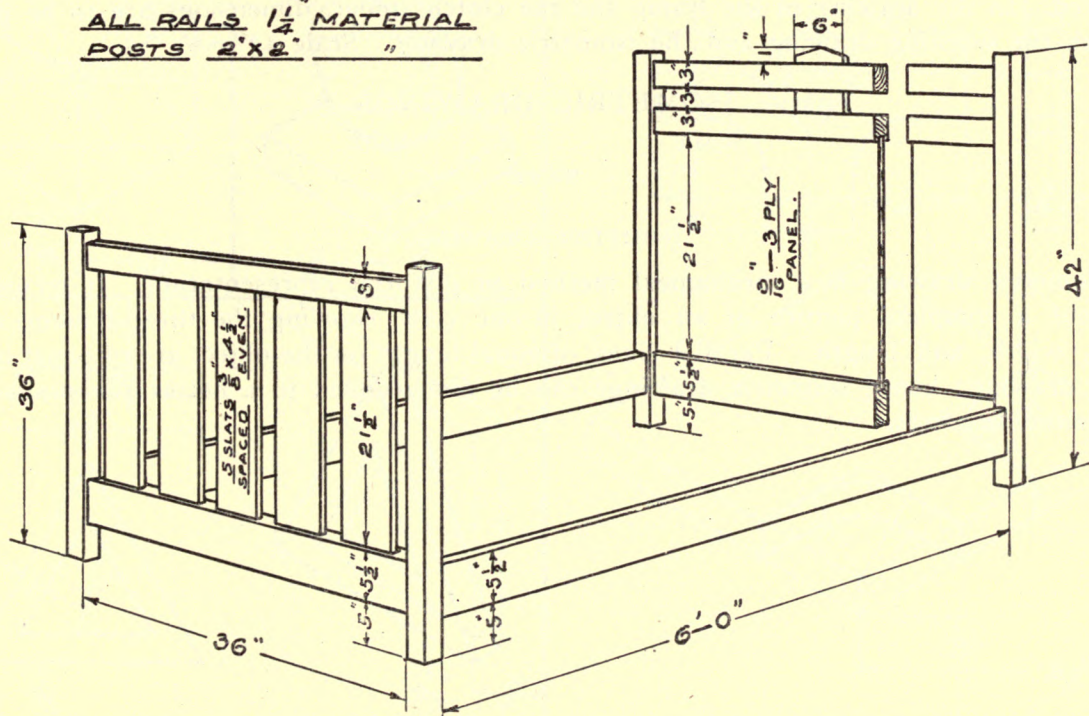

Specification—Plate 47.

Make isometric drawings of a $1\frac{3}{8}$ " cube; a circular block $\frac{5}{16}$ " thick by $1\frac{1}{2}$ " diameter resting on a block $\frac{5}{8}$ " thick by $1\frac{1}{2}$ " square; a triangular frame and a clutch spider as indicated. In the drawing of the frame and the clutch spider, dimensions are to be placed on both the working drawing and the isometric drawing. Scale $12''=1'$.

Title:— ISOMETRIC DRAWINGS

SCALE

DATE

NAME

ISOMETRIC DRAWING.

Isometric drawing is a mechanical method of pictorial representation. It is used to represent a complete picture of an object in one view, showing the three dimensions of height, width, and length. Parallel lines of equal length on the object are of equal length in the drawing; hence isometric drawings can be dimensioned to a better advantage than perspective drawings.

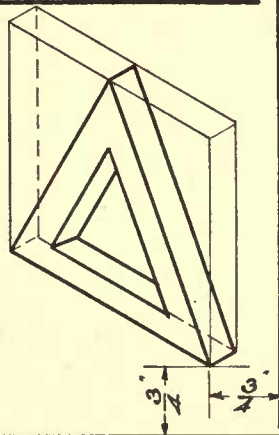
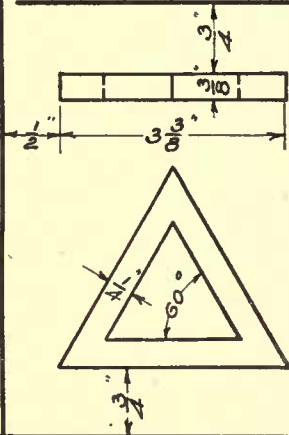
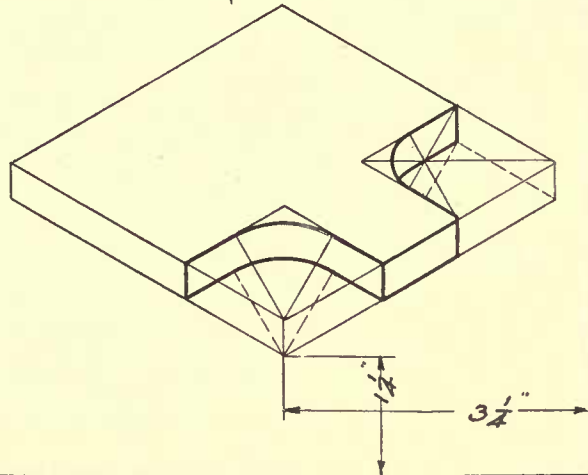
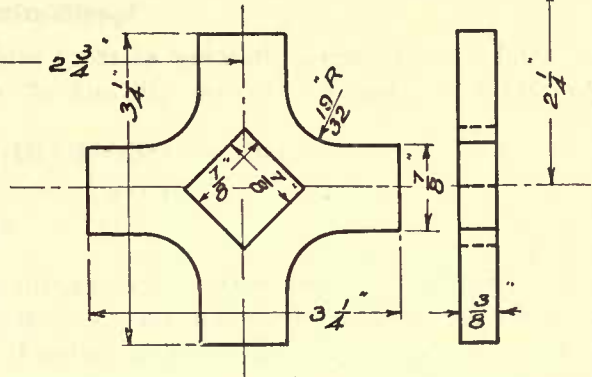
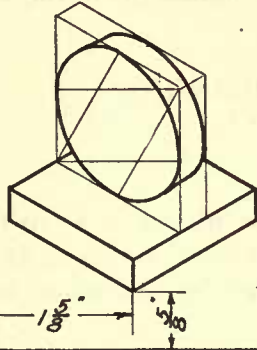
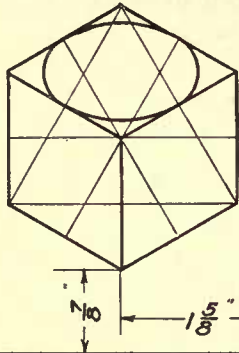

Specification—Plate 47A.

Make an isometric drawing of the Crank as indicated by the working drawing; also of the Brace in Plate 7A. Scale 12" and 9" = 1' .

Title:— ISOMETRIC DRAWINGS

SCALE

DATE

NAME

Dimensions on isometric drawings should be placed so as to read from *left to right* or from the *bottom up*. Dimension lines should always be parallel to an isometric axis. In indicating the diameter of circles it is better to place the dimension outside of, rather than on the isometric circles.

PLATE 47A

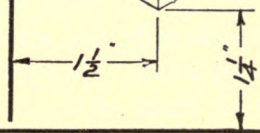
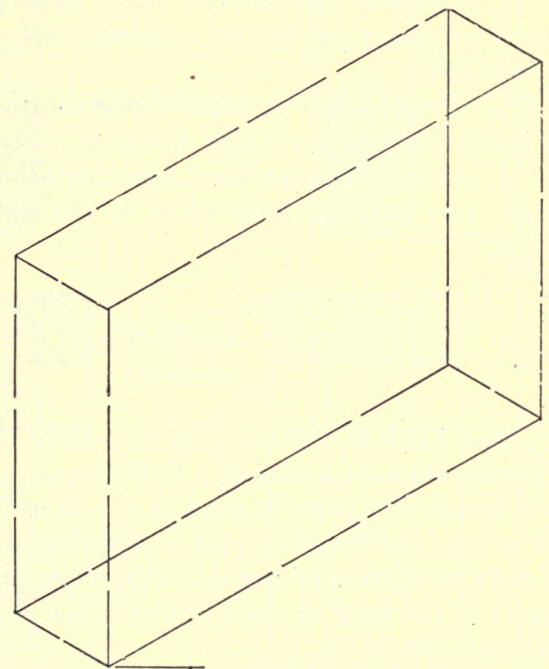
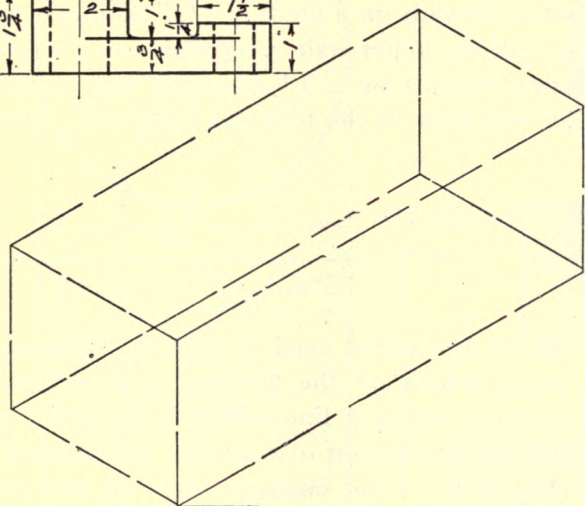
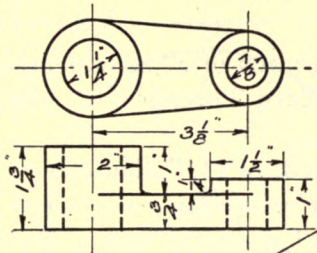

Specification—Plate 48.

1. Draw a helix of two turns having a diameter of $3\frac{1}{4}$ " and a pitch of 2" as indicated.
2. Draw a profile, or sectional view of the United States Standard Thread of 1" pitch as indicated.
3. Draw a conventional representation of screw-threads on a piece of $1\frac{1}{4}$ " diameter rod as indicated. Also a block threaded to fit a $1\frac{1}{4}$ " screw, upper half in section.
4. Draw a conventional representation of screw-threads on a 1" diameter rod as indicated; also a block threaded to fit the rod and an end view of the block as indicated. Scale $12''=1'$.

Title:— U. S. STANDARD THREAD

SCALE

DATE

NAME

The helix is the curve of the screw-thread and is the curve used in making the actual representation of a thread. It is the path of a point traced on the surface of a revolving cylinder as the point moves at a uniform rate of speed along a line which is parallel with the axis of the cylinder, and at some regular prescribed proportion of travel in this direction to each revolution of the cylinder. The pitch of the helix is the distance between any two points in the path of the cylinder measured parallel with the axis of the cylinder. See pages 199 and 200.

In the drawing of screw-threads the actual form of the thread is seldom represented, as it involves too much time and work. Conventional forms have been adopted, two of the most common being shown in Plate 48.

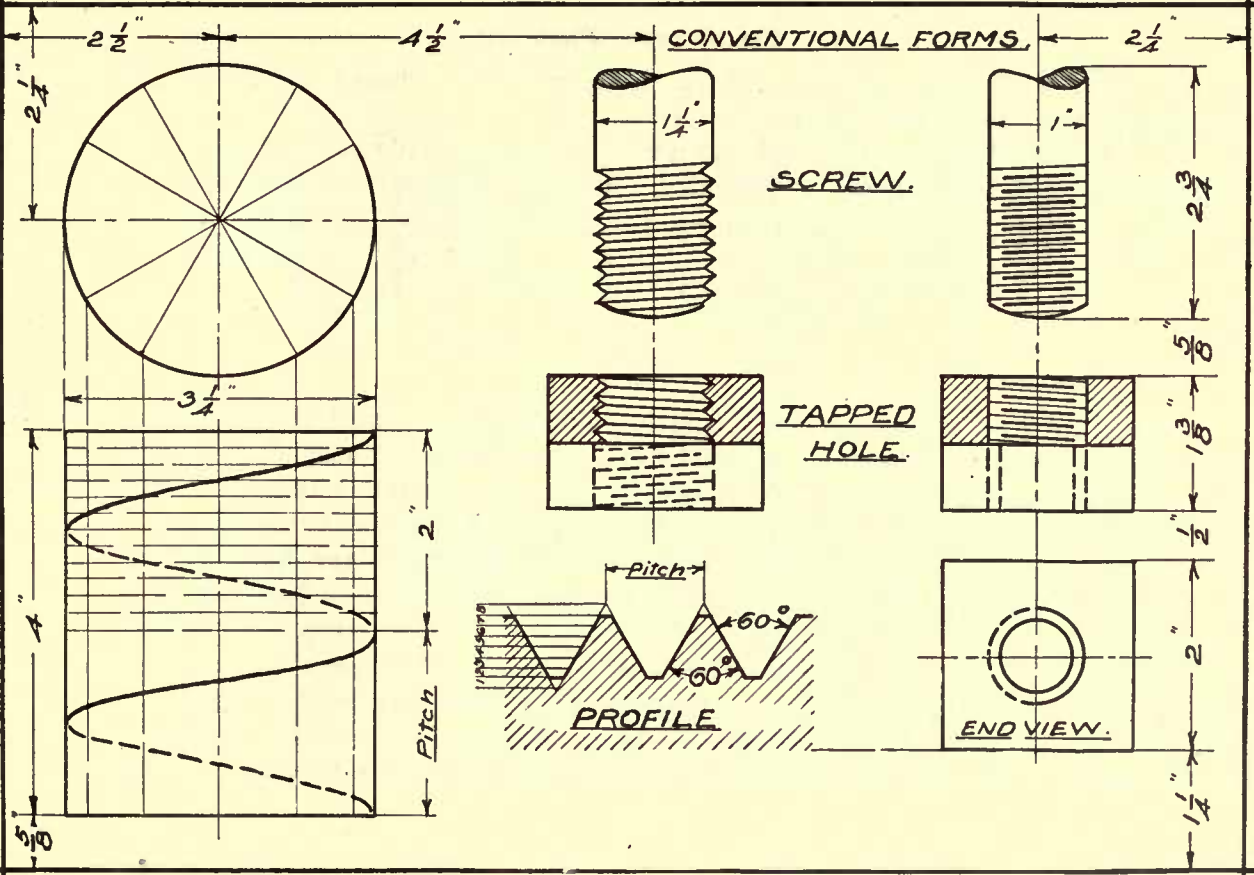

Specification—Plate 48A.

1. Draw a 1" hexagonal bolt and nut, U. S. Standard Thread, using the conventional method of representing the thread as indicated.
2. Draw a 1" square-head bolt and nut, U. S. Standard Thread, using the conventional method of representing thread as indicated. Scale 12"=1'.

For construction of bolt heads and nuts, see page 198.

Title:— MACHINE BOLTS

SCALE

DATE

NAME

There are two classes of bolts, namely: Machine Bolts and Carriage Bolts. Machine bolts are classed as rough or finished and have square or hexagonal heads. In the process of manufacturing rough bolts, rods of iron or steel are cut into pieces of definite lengths, according to the length of bolt desired. These pieces are heated at one end and placed in the jaws of a machine called a bolt header, leaving enough of the heated end projecting to form the head. The ram of the machine upsets and forms the heated end to the desired shaped head. A thread is cut on the other end of the bolt in a threading machine, with a threading tool called a die. Finished bolts are turned from hexagonal, square, or round bars. When turned from round bars it is necessary to machine the head to the desired shape. Nuts for the bolts are either punched from heavy sheet-metal or cut from metal bars of the proper shape. The holes are punched or drilled and are threaded with a tool called a tap.

PLATE 48A

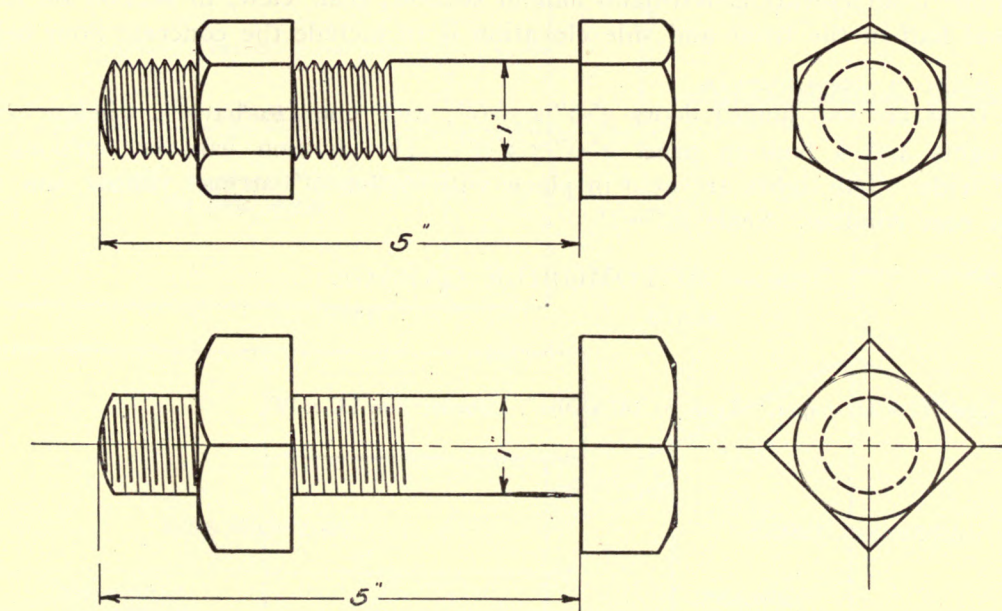

Specification—Plate 49.

Make a working drawing of a 11' x 16' Garage. Show the side elevation, left-hand half in section; front elevation, left-hand half in section; plan view, in section on line A-B. The sectional half in the front and side elevation is to include the concrete floor below the grade line.

In the front are two hinged doors 3'-6" x 7'-6"; each door to have a window with four 14" x 14" lights and a built-up panel 2'-6" x 3'-0". The division bars or mullions in window are 2" wide. The lights are held in place with $\frac{1}{2}$ " x $\frac{1}{2}$ " strips. Show the opening only for the rear window. Scale $\frac{1}{2}$ "=1'.

Title:— AUTOMOBILE GARAGE

SCALE

DATE

NAME

Note:—Use 15" x 22" paper. Trim to 14" x 20½". Border line 13" x 19".

19"

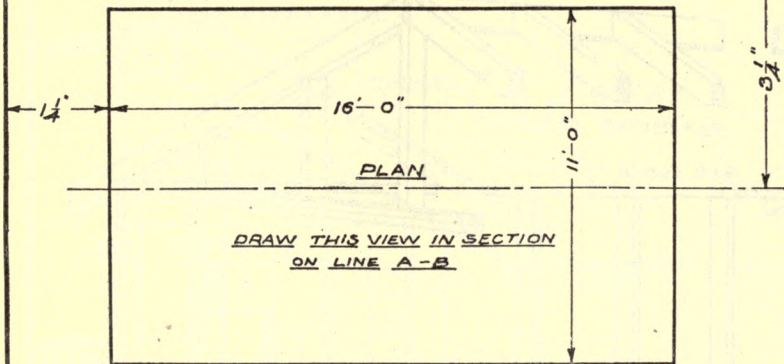

AUTOMOBILE GARAGE.

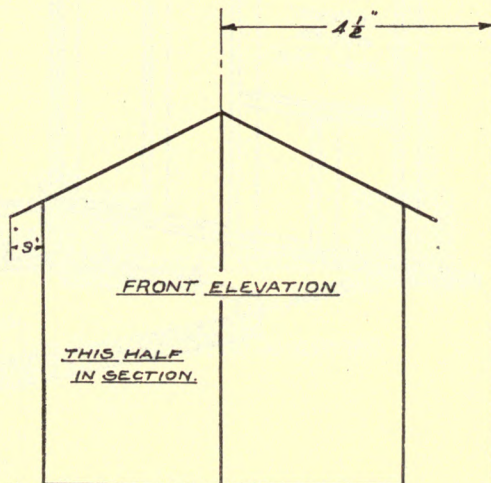
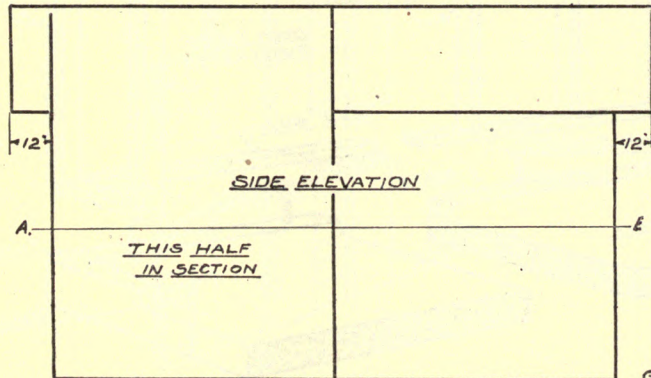

13"

PLATE 49 (Continued)

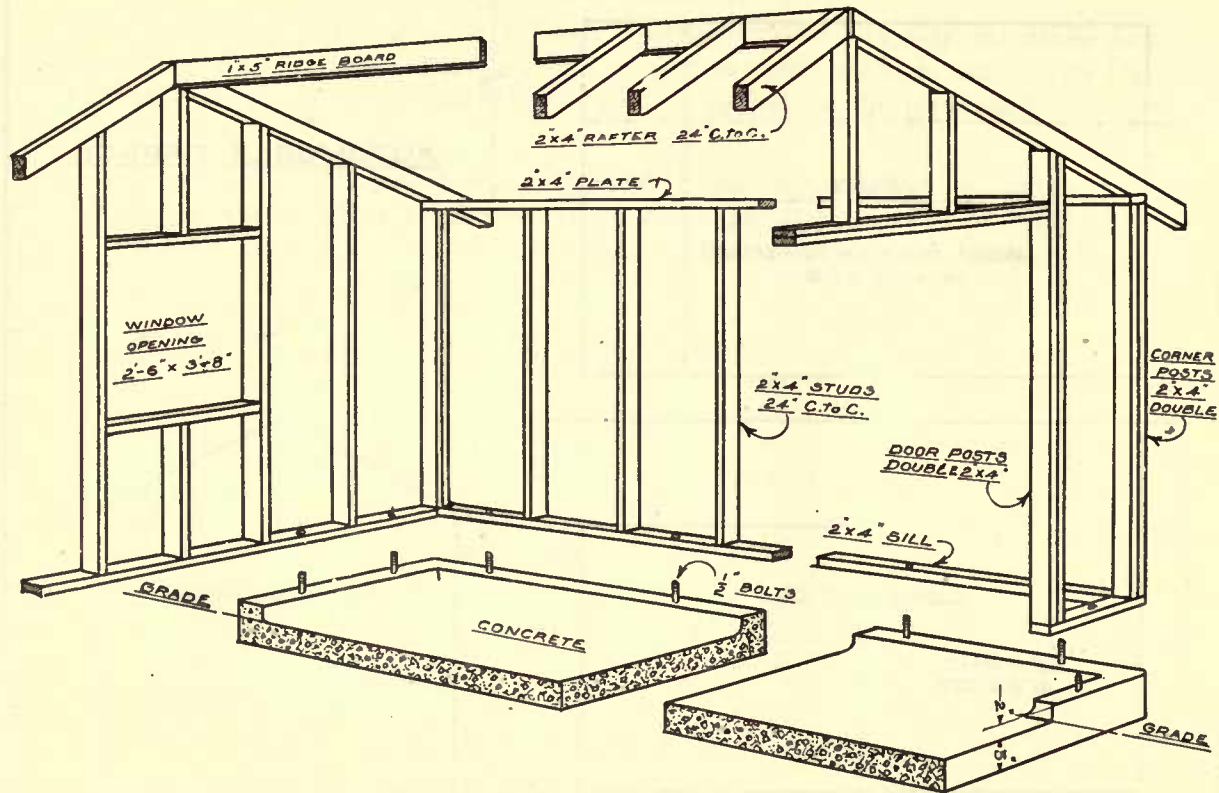
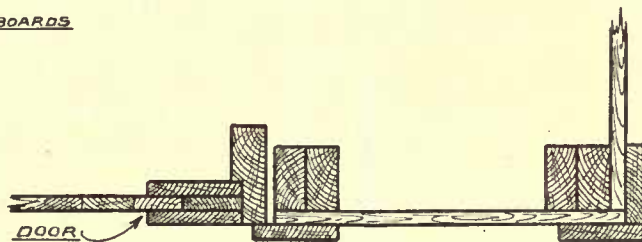
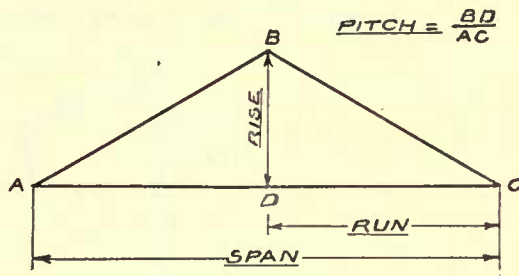
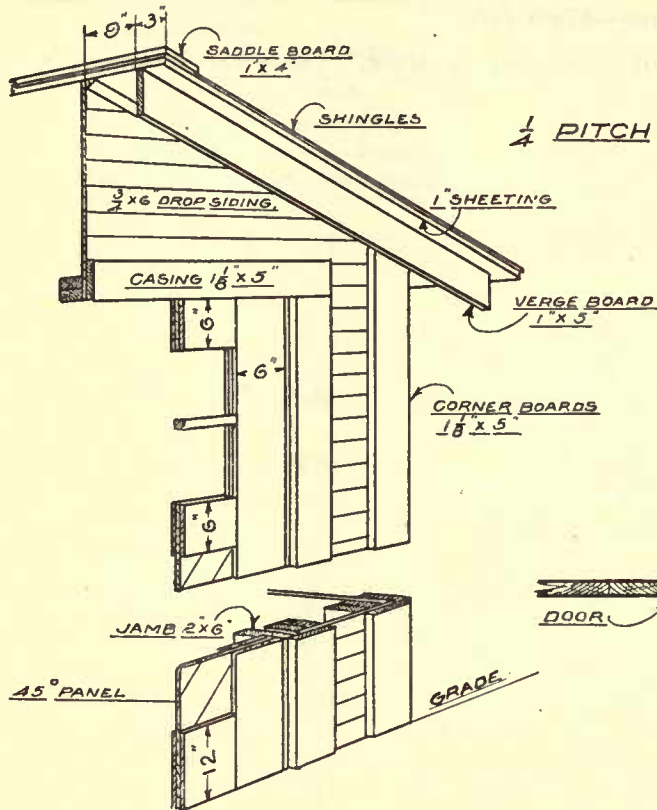

PLATE 49 (Continued)



Section through jamb & corner

Specification—Plate 49A.

Make a drawing of the Cornice and Sill to a suitable scale. Pitch $\frac{1}{3}$. Shingles $4\frac{1}{2}$ " to weather.

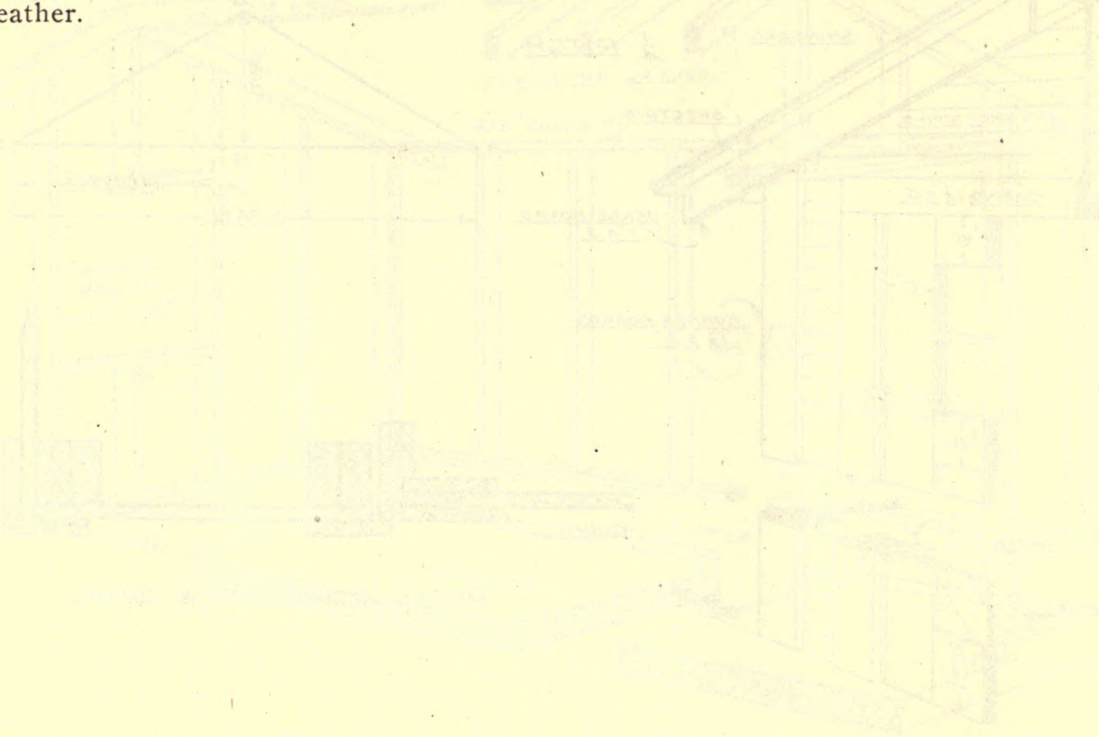

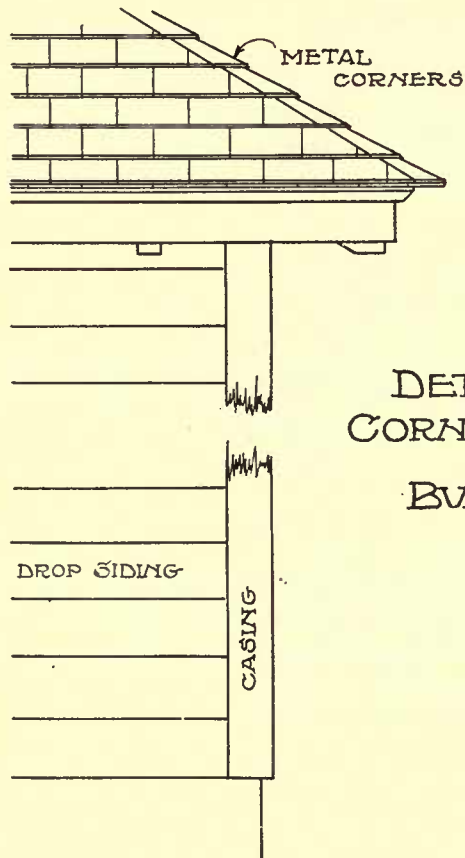

DETAILS of
CORNICE AND SILL
FOR
BUNGALOW

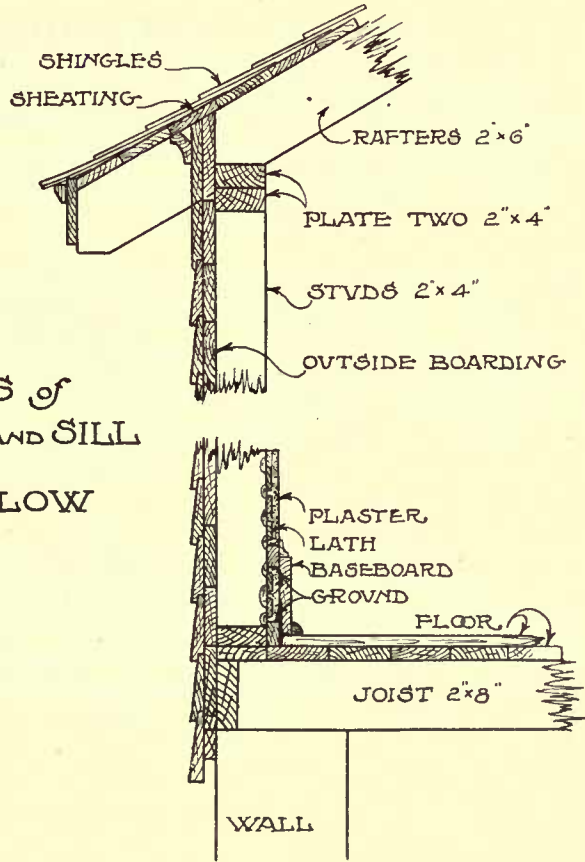

GEOMETRIC PROBLEMS.

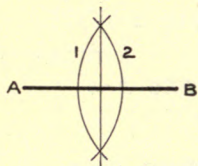

Prob. 1—To bisect a line as AB. With centers A and B, and any radius greater than one-half AB, draw arcs 1 and 2. Thru the points of intersection of these arcs draw a line. The line will bisect the line AB.

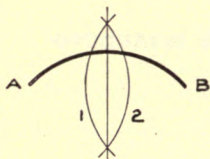

Prob. 2—To bisect the arc of a circle as AB. With centers A and B, draw intersecting arcs 1 and 2. Draw a line thru the points of intersection of these arcs. The line will bisect the arc AB.

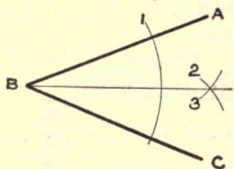

Prob. 3—To bisect an angle as ABC. From B with as large a radius as is possible, draw arc 1. From its point of intersection with AB and CB, draw arcs 2 and 3. A line drawn thru B and intersection of arcs 2 and 3, will bisect the given angle.

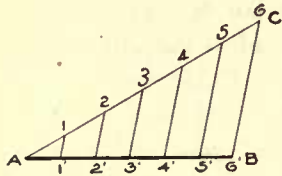

Prob. 4—To divide a line as AB into any number of parts. Let the required number of divisions be six. Draw AC at any angle with AB, and lay off six equal spaces of any length. Connect last point, 6, with B and draw lines parallel to this line thru the other points intersecting AB in points 1', 2', 3', 4' and 5' which determine the required divisions.

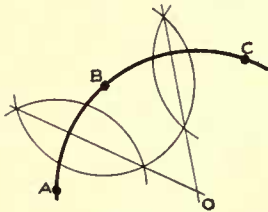

Prob. 5—Given: Three points A, B and C, not in the same straight line. Required: To draw an arc passing thru these points. With A and B as centers and any radius greater than one-half AB, describe intersecting arcs. With B and C as centers describe similar arcs. Draw lines thru intersections of these arcs. The point of intersection of these lines at O is the center for arc passing thru A, B, and C.

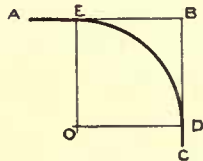

Prob. 6—Given: Lines AB and CB at right angles to each other. Required: To draw an arc of a given radius tangent to these lines. Draw line DO parallel to AB with distance EO equal to given radius. Draw line EO parallel to CB with distance DO equal to given radius. Point O is center of arc and D and E are the points of tangency.

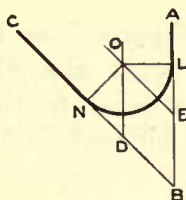

Prob. 7—Given: Lines AB and CB which are not at right angles to each other. Required: To draw an arc of a given radius tangent to these lines. Draw line DO parallel to AB with distance LO equal to given radius. Draw line EO parallel to CB with distance NO equal to given radius. Point O is center of arc and L and N are the points of tangency.

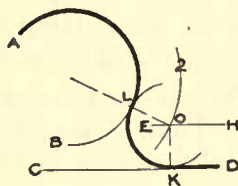

Prob. 8—Given: Any straight line CD and any arc AB. Required: To draw an arc of a given radius tangent to line CD and arc AB. Draw line EH parallel to CD with distance KO equal to given radius. From center of arc AB and with radius of arc AB, plus radius of given arc, describe arc 2 passing thru EH. Point O is center of arc, tangent to AB and CD. L and K are the points of tangency.

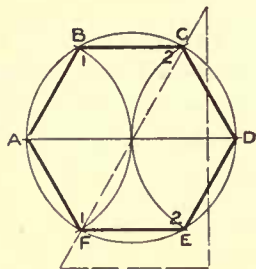

Prob. 9—Given: A circle of any diameter. Required: To inscribe a hexagon within it. Draw a diameter as AD. With A and D as centers and radius equal to that of circle, draw arc 1, 1 and 2, 2. Connect points of intersection A, B, C, D, E, and F to form required hexagon.

Draftsman's method: Draw horizontal diameter AD with T-square. With 30° , 60° triangle draw line passing thru center as illustrated by dotted lines, locating points C and F. In a similar manner locate points B and E and connect points with use of 30° , 60° triangle to form sides of hexagon.

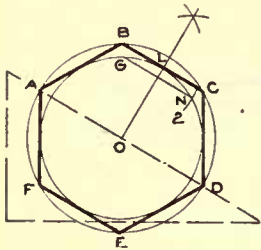

Prob. 10—Given a circle of any diameter. Required: To circumscribe a hexagon about it. Draw a diameter as BE. With point G as center and radius equal to that of given circle, describe arc 2. Bisect the arc GLN and thru L draw BC parallel to GN. With O as center and radius BO, describe circle BDF. In this circle inscribe a hexagon.

Draftsman's method: With 30° - 60° triangle draw diameters BE, AD and CF as illustrated by dotted lines. With same triangle draw sides AB and ED, BC and FE, AF and CD, each tangent to the given circle.

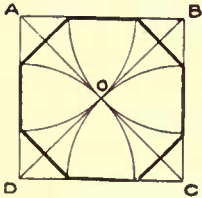

Prob. 11—To draw an octagon within a given square. Draw diagonals in square. With A, B, C, and D as centers, strike arcs passing thru center and intersecting sides of square. Connect intersections with straight lines to form octagon.

HOW TO SHARPEN A PENCIL.

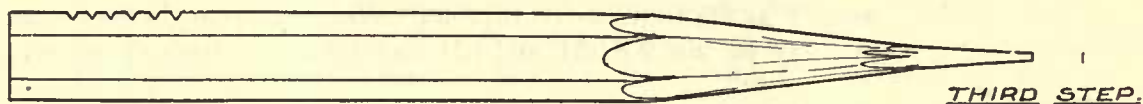
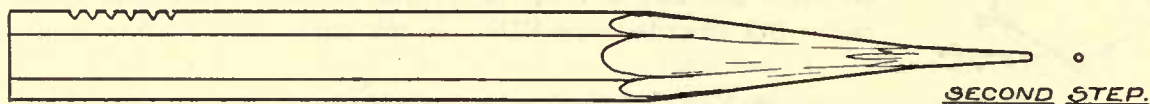
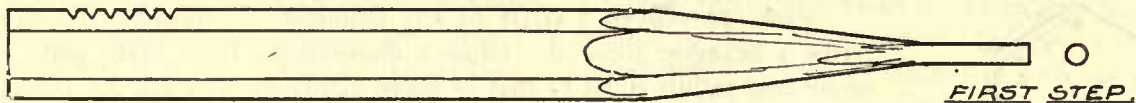

NOTCH
TO INDICATE
DEGREE OF
HARDNESS

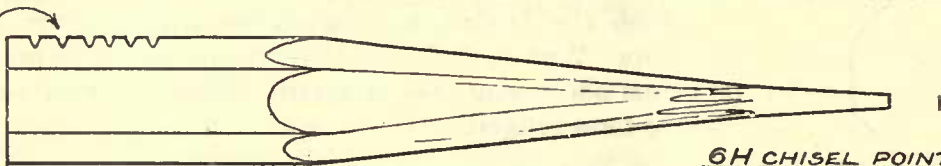

6H CHISEL POINT
BEST SUITED FOR LAYOUT OF WORK.

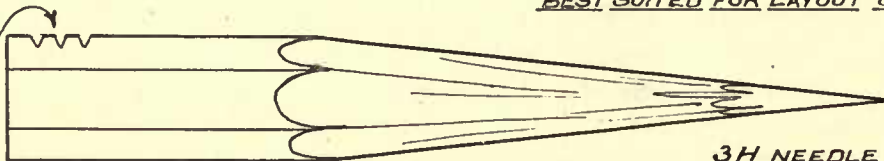

3H NEEDLE POINT
BEST SUITED FOR DIMENSIONING
AND LETTERING

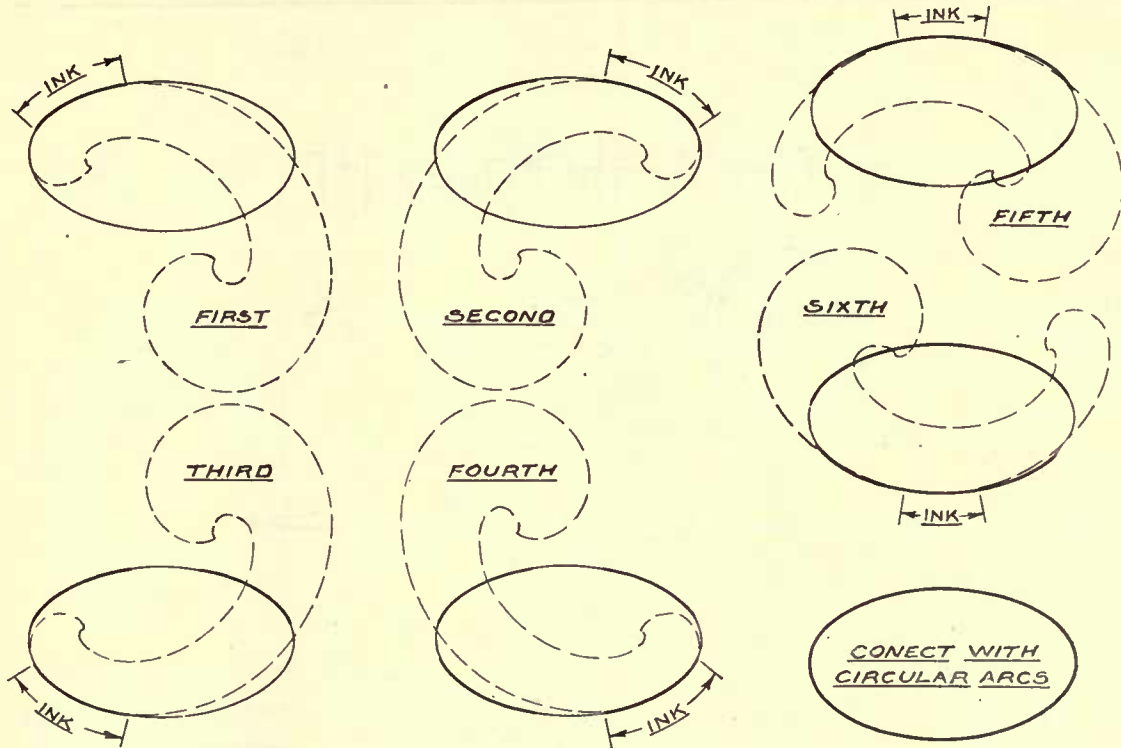

First draw the ellipse free hand as carefully and smooth as possible. Then apply that section of the curve which best coincides with the largest portion of the pencil line. It is best not to ink the full length of line matched by the curve, but move curve to a new position.

DIMENSIONING

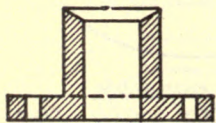
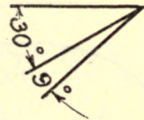
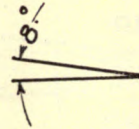
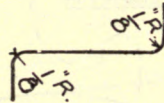
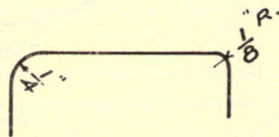
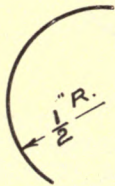
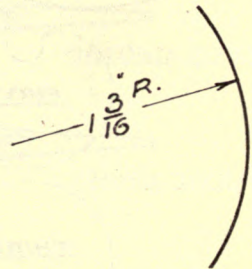
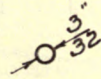
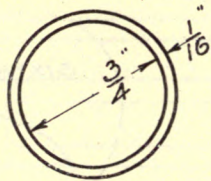
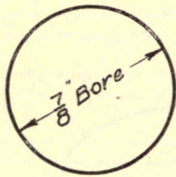
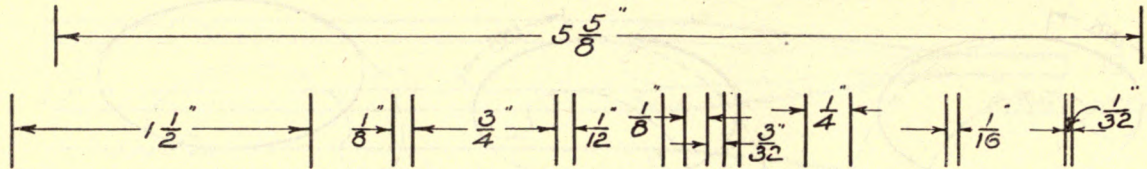

Finish all over

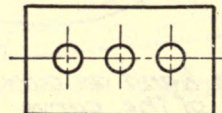
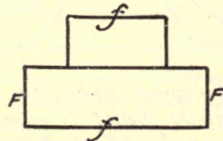

Drill 3 holes $\frac{7}{16}''$

WRONG

WRONG

WRONG

RIGHT

Make arrow heads like this

METHODS OF INDICATING FINISH.

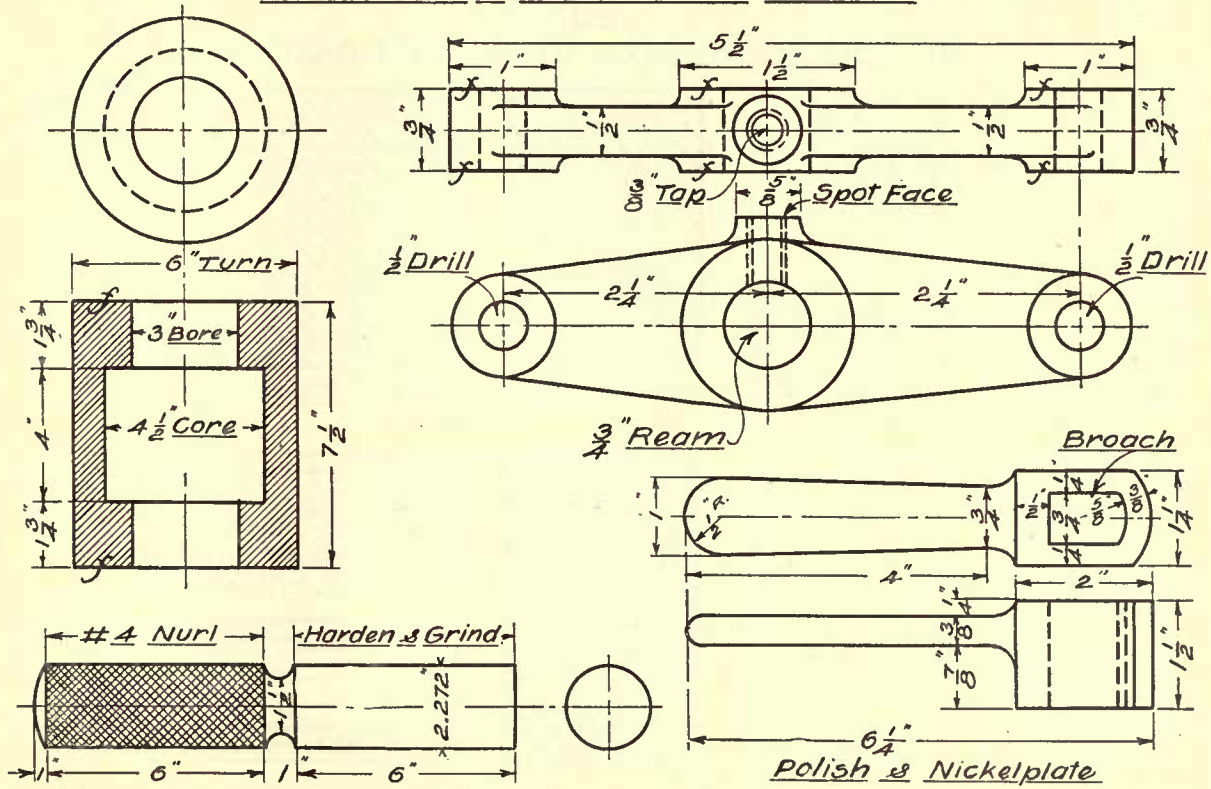

CONVENTIONAL SECTIONS
AND
REPRESENTATIONS OF MATERIALS

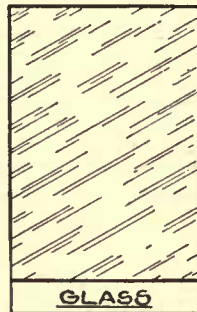
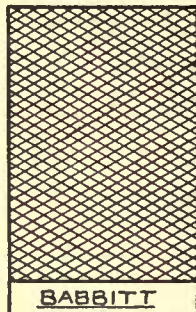
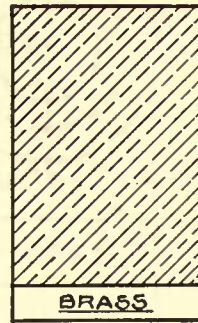
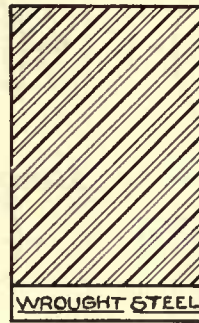
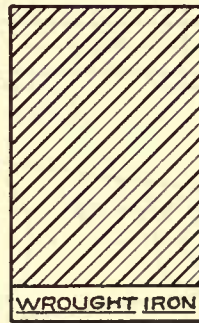
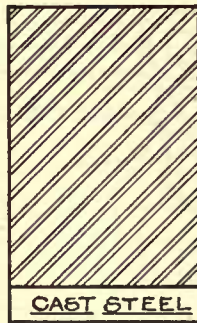
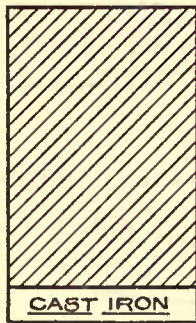

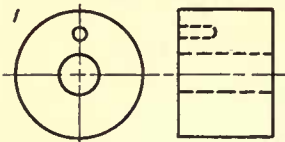
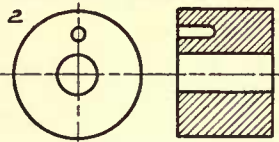
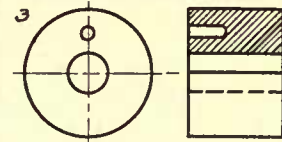
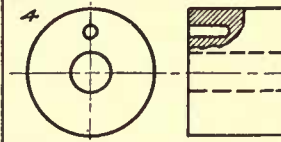
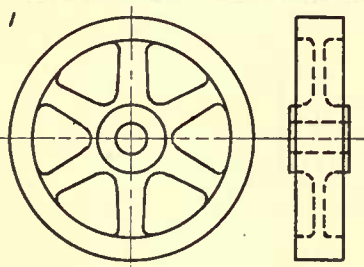
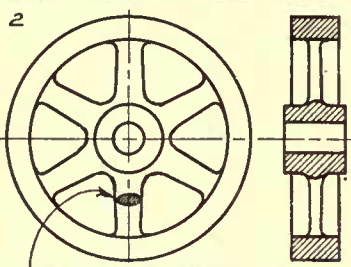
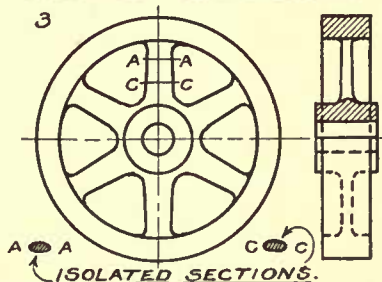
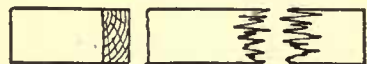
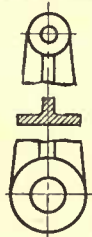
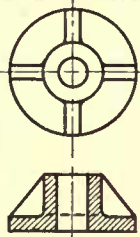
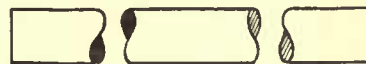
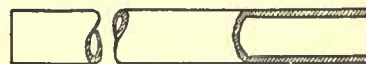
CAST IRON COLLAR.**FRONT VIEW. END VIEW.****END VIEW IN SECTION.****END VIEW HALF IN SECTION.****END VIEW PARTIAL SECTION.****CAST IRON FLY WHEEL.****SIDE VIEW IN SECTION.****SIDE VIEW HALF IN SECTION.****REVOLVED SECTION.****ISOLATED SECTIONS.****SQUARE OR RECTANGULAR METAL RODS.****SQUARE OR RECTANGULAR WOOD.****BROKEN SECTION.****RIBBED PLATE SECTIONED.****REVOLVED SECTIONS.****SOLID ROUND METAL.****HOLLOW ROD OR PIPE.**

U.S. STANDARD BOLTS AND NUTS (FINISHED)

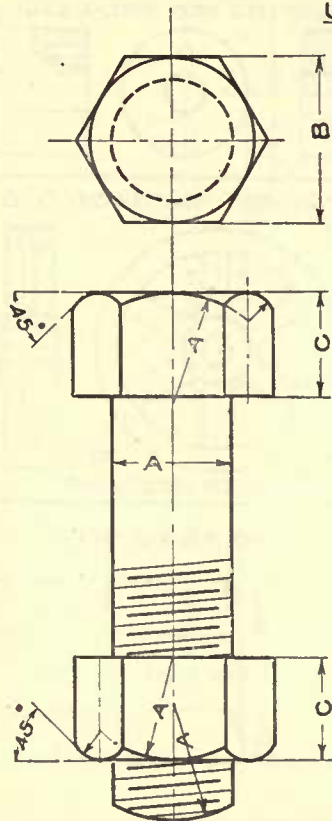

A = DIAMETER OF BOLT	B = DISTANCE ACROSS FLAT	C = THICKNESS OF HEAD & NUT	THREADS PR. INCH
$\frac{1}{4}$	$\frac{7}{16}$	$\frac{3}{16}$	20
$\frac{5}{16}$	$\frac{17}{32}$	$\frac{1}{4}$	18
$\frac{3}{8}$	$\frac{5}{8}$	$\frac{5}{32}$	16
$\frac{7}{16}$	$\frac{23}{32}$	$\frac{3}{8}$	14
$\frac{1}{2}$	$\frac{13}{16}$	$\frac{7}{16}$	12
$\frac{9}{16}$	$\frac{29}{32}$	$\frac{1}{2}$	12
$\frac{5}{8}$	1	$\frac{9}{16}$	11
$\frac{3}{4}$	$1\frac{3}{16}$	$\frac{11}{16}$	10
$\frac{7}{8}$	$1\frac{3}{8}$	$\frac{13}{16}$	9
1	$1\frac{9}{16}$	$\frac{15}{16}$	8
$1\frac{1}{8}$	$1\frac{3}{4}$	$1\frac{1}{16}$	7
$1\frac{1}{4}$	$1\frac{15}{16}$	$1\frac{3}{16}$	7

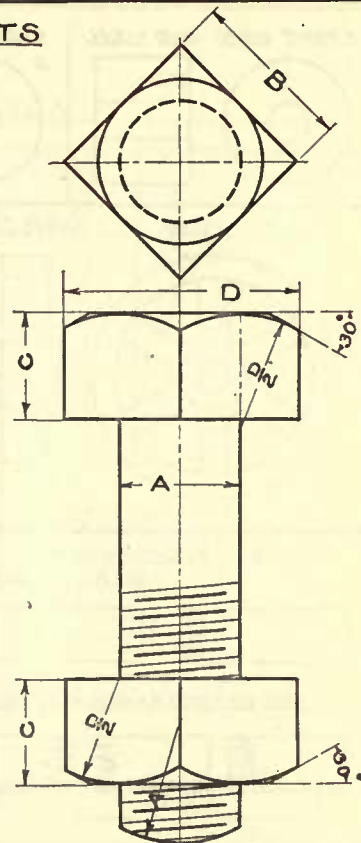

U.S. STANDARD SCREW THREAD

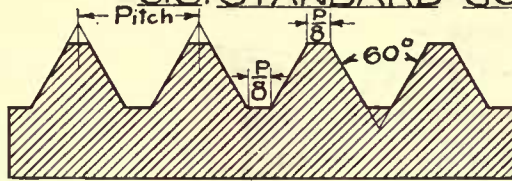

PROFILE OF THREAD

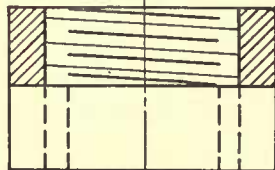
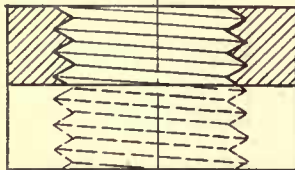
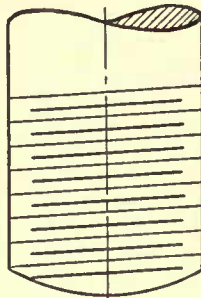
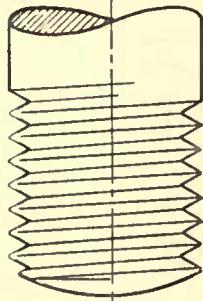

CONVENTIONAL REPRESENTATION

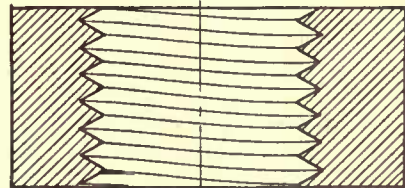
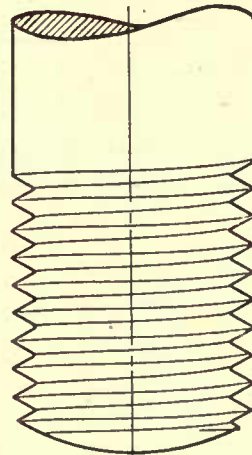

ACTUAL FORM
SHOWING HELICES

SQUARE THREAD AND ACME THREAD

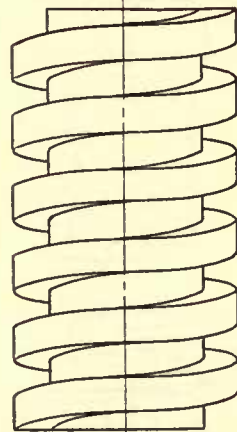
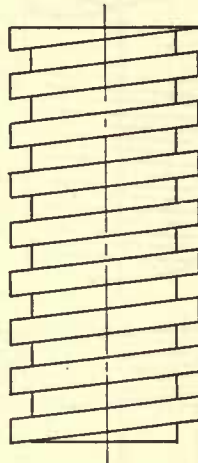
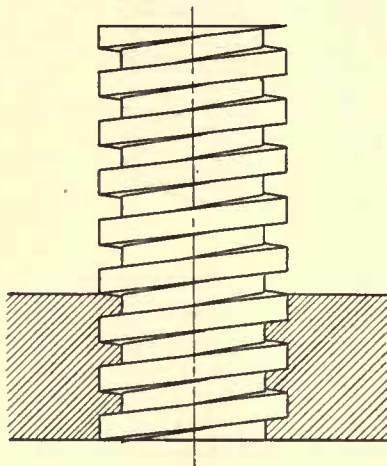
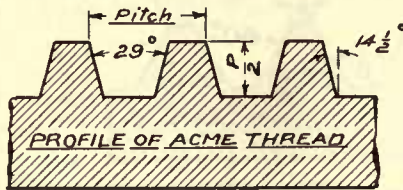
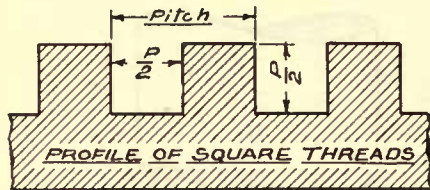

CONVENTIONAL REPRESENTATIONS

ACTUAL FORM
SHOWING HELICES

VARIOUS KINDS OF SCREWS



WOOD SCREW

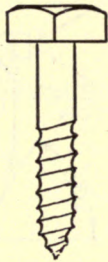

LAG SCREW

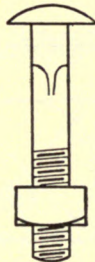

CARRIAGE BOLT

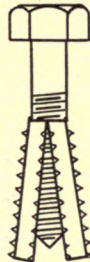

EXPANSION BOLT

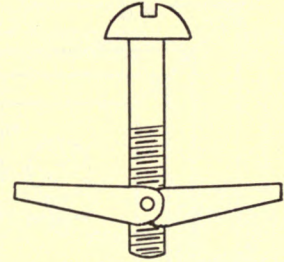

TOGGLE BOLT

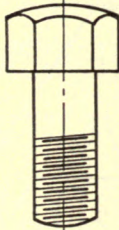

CAP SCREWS

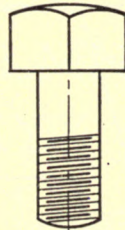
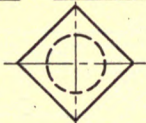

SET SCREWS

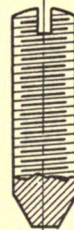

CABINET DRAWING ILLUSTRATED

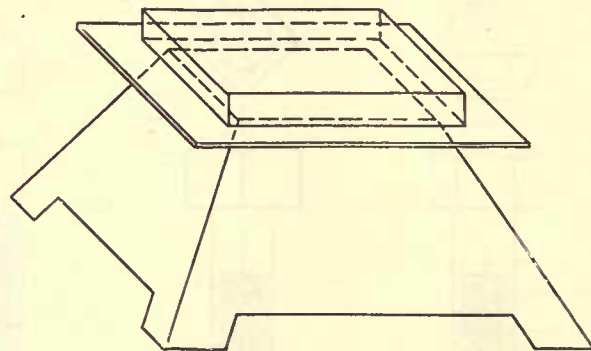
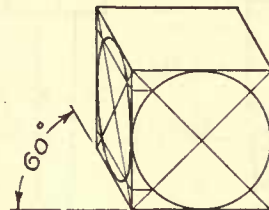
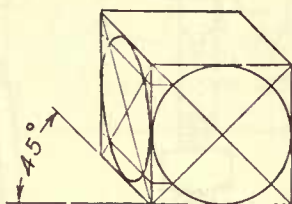
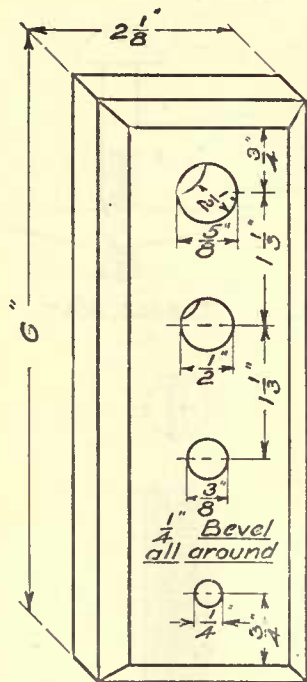

ARCHITECTURAL DETAILS

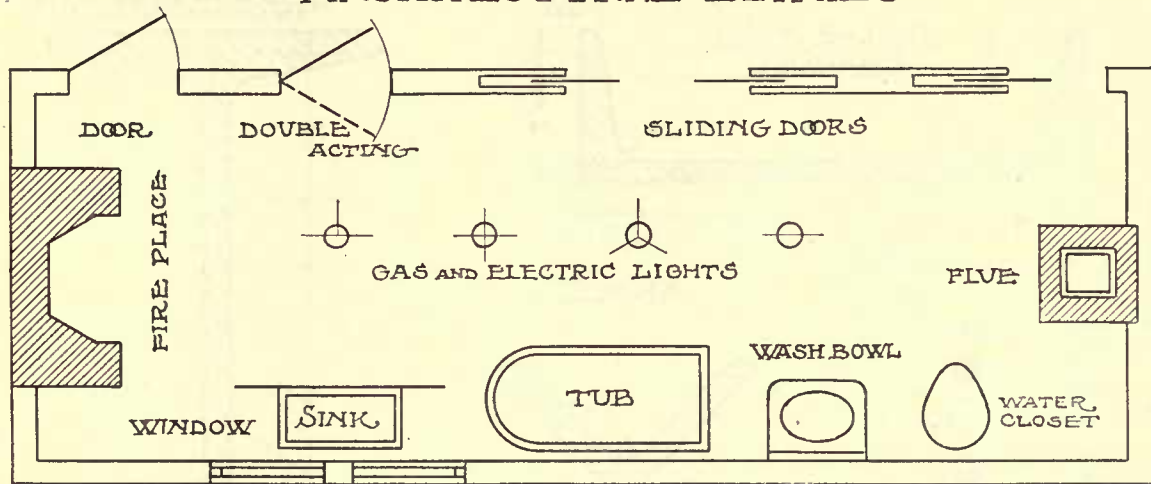

ABCDEFGHIJKLMNO

ABCDEFGHIJKLMNO

PQRSTUVWXYZ &

PQRSTUVWXYZ &

abcdefghijklmnopqrstuvwxyz &

STRUCTURAL STEEL FORM.

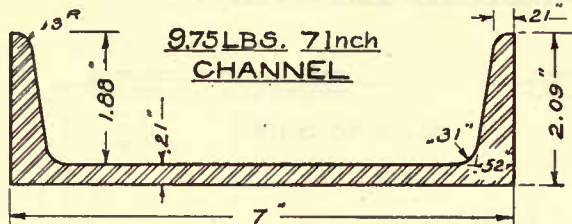

For details of standard steel forms see Cambria Steel Co's book.

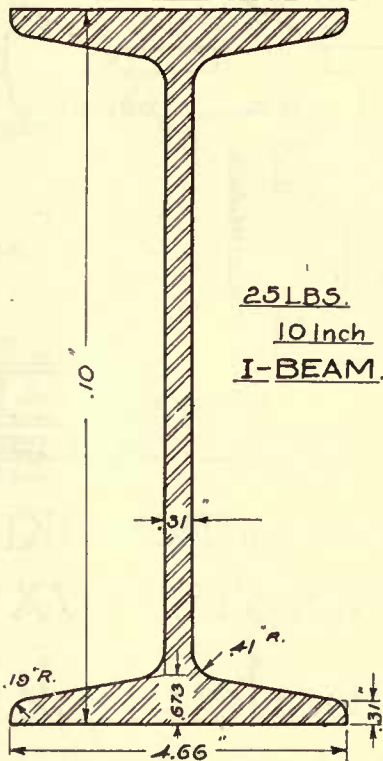

CONVENTIONAL SIGNS FOR RIVETING.

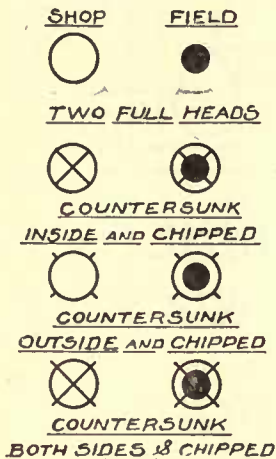

ANGLE

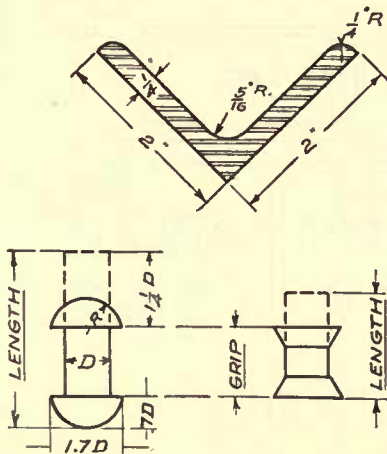

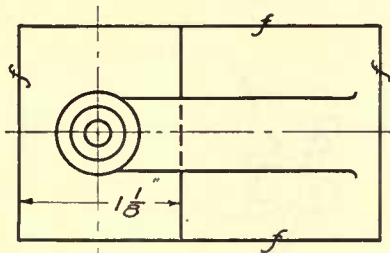
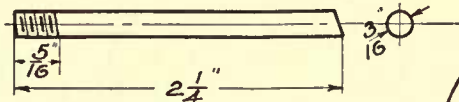
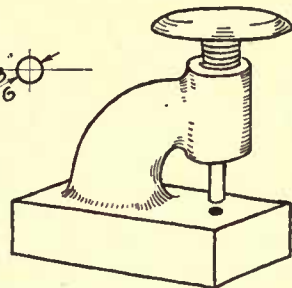
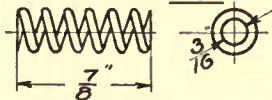
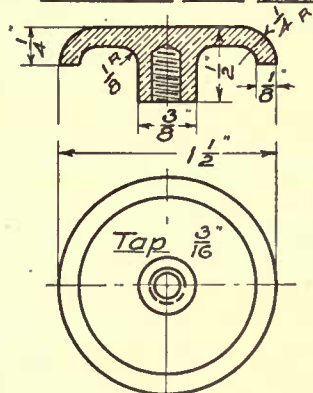
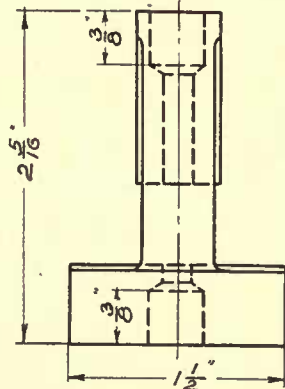
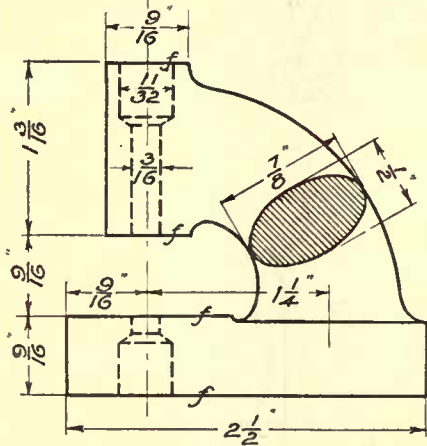
BASE C.Iron.PUNCH C.R. Steel.SPRING Brass Wire #17STRIKER Cast BrassPAPER PUNCH
SCALE *Sign* DATE

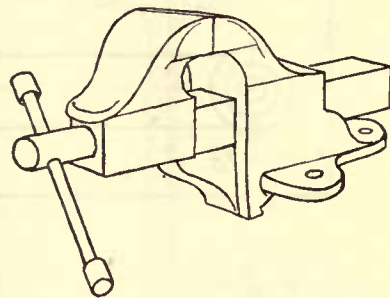
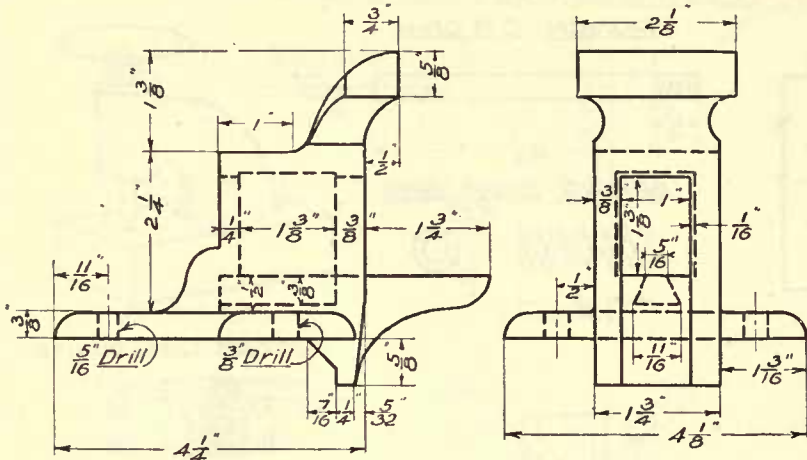

METALWORKING VISE
SCALE DATE

Sign

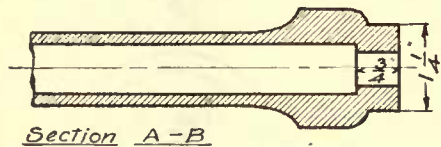

Section A-B

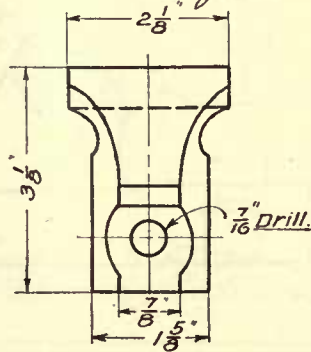
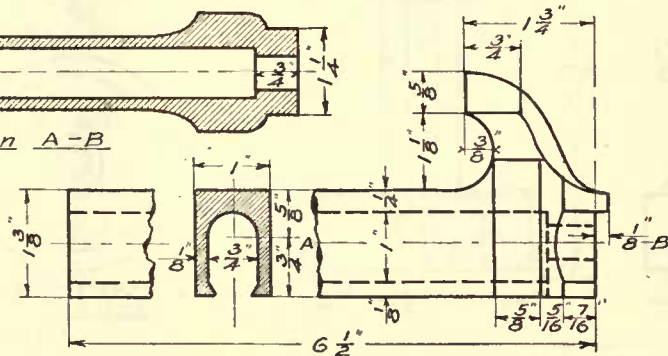

SCREW Mch. Steel. Finish all over.

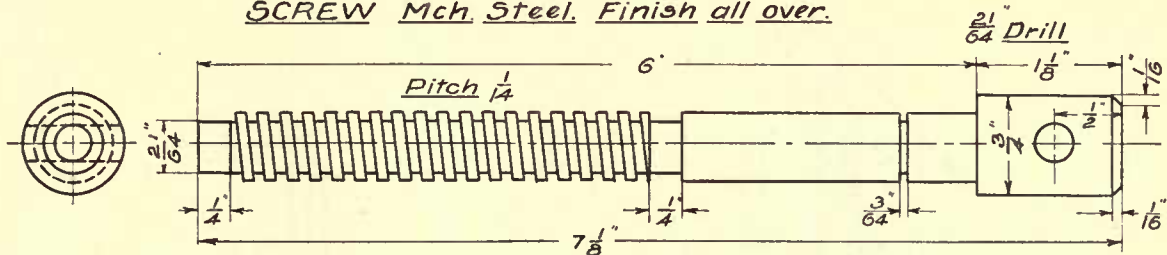

HANDLE Mch. Steel.

Finish all over.

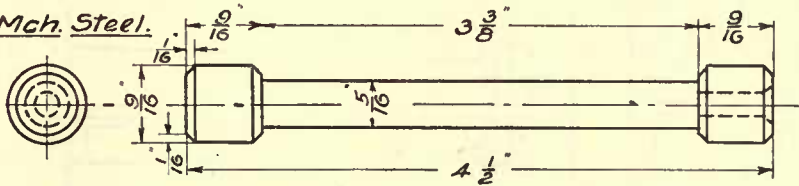

$\frac{11}{32}$ Drill

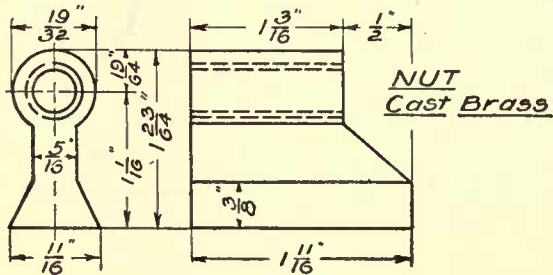

NUT
Cast Brass

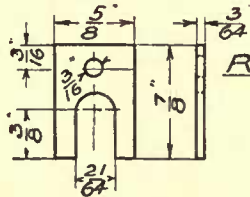

RETAINER
Brass

WISE DETAILS
SCALE DATE

Sign.

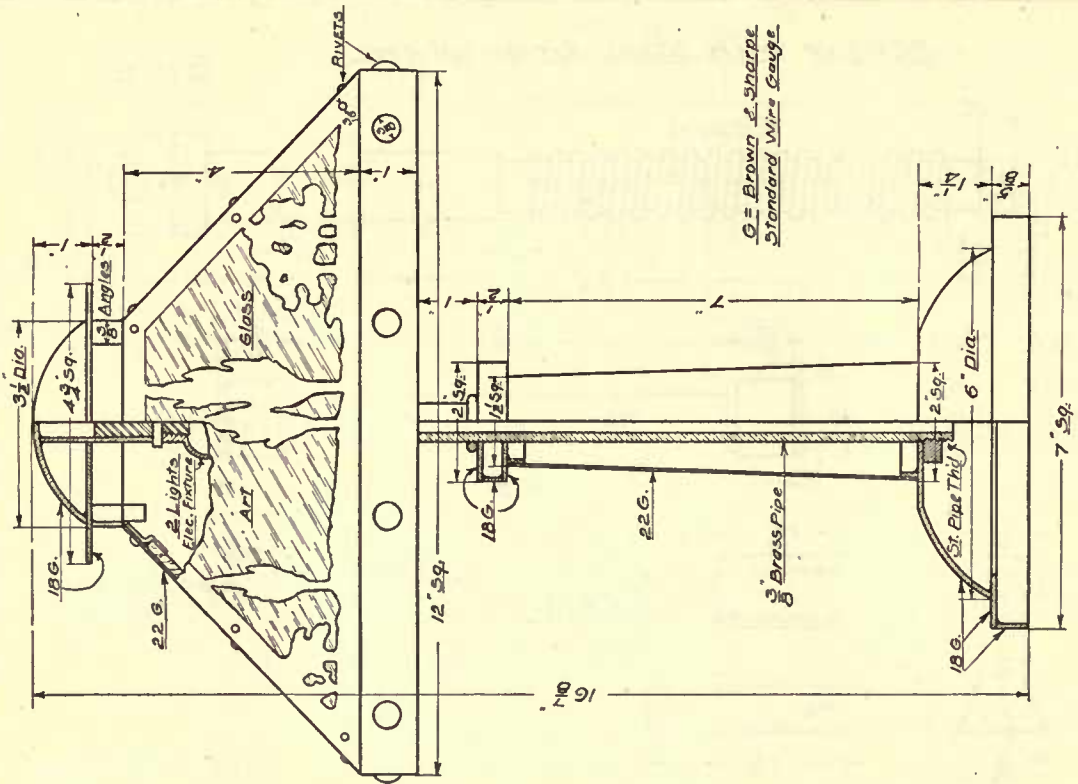
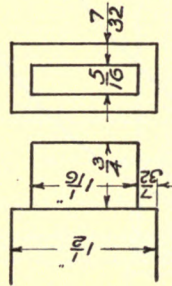
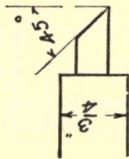
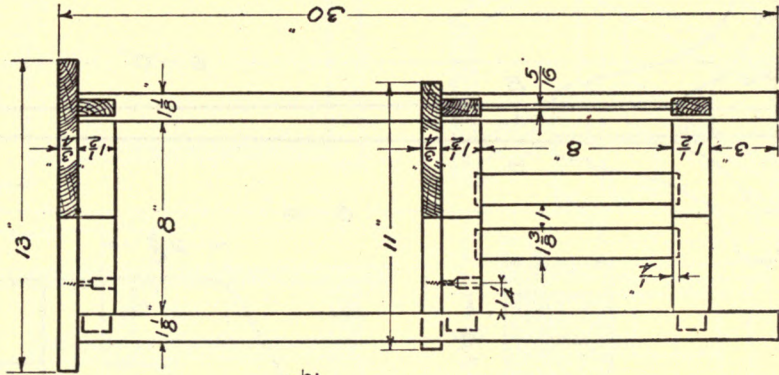
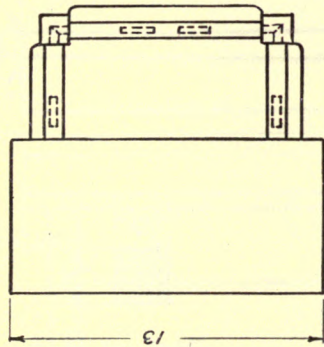

TABLE LAMP
 HAMMERED COPPER
 SCALE _____ NAME _____
 DATE _____



DETAIL OF TENON

FERN STAND

SCALE

DATE

Lyne

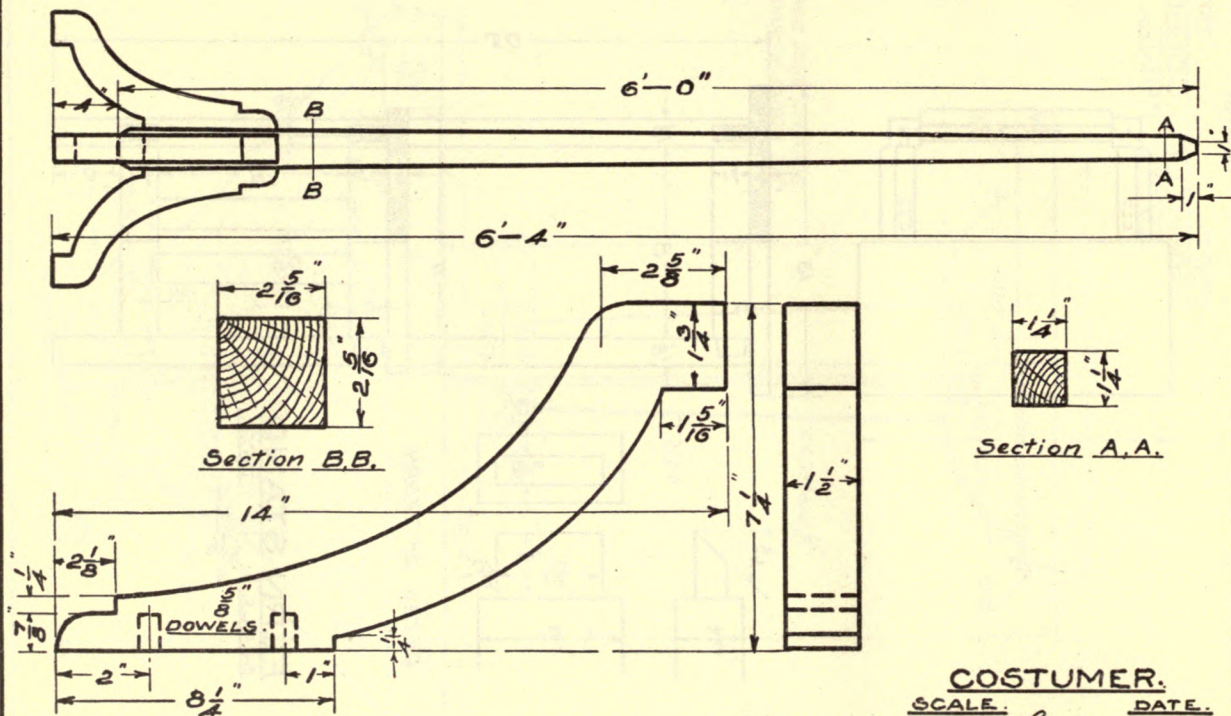

COSTUMER: _____
 SCALE: _____ DATE: _____

Sign

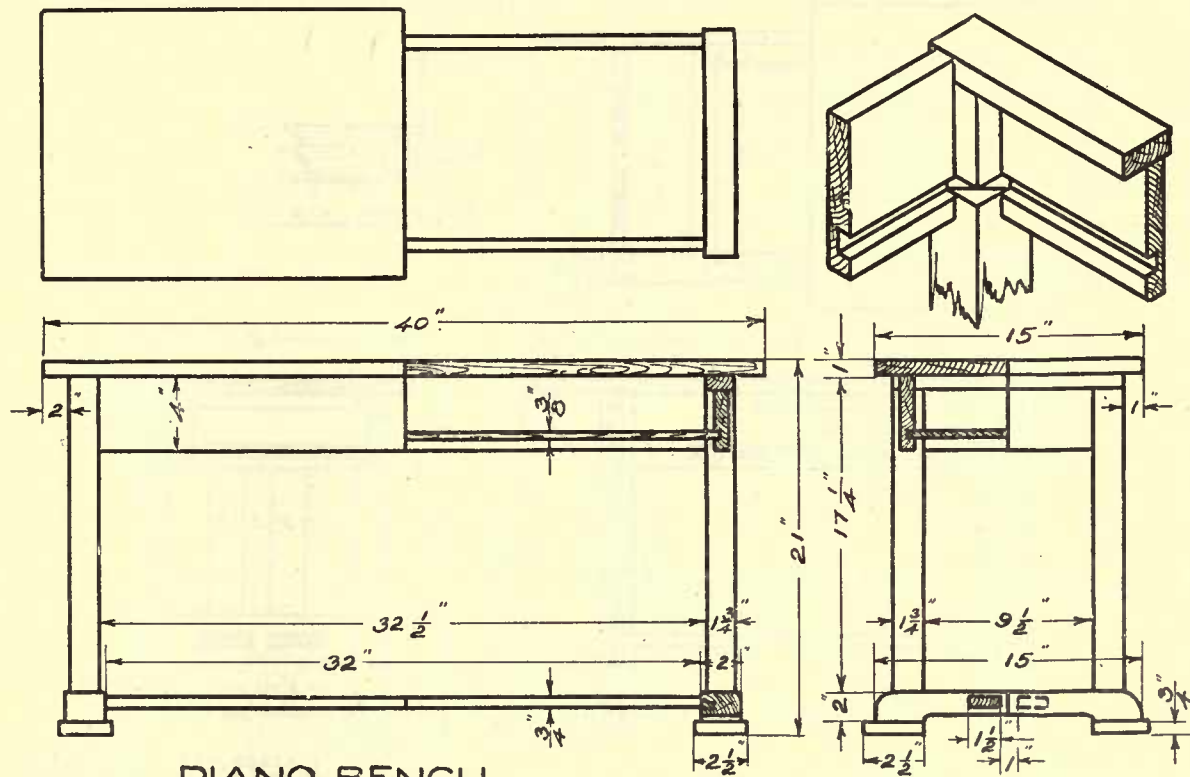

PIANO BENCH.
 SCALE. DATE.

Sign

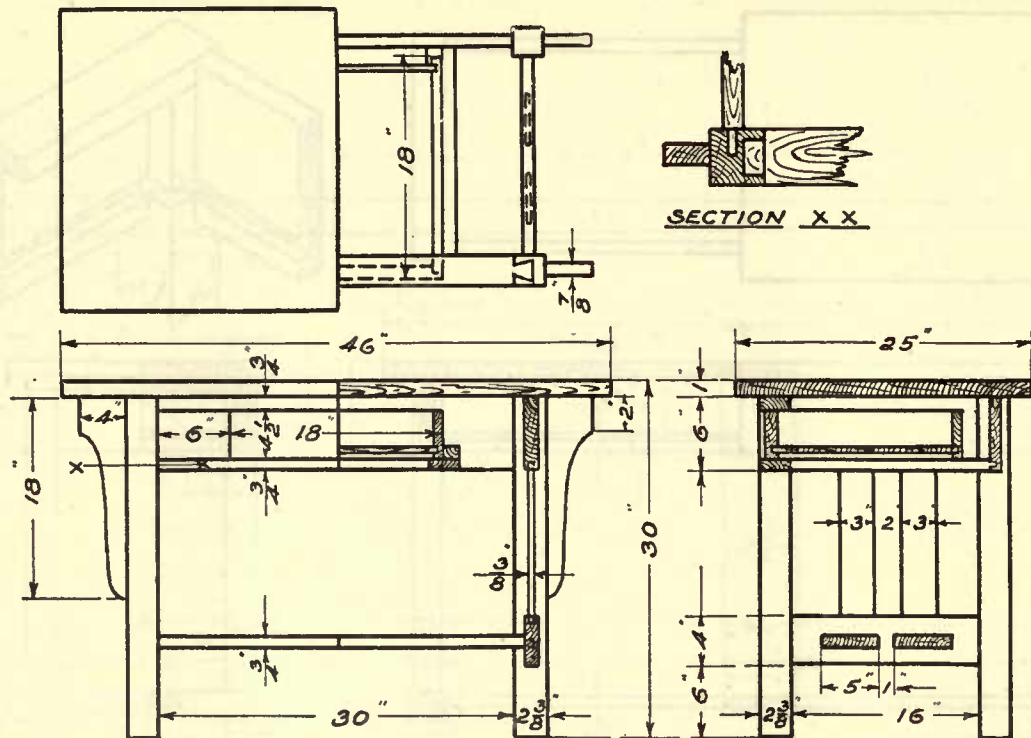

LIBRARY TABLE.
SCALE _____ **DATE.** _____

Sign

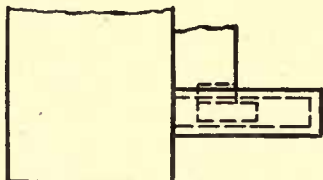

BILL OF MATERIAL, Q.T.W. OOK.

1	-	1 1/2	X	27	-	42	<u>TOP.</u>
1	-	1	X	11 1/2	-	30	<u>SHELF.</u>
2	-	1 1/2	X	5 3/4	-	23	<u>RAILS.</u>
2	-	1 1/2	X	3 3/4	-	25	<u>CLEATS.</u>
2	-	1 1/2	X	6 3/4	-	25	<u>LEGS.</u>
4	-	1 1/2	X	5	-	17 1/2	<u>SLATS.</u>
4	-	1 1/4	X	1 1/2	-	3 3/4	<u>SHELF SUPPORTS.</u>

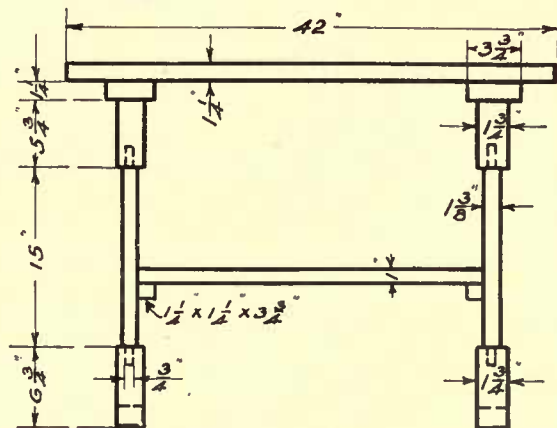
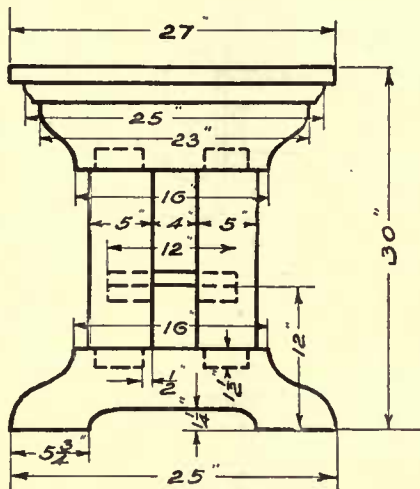

LIBRARY TABLE
 SCALE $\frac{1}{16} = 1''$ DATE.

Sign.

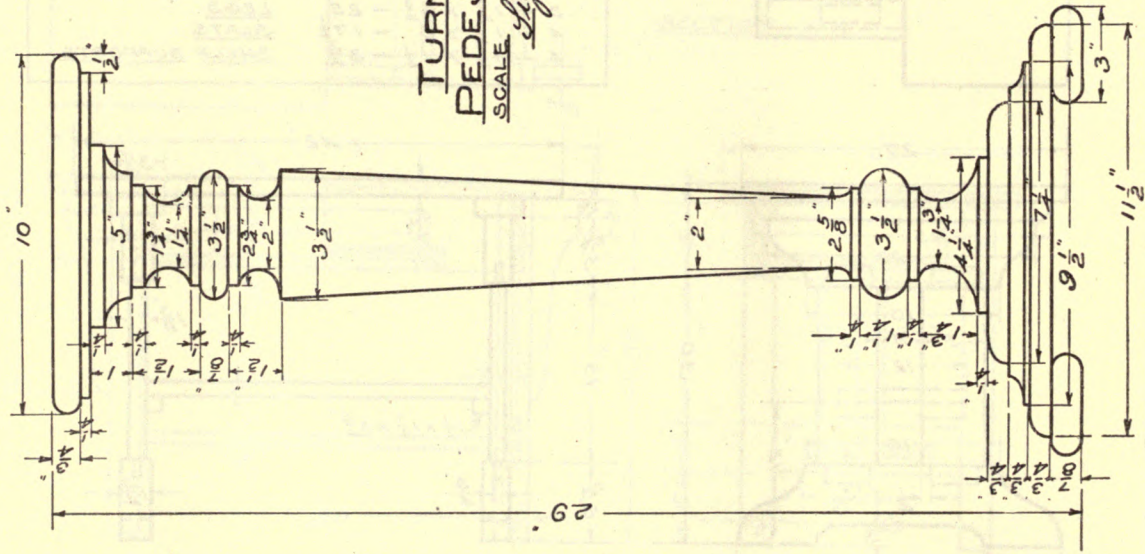

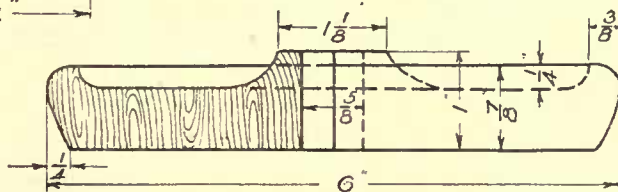
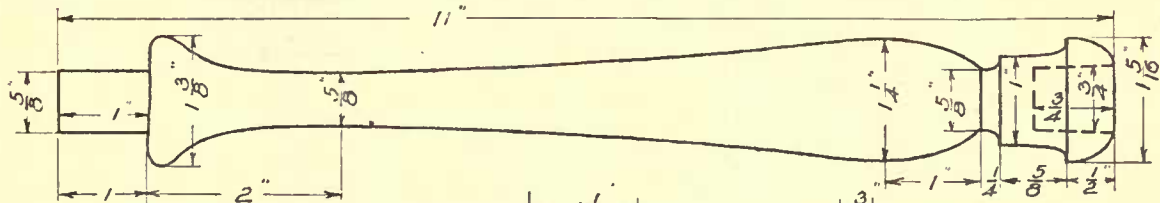
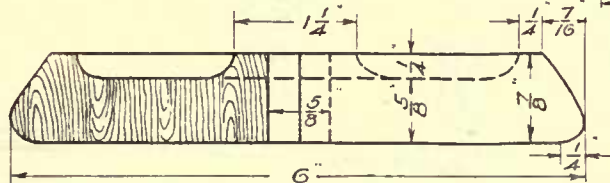
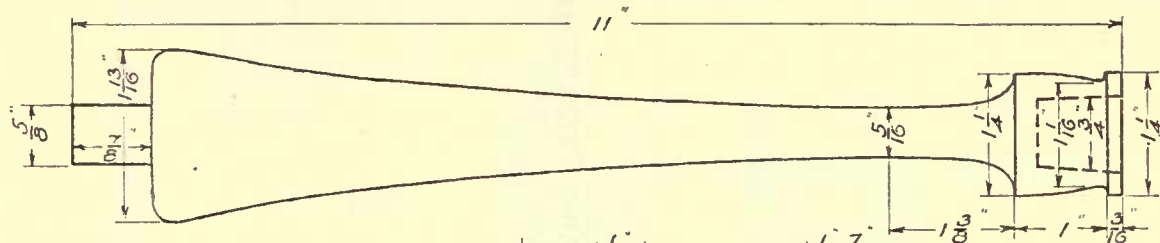

TURNED
CANDLE STICKS
SCALE 6"=1" DATE _____
NAME _____

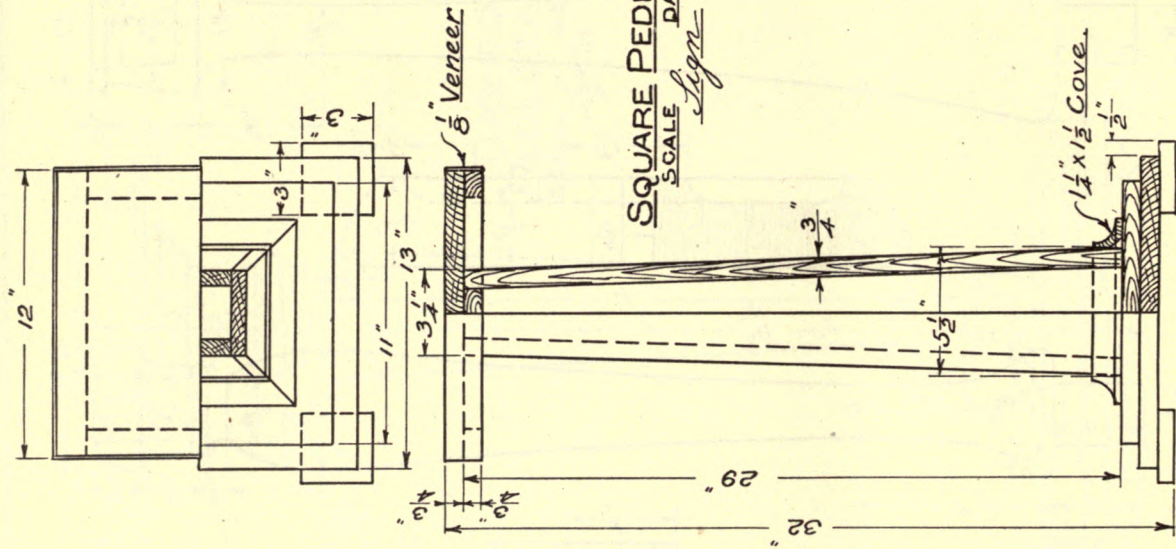

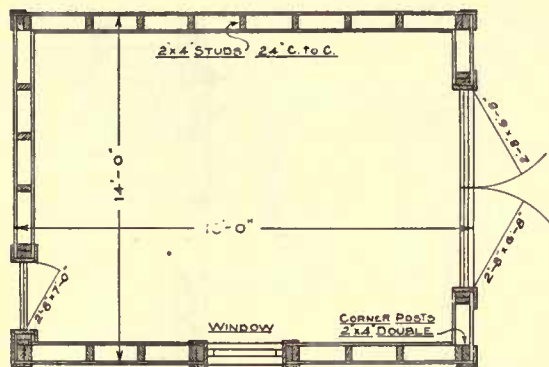

AUTOMOBILE GARAGE
 SCALE _____ DATE _____
 Sign _____

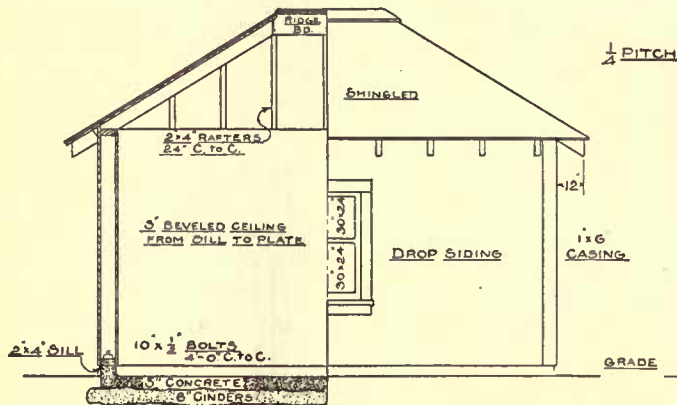

1/4 PITCH

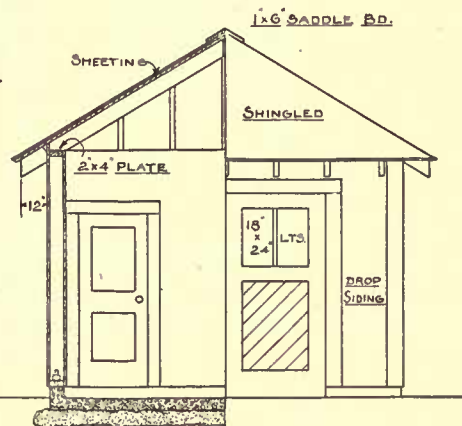

WINDOW DETAILS

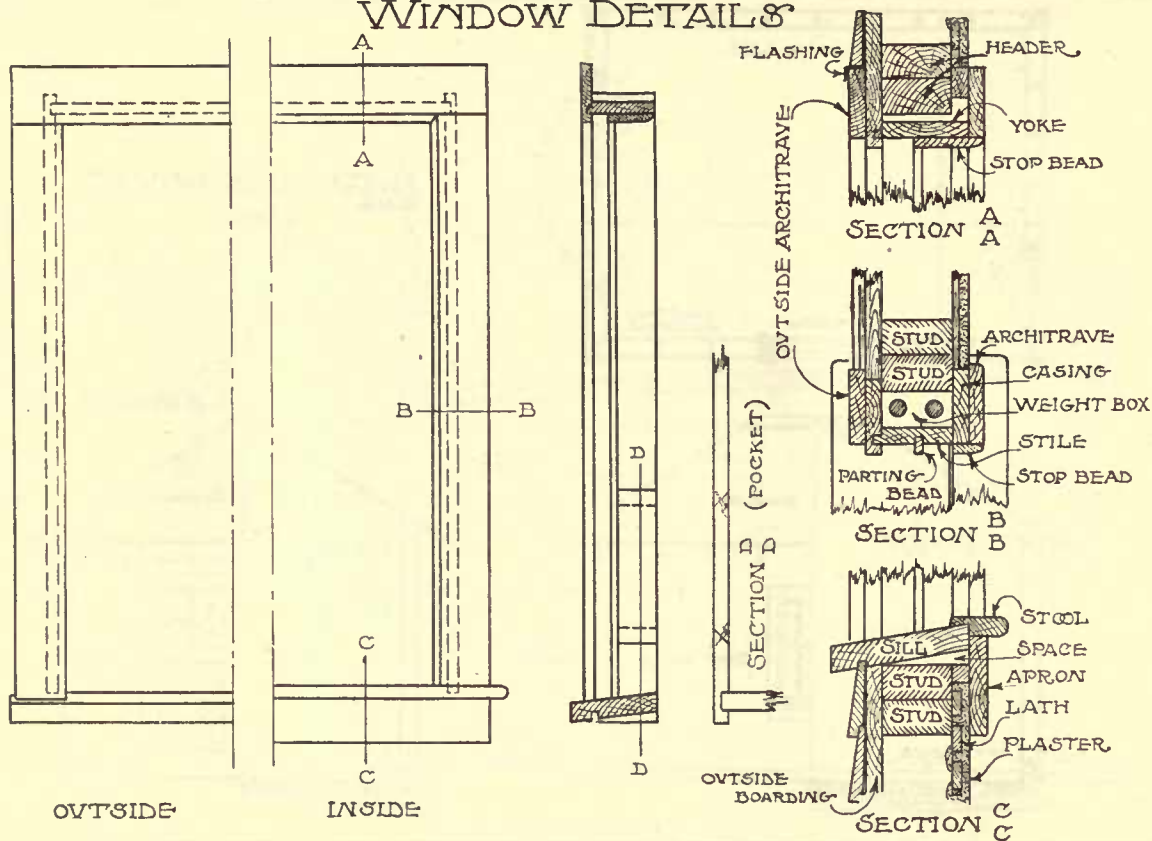

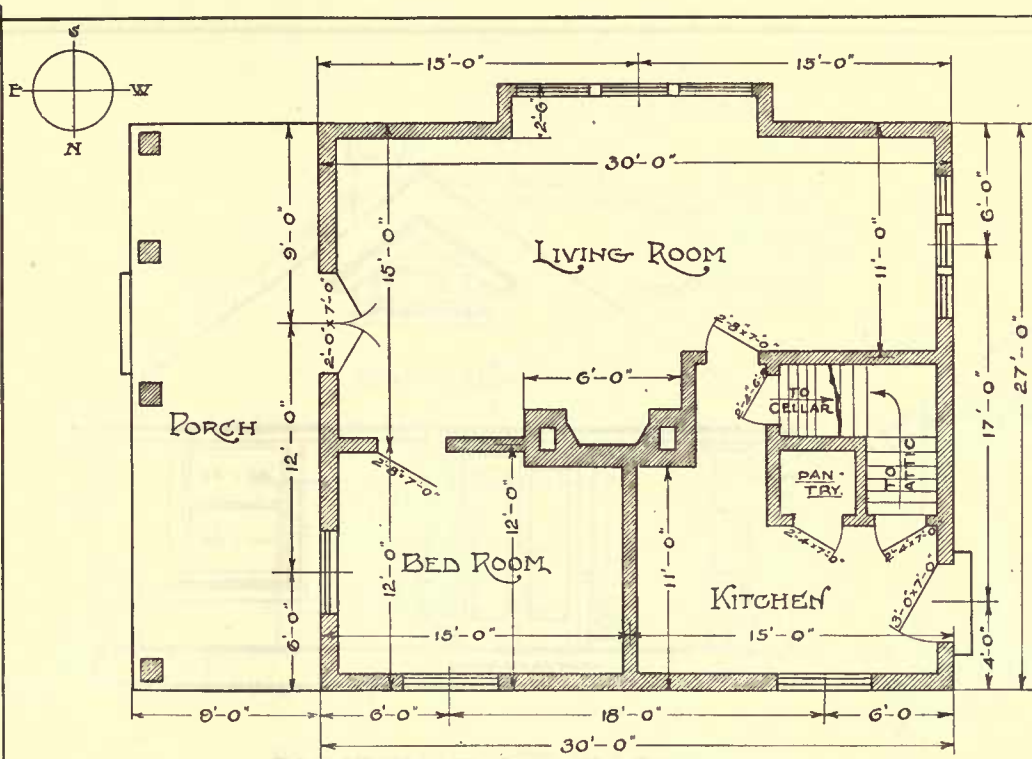

PLAN of SUMMER
COTTAGE,

SCALE =

FOR

DATE,

ARCHITECT

YEAR,

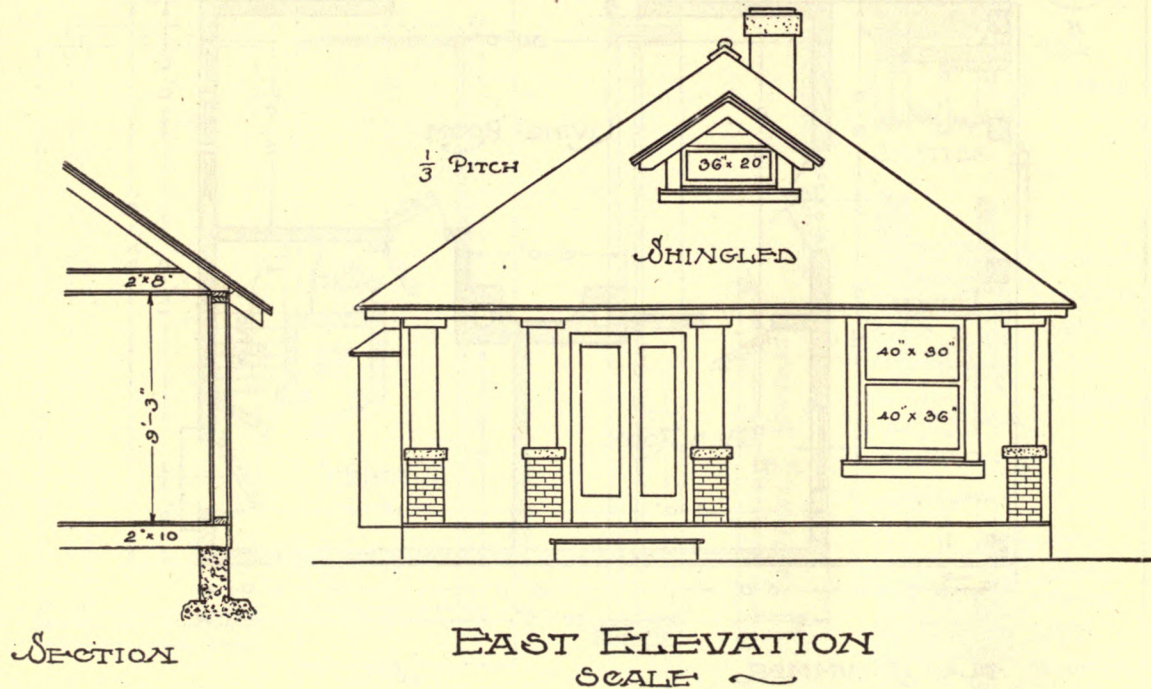

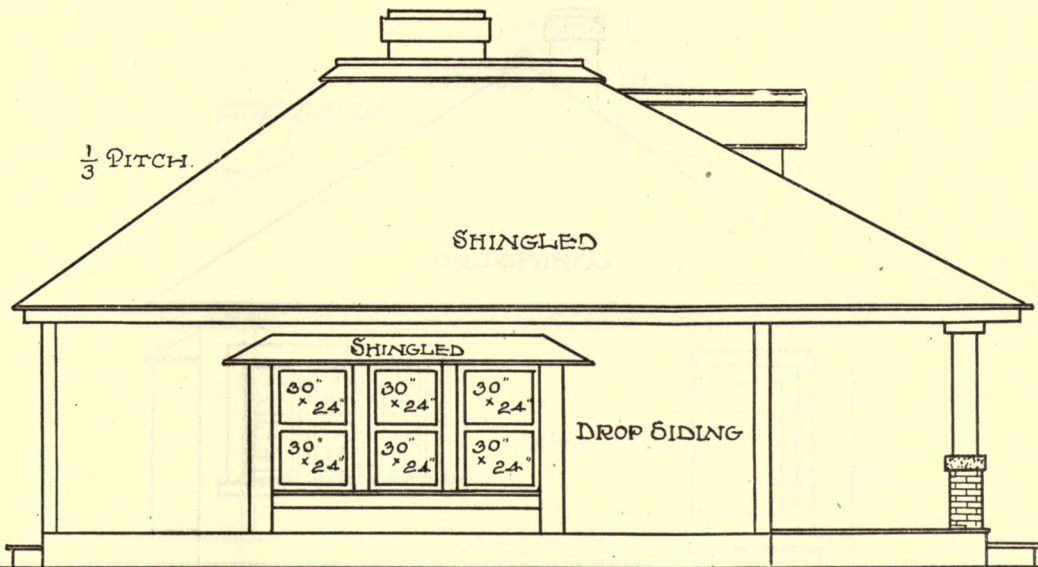

SOUTH ELEVATION
SCALE ~

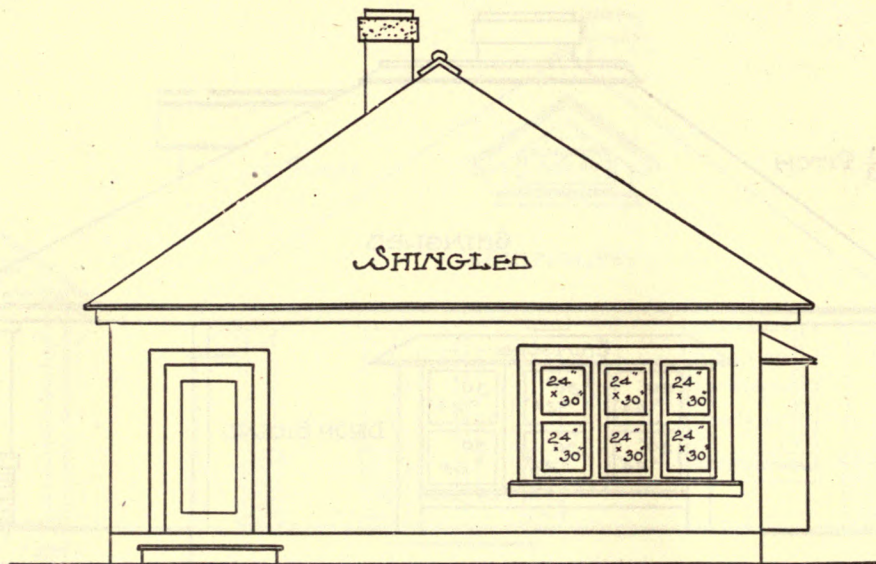

WEST ELEVATION
SCALE ~

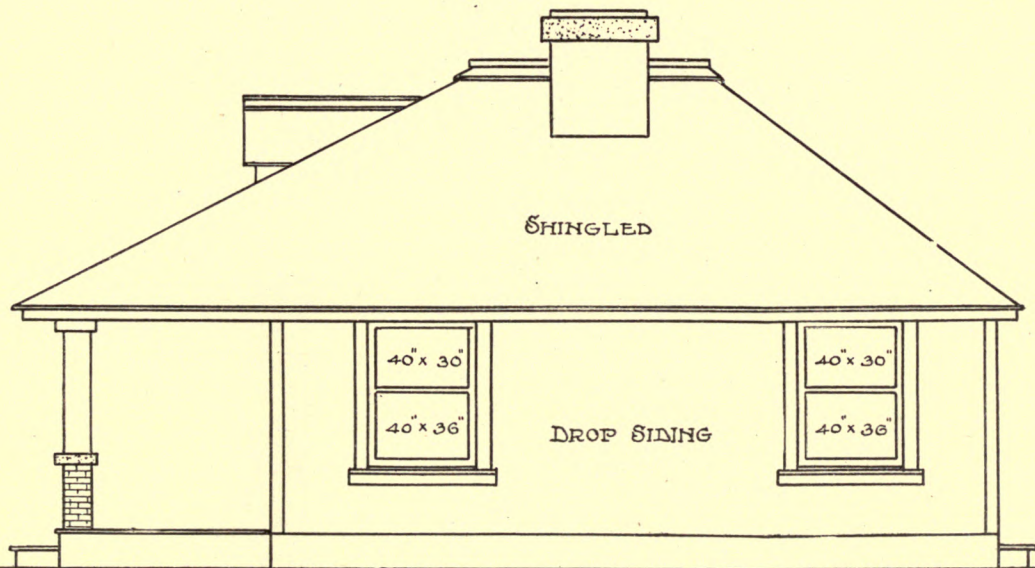

NORTH ELEVATION
SCALE ~

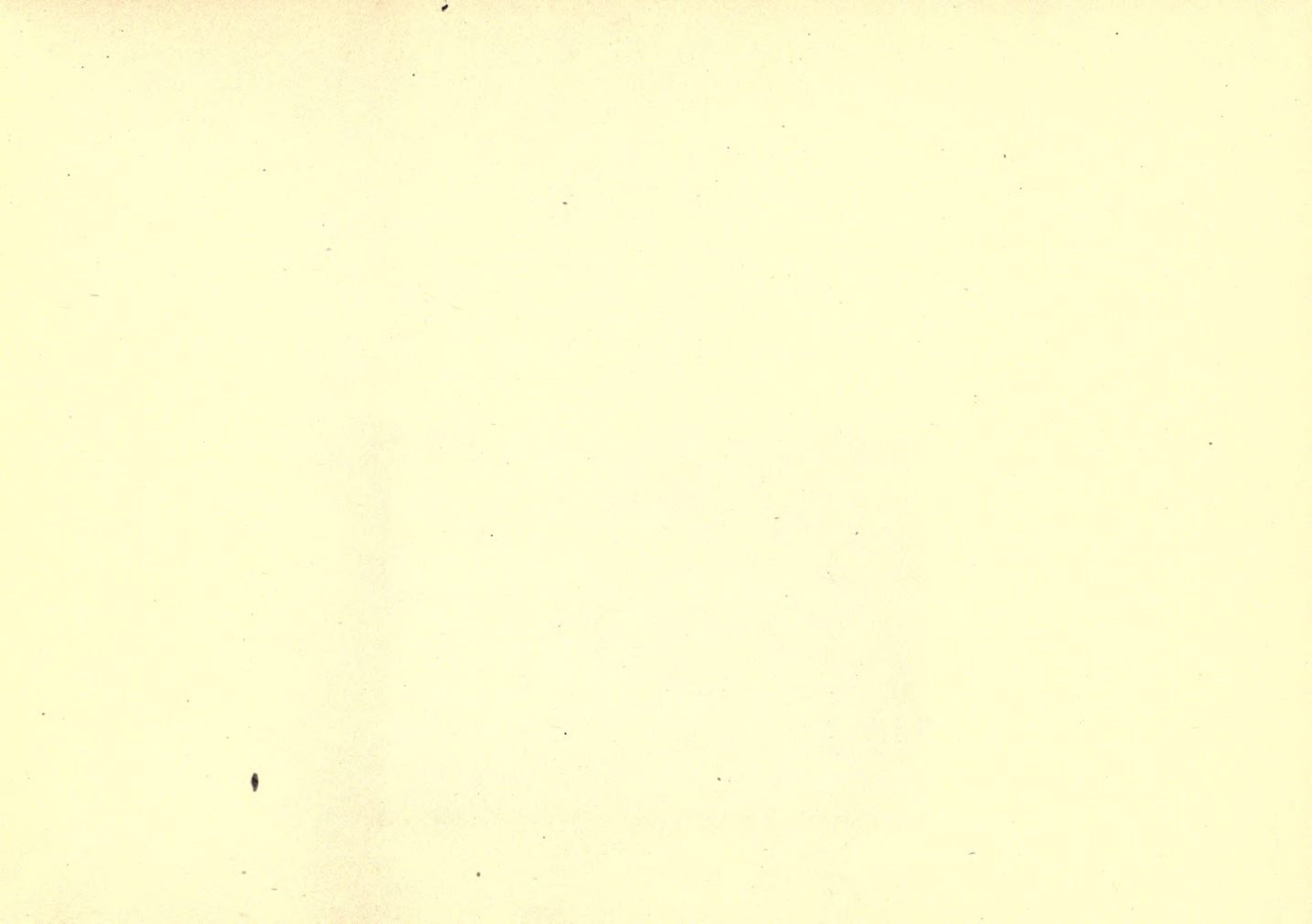



541293

T353

B4

Educ. Dept.

UNIVERSITY OF CALIFORNIA LIBRARY

